



International Journal of Intellectual Advancements and Research in Engineering Computations

Natural frequency analysis of helicopter rotor blades

N Narasimulu¹, Pedomuthevi Vijayanand², Dr.S.Jaya Krishna³

¹PG Student, Department of Mechanical Engineering (CAD/CAM), Holy Mary Institute of Technology and Science, Hyderabad

²Associate Professor, Department of Mechanical Engineering, Holy Mary Institute of Technology and Science, Hyderabad

²Professor, Department of Mechanical Engineering, Holy Mary Institute of Technology and Science, Hyderabad

ABSTRACT

Rotor blades of helicopters have to possess stiffness and strength that keep structural stresses within functional limits. The aerodynamic and structural loads developed by the rotation of blades fluctuate through the rotational cycles. And vibration frequencies effecting on blades including environmental effects consideration, in this project find the structural stresses of blades and vibrational frequencies, this analysing using the ansys software. Analysis using the Kevlar 49, carbon epoxy and advanced composite carbon fiber materials because of this material are light weight and high strength, good resistance materials. Design with the help of catia v5 software.

Keywords: Aerodynamics forces, Helicopter blades, Ansys, Structural analysis, Vibration analysis.

INTRODUCTION

Helicopters are made in different types and shapes depending upon their purposes and required payloads. But most of them share similar parts and components. One of the most important components among these is helicopter rotor or rotor system (fig.1). Its purpose is to generate the lift to carry the weight of helicopter and the payload as well as to provide thrust to act against the drag generated during forward flight. Main components of a rotor system are mast, hub and rotor blades.

Mast is a cylindrical metal shaft which is hollow from inside and is attached to the gearbox. On the top of the mast a hub is present for the attachment of rotor blades. Rotor blades are very important part of rotor system and they attached to the hub by many different ways. Rotor system is divided into 3 different categories: rigid, semi-rigid and fully articulated. These classifications are done on the basis of attachment of rotor blades with hub and their motion with respect to the mast.



Fig. 1: Helicopter rotor system

Author for correspondence:

PG Student, Department of Mechanical Engineering (CAD/CAM), Holy Mary Institute of Technology and Science, Hyderabad

TYPES OF ROTOR SYSTEMS

Rigid

In rigid rotor system there are no hinges present so it is also called hinge less rotor system and

blades are flexibly attached to the hub (fig.2). Drag and flap motion of blade takes place at root about a flexible section. This type rotor system is much simpler than fully articulated rotor system.



Fig. 2: Rigid rotor system

Semi-rigid

In this rotor system there are two blades attached under one teetering or flapping hinge in opposite direction. This results in flapping motion

of blades in opposite direction (fig.3). There is also a feathering hinge at the root for pitching of rotor blades.



Fig 3: Semi-rigid rotor system

Rotor Blade Design

Airfoil, lift and drag

Probably the single most important rotor design parameter is its Lift/Drag ratio, which should be as high as possible.

This ratio depends on the design of the aerofoil, and before we go on to discuss a number of types, we will first introduce the fineness ratio. This is the thickness of the airfoil as a percentage of the chord length. A blade with a good L/D performance has a fineness ratio of about 15%, with its maximum

chamber being a quarter of the way back from the leading edge. A typical L/D value for a helicopter blade is 30:1.

The types of aerofoils used with a rotor blade differ (figure below). For a long time, most of them were symmetrical. However, a higher L/D ratio is possible with non-symmetrical versions. Due to the greater internal forces occurring in these types of blades, they only came into existence when the appropriate composite materials were developed. These can cope with the high internal strain, while their weight is kept low.



Symmetrical aerofoil



Asymmetrical aerofoil

Forces Acting on the Aircraft

Once a helicopter leaves the ground, it is acted upon by four aerodynamic forces; thrust, drag, lift and weight. Understanding how these forces work and knowing how to control them with the use of power and flight controls are essential to flight. They are defined as follows:

- Thrust—the forward force produced by the power plant/propeller or rotor. It opposes or overcomes the force of drag. As a general rule, it acts parallel to the longitudinal axis. However, this is not always the case, as explained later.
- Drag—a rearward, retarding force caused by disruption of airflow by the wing, rotor,

fuselage, and other protruding objects. Drag opposes thrust and acts rearward parallel to the relative wind.

- Weight—the combined load of the aircraft itself, the crew, the fuel, and the cargo or baggage. Weight pulls the aircraft downward because of the force of gravity. It opposes lift and acts vertically downward through the aircraft's center of gravity (CG).
- Lift—opposes the downward force of weight, is produced by the dynamic effect of the air acting on the airfoil, and acts perpendicular to the flight path through the center of lift.

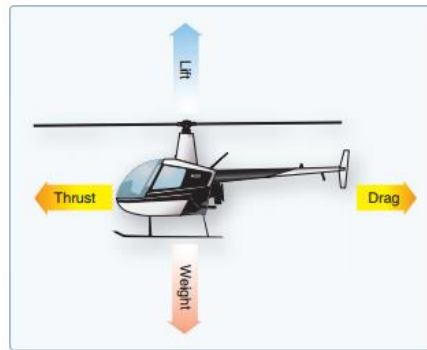

Four forces acting on a helicopter in forward flight.

LITERATURE REVIEW

- The earliest references for vertical flight have come from China. Since around 400 BC, Chinese children have played with bamboo flying toys. The bamboo-copter is spun by rolling a stick attached to a rotor. The spinning creates lift, and the toy flies when released. The 4th-century AD Daoist book Baopuzi by Ge Hong "Master who Embraces Simplicity" reportedly describes some of the ideas inherent to rotary wing aircraft.
- In 1861, the word "helicopter" was coined by Gustave de Ponton d'Amécourt, a French

inventor who demonstrated a small, steam-powered model. While celebrated as an innovative use of a new metal, aluminum, the model never lifted off the ground. D'Amécourt's linguistic contribution would survive to eventually describe the vertical flight he had envisioned. Steam power was popular with other inventors as well.

- In 1906, two French brothers, Jacques and Louis Breguet, began experimenting with airfoils for helicopters. In 1907, those experiments resulted in the Gyroplane No.1.

Although there is some uncertainty about the dates, sometime between 14 August and 29 September 1907, the Gyroplane No. 1 lifted its pilot into the air about two feet (0.6 m) for a minute. The Gyroplane No. 1 proved to be extremely unsteady and required a man at each corner of the airframe to hold it steady. For this reason, the flights of the Gyroplane No. 1 are considered to be the first manned flight of a helicopter, but not a free or un-tethered flight. Tandem rotors are two horizontal main rotor assemblies mounted one behind the other with the rear rotor mounted slightly higher than the front rotor.

- Tandem rotors achieve pitch attitude changes to accelerate and decelerate the helicopter through a process called differential collective pitch. To pitch forward and accelerate, the rear rotor increases collective pitch, raising the tail and the front rotor decreases collective pitch, simultaneously dipping the nose. To pitch

upward while decelerating (or moving rearward), the front rotor increases collective pitch to raise the nose and the rear rotor decreases collective pitch to lower the tail. Yaw control is developed through opposing cyclic pitch in each rotor; to pivot right, the front rotor tilts right and the rear rotor tilts left, and to pivot left, the front rotor tilts left and the rear rotor tilts right.

DESIGN

CATIA offers a solution to shape design, styling, surfacing workflow and visualization to create, modify, and validate complex innovative shapes from industrial design to Class-A surfacing with the ICEM surfacing technologies. CATIA supports multiple stages of product design whether started from scratch or from 2D sketches. CATIA is able to read and produce STEP format files for reverse engineering and surface reuse

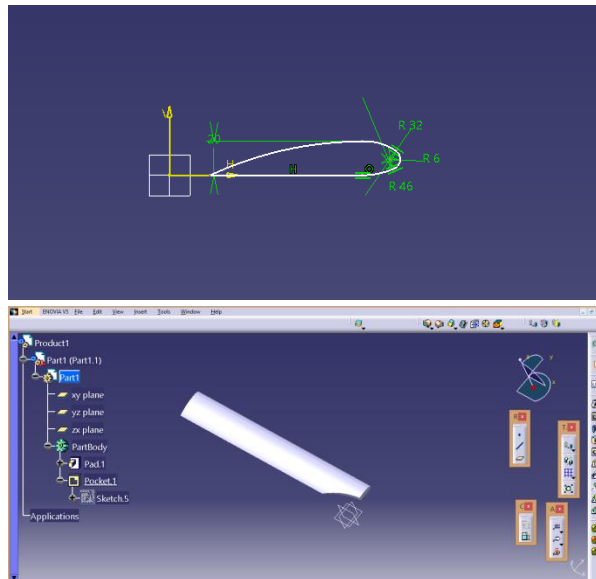

Ansys

- Modal Analysis : Process for determining the N natural frequencies and mode shapes
Given “suitable” initial conditions, the structure will vibrate at one of its natural Frequencies
- The shape of the vibration will be a scalar multiple of a mode shape
- Given “arbitrary” initial conditions, the resulting vibration will be a
- Superposition of mode shapes
- Determines the vibration characteristics (natural frequencies and mode shapes) of a structural components
- Natural frequencies and mode shapes are a starting point for a transient or harmonic analysis

Material data

Carbon Fiber Composite Materials

Density	1.6 kg m⁻³
Coefficient of Thermal Expansion	2.15 C ⁻¹
Thermal Conductivity	78.8 W m ⁻¹ C ⁻¹
Specific Heat	1.13 J kg ⁻¹ C ⁻¹

MESH

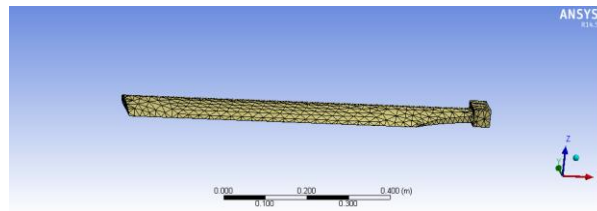

Total Deformation

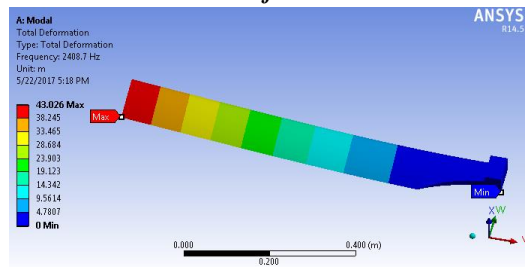

Total Deformation2:

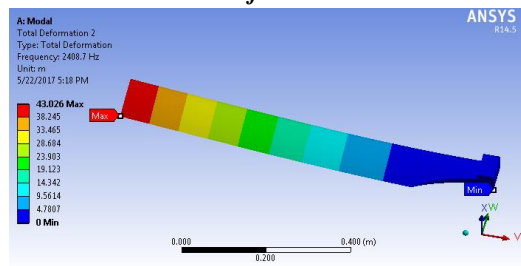

Total Deformation3:

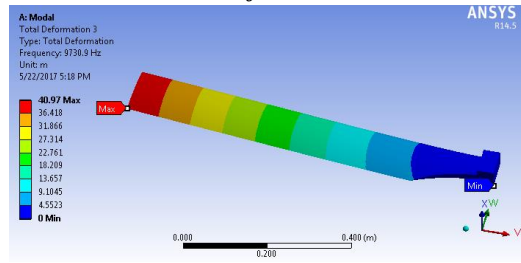

Object Name	Total Deformation	Total Deformation 2	Total Deformation 3	Total Deformation 4	Total Deformation 5
Minimum	0. m				
Maximum	43.026 m		40.97 m	43.523 m	58.946 m
Frequency	2408.7 Hz		9730.9 Hz	15208 Hz	42453 Hz

MATERIALS

kevaler 49

Density 1.45e+005 kg m⁻³

Young's Modulus Pa	Poisson's Ratio	Bulk Modulus Pa	Shear Modulus Pa
1.35e+011	0.36	1.6071e+011	4.9632e+010

Total Deformation

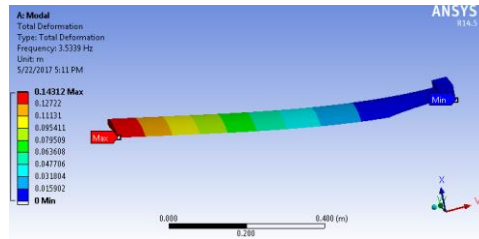

Total Deformation2:

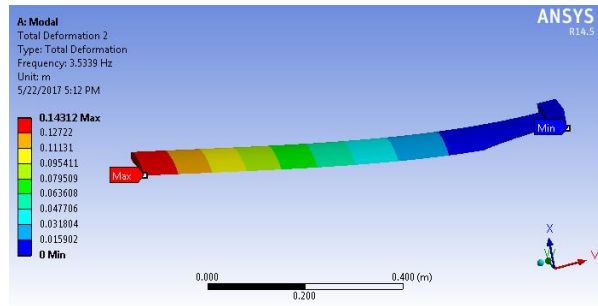

Total Deformation3:

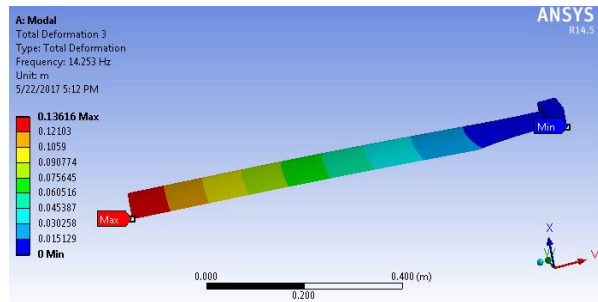

Object Name	Total Deformation	Total Deformation 2	Total Deformation 3	Total Deformation 4	Total Deformation 5
Minimum	0. m				
Maximum	0.14312 m		0.13616 m	0.14495 m	0.27037 m
Frequency	3.5339 Hz		14.253 Hz	22.293 Hz	58.683 Hz

MATERIAL DATA

Carbon epoxy

Density 1800 kg m⁻³

Young's Modulus Pa	Poisson's Ratio	Bulk Modulus Pa	Shear Modulus Pa
4.5e+011	0.3	3.75e+011	1.7308e+011

Total Deformation

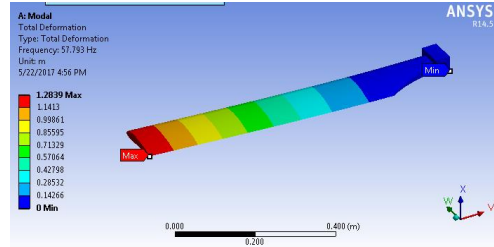

Total Deformation2

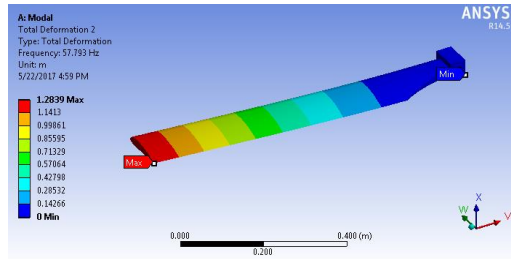

Total Deformation3

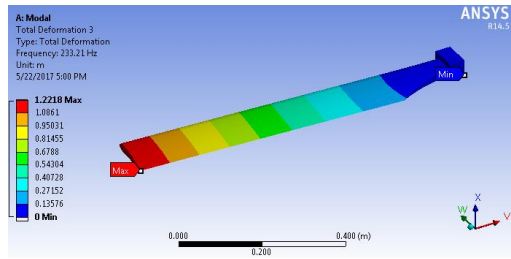

Object Name	Total Deformation	Total Deformation 2	Total Deformation 3	Total Deformation 4	Total Deformation 5
Minimum	0. m				
Maximum	1.2839 m		1.2218 m	1.3 m	2.4994 m
Frequency	57.793 Hz		233.21 Hz	364.65 Hz	981.43 Hz

CONCLUSION

In this paper a helicopter rotor blade was considered to be replaced by a different three materials. Its design procedure is studied and along with catia v5 some important parameters were obtained. The helicopter rotor blade having high modulus and strength Carbon Epoxy, Kevlar 49, Carbon Fibre Composite Materials multi-layered composites has been designed. Modal analysis is conducted to obtain natural frequencies of the helicopter rotor blade. The effect of boundary conditions and the stacking sequence of the composite layers on the strength of the Carbon Epoxy, Kevlar 49, Carbon Fibre Composite Materials rotor blade is studied. We observed that the deflection of the blade and maximum stress obtained can withstand for helicopter blade. The replacement of composite

materials has resulted in a considerable amount of weight reduction when compared to existing materials.

Carbon fiber material is more frequency values and high von Mises value compared to other two materials. Maximum elastic strain and least deformation value is occurring in Carbon epoxy material. Comparing with existing Kevlar 49 material Carbon epoxy and Carbon fiber better results are obtained.

FUTURE SCOPE

Different other composite materials can be used for analysis and for different thickness i.e. for symmetric condition the helicopter rotor blade can be analyzed for further investigation. For further investigation, the rotor blade can be analyzed with model analysis. It is possible to do the regression

analysis for same work. For the same geometry rotor blade is possible.
modal analysis to find the natural frequency of

REFERENCES

- [1]. Leishman, J. Gordon. *Principles of Helicopter Aerodynamics*. Cambridge aerospace series, 18. Cambridge: Cambridge University Press. ISBN 978-0-521-85860-1. 2006, 7-9. Web extract
- [2]. *Taking Flight: Inventing the Aerial Age, from Antiquity Through the First World War*. Oxford University Press. 2003, 22–23. ISBN 978-0-19-516035-2.
- [3]. Joseph Needham, *Science and civilisation in China: Physics and physical technology, mechanical engineering* 4(4), 1965, 583-587.
- [4]. John D. Anderson. *Inventing Flight: The Wright Brothers & Their Predecessors*. JHU Press. 2004, 35. ISBN 978-0-8018-6875-7.
- [5]. Video.
- [6]. Savine, Alexandre. "TsAGI 1-EA." *ctrl-c.liu.se*, 24, 1997. Retrieved 12, 2010.
- [7]. Harris, Franklin D. "Rotor Performance at High Advance Ratio: Theory versus Test" page 119 NASA/CR—2008–215370, 2008.13, 2014.
- [8]. Head, Elan. "A better track and balance". *Vertical Magazine*. 38, 2015. Retrieved 11, 2015.
- [9]. Croucher, Phil. Professional helicopter pilot studies 2-11. ISBN 978-0-9780269-0-5. Quote: [Rotor speed] "is constant in a helicopter".
- [10]. John M. Seddon, Simon Newman. Basic Helicopter Aerodynamics p216, *John Wiley and Sons*, 2011. Accessed: 25, 2012. ISBN 1-119-99410-1. *Quote: The rotor is best served by rotating at a constant rotor speed*
- [11]. Robert Beckhusen. "Army Dumps All-Seeing Chopper Drone" *Wired* 25, 2012. Accessed: 12 2013. Archived on 22, 2015. *Quote: The number of revolutions per minute is also set at a fixed rate*
- [12]. The UH-60 permits 95–101% rotor RPM UH-60 limits *US Army Aviation*. Accessed: 2, 2010