



Effluent Treatment Plant

S.Menakambal¹, Divakaran K², Haripraveen N², Jagatheesh P², Kanthavel S²
Email:menakambal.subramani@nandhaengg.org

¹ Asst. Prof., Department of EEE, Nandha Engineering College, Erode, India

² UG scholar, Department of EEE, Nandha Engineering College, Erode, India

ABSTRACT

All industrial operations produce some wastewaters which must be returned to the environment. Sugar industries produce wastewater, otherwise known as effluent, as a by-product of their production. Effluent from the sugar industry is a major source of environmental pollution, especially water pollution. Among the various stages of sugar production, the operations in the processing plant, which include pre-treatments and finishing, produce the most pollution. The processing wastes contain unused or partially used organic compounds, and high biochemical oxygen demand (BOD) and chemical oxygen demand (COD). The proposed system deals with the monitoring of the water and transmitting the data remotely.

I. INTRODUCTION

Power supply: a group of circuits that convert the standard ac voltage (120 V, 60 Hz) provided by the wall outlet to constant dc voltage
Transformer : a device that step up or step down the ac voltage provided by the wall outlet to a desired amplitude through the action of a magnetic field
Rectifier: a diode circuits that converts the ac input voltage to a pulsating dc voltage [1].

The pulsating dc voltage is only suitable to be used as a battery charger, but not good enough to be used as a dc power supply in a radio, stereo system, computer and so on[2]. In summary, a full-wave rectified signal has less ripple than a half-wave rectified signal and is thus better to apply to a filter.
Filter: a circuit used to reduce the fluctuation in the rectified output voltage or ripple. This provides a steadier dc voltage.
Regulator: a circuit used to produces a constant dc output voltage by reducing the ripple to negligible amount. One part of power supply.

II. ARDUINO MICROCONTROLLER

Arduino microcontroller is an easy to use yet single board computer It has gained considerable traction in the hobby he professional market he arduino is open source Which means hardware is reasonably priced and development software is free.

A. ARDUINO BOARD

Arduino is a single-board microcontroller intended to make the application of interactive objects and environments more easier. Basically this is very user friendly. There is a microcontroller unit embedded on it. The code is directly loaded from the computer. Arduino is a single-board

Microcontroller intended to make the application of interactive objects and environments more easier. Basically this is very user friendly. There is a microcontroller unit embedded on it. The code is directly loaded from the computer.

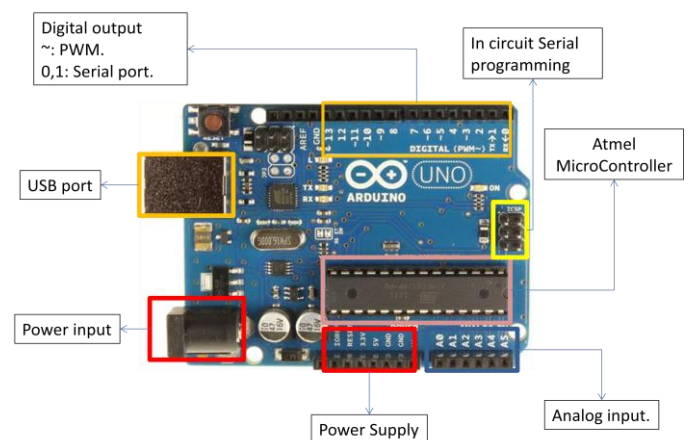

Figure: 1. Arduino Board

B. EXISTING SYSTEM

The current system of ETP monitoring is done with manual readings. The user has to go onsite and test the levels of concentration. The data is transferred to the office either in paper or wired communication. A microcontroller board, contains on-board power supply, USB port to communicate with PC, and an Atmel microcontroller chip. It simplify the process of creating any control system by providing the standard board that

can be programmed and connected to the system without the need to any sophisticated PCB design and implementation. This is an open source hardware, any one can get the details of its design and modify it or make his own one himself.

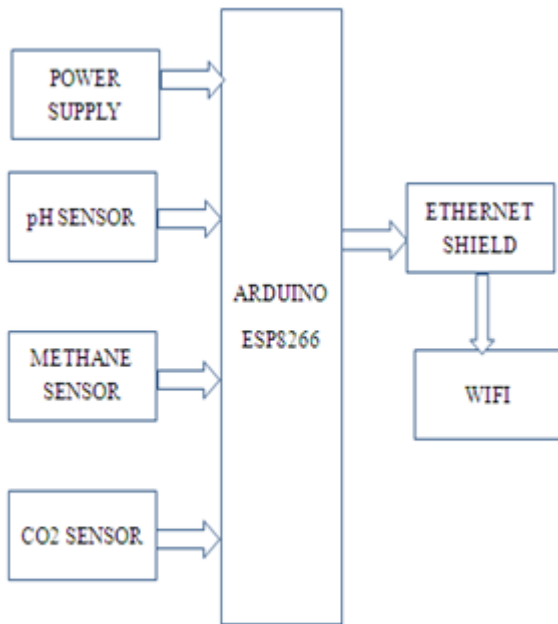

Figure: 2. Block Diagram of ETP

C. POWER SUPPLY

Batteries are often shown on a schematic diagram as the source of DC voltage but usually the actual DC voltage source is a power supply. There are many types of power supply. Most are designed to convert high voltage AC mains electricity to a suitable low voltage supply for electronics circuits and other devices. A more reliable method of obtaining DC power is to transform, rectify, filter and regulate an AC line voltage[3]. A power supply can be broken down into a series of blocks, each of which performs a particular function. This paper deals with the monitoring of effluent treatment plant using sensors. Here the parameters such as the methane, pH, CO₂ are continuously sensed using sensors. The sensors are then fed to the ADC of arduino where the analog to digital conversions take place. The arduino then transmits the data through wifi. To use the shield, mount it on top of an Arduino board (e.g. the Uno). To upload sketches to the board, connect it to your computer with a USB cable as you normally would[4]. Once the sketch has been uploaded, you can disconnect the board from your computer and power it with an external power supply. Connect the shield to your computer or a network hub or router using a standard ethernet cable (CAT5 or CAT6

with RJ45 connectors). Connecting to a computer may require the use of a cross-over cable (although many computers, including all recent Macs can do the cross-over internally).

D. NETWORK SETTINGS

The shield must be assigned a MAC address and a fixed IP address using the Ethernet.begin () function. A MAC address is a globally unique identifier for a particular device. Current Ethernet shields come with a sticker indicating the MAC address you should use with them. For older shields without a dedicated MAC address, inventing a random one should work, but don't use the same one for multiple boards. Valid IP addresses depend on the configuration of your network. It is possible to use DHCP to dynamically assign an IP to the shield. Optionally, you can also specify a network gateway and subnetmask(int pin, long period, int startingValue, int repeatCount) Toggle the state of the digital output 'pin' every 'period' milliseconds 'repeatCount' times. The pin's starting value is specified in 'startingValue', which should be HIGH or LOW. Returns the ID of the timer event. int pulse(int pin, long period, int startingValue) Toggle the state of the digital output 'pin' just once after 'period' milliseconds. The pin's starting value is specified in 'startingValue', which should be HIGH or LOW. Returns the ID of the timer event. int stop(int id) Stop the timer event running. Returns the ID of the timer event. int update() Must be called from 'loop'. This will service all the events

E. TRANSFORMER

Centre tapped transformer. 19-0-19 v at the output. Rating of 1A current. It is centre tapped to have both -ve and +ve half cycle of AC waveform to contribute to direct current. Transforming energy using mutual induction. TTL logic circuitry can not work on voltage of 220v so we are stepping down it to 9v

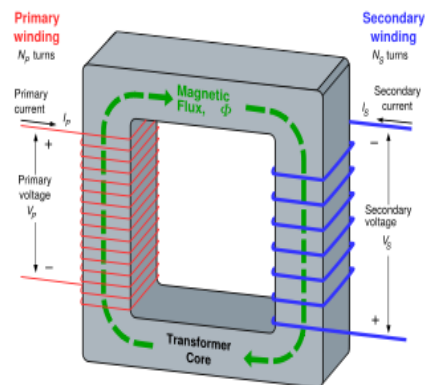

Figure: 3. Center Tapped Transformer

F. LM7805-VOLTAGE REGULATOR

It has 5V Regulated output voltage. Input voltage range:- 5V-18V The voltage source in circuit may have fluctuation and would not give fixed output voltage. Pin1 input, Pin2-ground, Pin3-output Heat sink is used for dissipating heat into surrounding aito protect device from damage.

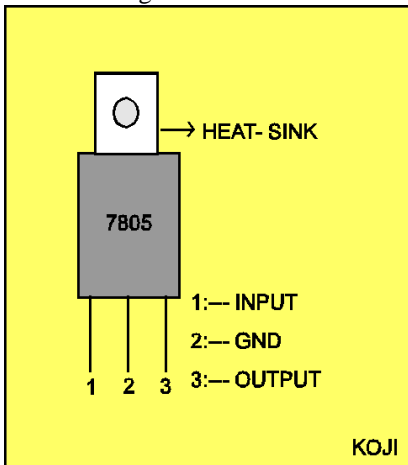

Figure: 4 . Voltage Regulator

G. IC VOLTAGE REGULATORS

Regulation circuits in integrated circuit form are widely used. Their operation is no different but they are treated as a single device with associated components. These are generally three terminal devices that provide a positive or negative output. Some types have variable voltage outputs. A typical 7800 series voltage regulator is used for positive voltages. The 7900 series are negative voltage regulators. These voltage regulators when used with heatsinks can safely produce current values of 1A and greater. he capacitors act as line filtration. Several types of both linear (series and shunt) and switching regulators are available in integrated circuit (IC) form. Single IC regulators contain the circuitry for: Generally, the linear regulators are three-terminal devices that provides either positive or negative output voltages that can be either fixed or adjustable.

H. FIXED VOLTAGE REGULATOR

The fixed voltage regulator has an unregulated dc input voltage V_i applied to one input terminal, a regulated output dc voltage V_o from a second terminal, and the third terminal connected to ground. Fixed-Positive Voltage Regulator The series 78XX regulators are the three-terminal device that provide a fixed positive output voltage.

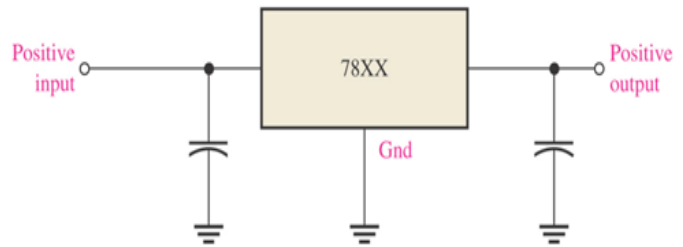

Figure 5: Fixed Voltage Regulator

III. RESULTS AND ANALYSIS

A. Nature of Produced Fertilizer

The CETP sludge used in the research possessed a composition that is suitable for sanitary landfill under the Technical Guidelines on Solid Waste Management in Sri Lanka. However by improving the carbon to nitrogen ratios (by mass) between 25 and 50 which are optimum for aerobic composting, a fertilizer can be produced with similar outcome using the Delta-D technology.

The source sludge analysis is presented in Table I below.

TABLE I SOURCE SLUDGE COMPONENT ANALYSIS

Parameter	Result	LOQ	Unit
Total Nitrogen (N)	3.1	-	% by mass
Phosphorous (P)	6.1	-	% by mass
Potassium (K)	6.9	-	% by mass
Organic Carbon (C)	7.8	-	% by mass
Lead (Pb)	5.9	0.04	mg/kg
Chromium (Cr)	188	-	mg/kg
Mercury (Hg)	ND	0.04	mg/kg
pH	8.1	-	
Faecal Coliform	110	-	MPN/g

The produced fertilizer is of indefinite composition and an ultimate analysis need not be undertaken. The nutrients, micro nutrients and heavy metals of concern were analyzed.

IV. CONCLUSION

Thus the entire Effluent treatment plant is designed and controlled in order to get the effluent treated. The important parameter of the effluent plant is monitored and controlled. Thus the various process are controlled with the help of various control loops. Thus monitoring and controlling the entire plant using IOT helps to reduce human intervention and increases the safety of the plant.

REFERENCES

- [1].M.F.H.M.Aadhil,K.K.D.I.K.Gunaratne,A.M.U.Da nanjina,S.A.S.PereraConversion of sugar Industry Effluent Treatment Plant Sludge Into a Valuable Organic Fertilizer using Delta –D Technology, Vol.7,No.15,July 2017.
- [2] S.Menakambal, G.Ramani, “Advanced RISC Machine Based Data Acquisition Development And Control”, SSRG International Journal of Electrical & Electronics Engineering, Vol 1., Issue 8., Oct ,2014, pp 1-4
- [3] S.Menakambal, A.Satheesh,“Solar Energy Based Optimal Battery Charging Mechanism in Robotic Vehicle by Using Smart Host Microcontroller”, IOSR Journal of Electrical& Electronics Engineering, Vol 4., Issue 4., Jan-Feb,2013,pp
- [4] F. Renault, B. Sancey, P.-M. Badot and G. Crini, “Chito-san for coagulation/flocculation processes— an eco- friendly approach,” Vol. 45, No. 5, 2009, pp. 1337-1348.
- [5]. A. A. Tatsi, A. I. Zouboulis, K. A. Matis and P. Samaras, “Coagulationflocculation pretreatment of sanitary landfill leachates,”Vol. 53, No. 7, 2003, pp. 737-744.
- [6]. I. Khouni, B. Marrot, P. Moulin and R. B. Amar, “De-colourization of the reconstituted textile by different process treatments: enzymatic catalysis, coagulation / flocculation and nanofiltration processes, Vol. 268, 2011, pp. 27-37.
- [7]. Hossam Altaher, Emad ElQada and Waid Omar, “Pretreatment of wastewater streams from petroleum/petrochemical industries using coagulation,” Copyright © 2011 SciRes. ACES.
- [8]. P. N. Johnson and A. Amirtharajah, “Ferric chloride and alum as single and dual coagulants,” Journal of American Water Works Association.
- [9]. M. Rossini, J. Garcia Garrido and M. Galluzzo, “Optimi-zation of the coagulation-floccu