



Digital Relay Protection of Generator Transformer in Thermal Power Station Using Microcontroller

S.Elango ¹, Dhinesh E ², Santhosh kumar K ², Sethupathi S ², Vivek S ²

Email: kskpgp04@gmail.com

¹ Asst. Prof., Department of EEE, Nandha Engineering College, Erode, India

²UG scholar, Department of EEE, Nandha Engineering College, Erode, India

I. ABSTRACT

The main intention of this project is to design a microcontroller based system that can be used in power transformer protection. The system checks the operating parameters of the transformer i.e. current and reports the quantity that is flowing through the transformer. The system is designed such that it is able to detect currents above the normal operating level and isolate the power transformer from the distribution line. This isolation process is to ensure that the transformer is safe from any excess current levels that can make it to overheat thus get damaged. It gives a solution to the need to reduce cost of maintenance and ensure that supply of electricity to consumers is not interrupted for long periods taken while repairing or replacing destroyed transformers.

II. INTRODUCTION

In the design of electrical power transmission and distribution system, there are various factors that need to be considered in the quest to satisfy the needs of electricity consumers. Electrical power systems experience faults at various times due to various reasons. These faults must be foreseen and safety precautions applied to the power system. The power systems engineer must include in his design, safety measures in order to avert any destructive occurrences that the system may undergo at any given time. Power system protection is very essential and necessary for a dependable electrical power supply. It ensures that the system is protected from itself and that the consumer is also safe as he benefits from the electrical power supply. An electrical power system consists of various components such as generators, switches, transmission cables, transformers, capacitor banks among other components. It cannot therefore operate without an effective protective device to keep these components safe and

the system stable. Faults in a power system refer to the undesired conditions that occur in the electrical power system. These conditions may include short circuit, over current, overvoltage, high temperatures among others.

It is clear that over time, there has been an increase in human population, economic growth and technological advancement. This has continuously made the demand for electrical power to go high because as technology, human population and economy grows; there is an increase in demand for power as many more electrical loads are introduced into the supply line. An increase in load leads to a lot of current drawn from the power line. At times the demand goes above what the power distributor can supply. The consequence of this is that electrical power overload cases become common thus posing danger to power system components. This therefore throws in the need for devices that can monitor the rate of power consumption in accordance with the level that a given system is designed to sustain. Such a device must be designed to cut off consumption if the system oversteps its ability thus being dangerous to users and the components. In this project, we look at the protection of power transformer from various faults that may occur and may be destructive to the component if left undetected. The transformer is a very important component in an electrical power system as distribution of electrical power to consumers is more efficiently effected. Every transformer is designed to comfortably supply a given load. Cases of overload or short circuits can lead to transformer being damaged. To combat such occurrence, an elaborate system that monitors these excesses in supply parameters needs to be built. Such a device controls the flow of electrical power to the load so that the transformer is not overworked. Over current relays and overvoltage relays have been used for a long period of time and have been electromechanically controlled. In this system,

a microcontroller is used to monitor cases of electrical faults and communicate to a switch to isolate the transformer from the system.

III. BLOCK DIAGRAM

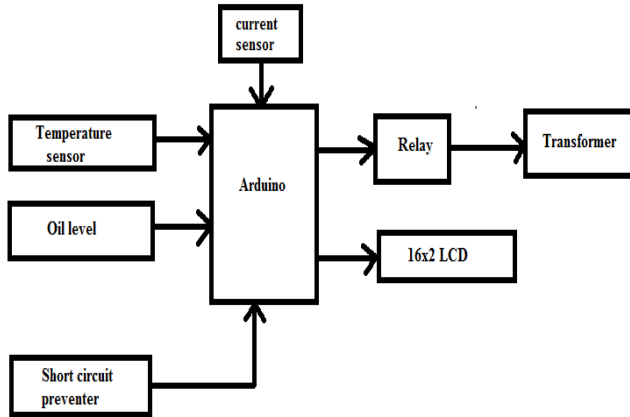

The current, temperature, oil level and voltage are measured by current sensor, temperature sensor, oil level indicator and short circuit preventer respectively. These signals are given as input to the microcontroller. The microcontroller compares these signals with the reference signals. If there are any faults in the measurements, then the microcontroller sends trip signal to the relay. The relay then disconnects the transformer from the generator output.

IV. ARDUINO MICROCONTROLLER

Arduino is a single-board microcontroller to make using electronics in multidisciplinary projects more accessible. The hardware consists of an open-source hardware board designed around an 8-bit Atmel AVR microcontroller, or a 32-bit Atmel ARM. The software consists of a standard programming language compiler and a boot loader that executes on the microcontroller.

An Arduino board consists of an Atmel 8-bit AVR microcontroller with complementary components to facilitate programming and incorporation into other circuits. An important aspect of the Arduino is the standard way that connectors are exposed, allowing the CPU board to be connected to a variety of interchangeable add-on modules known as shields. Some shields communicate with the Arduino board directly over various pins, but many shields are individually addressable via an IC serial bus, allowing many shields to be stacked and used in parallel. Official Arduinos have used the megaAVR series of chips, specifically the

ATmega8, ATmega168, ATmega328, ATmega1280, and ATmega2560. A handful of other processors have been used by Arduino compatibles. Most boards include a 5 volt linear regulator and a 16 MHz crystal oscillator (or ceramic resonator in some variants), although some designs such as the LilyPad run at 8 MHz and dispense with the onboard voltage regulator due to specific form-factor restrictions. An Arduino's microcontroller is also pre-programmed with a boot loader that simplifies uploading of programs to the on-chip flash memory, compared with other devices that typically need an external programmer.

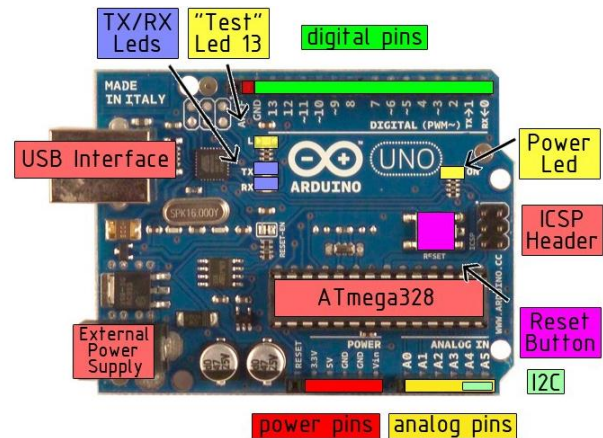

At a conceptual level, when using the Arduino software stack, all boards are programmed over an RS-232 serial connection, but the way this is implemented varies by hardware version. Serial Arduino boards contain a level shifter circuit to convert between RS-232-level and TTL-level signals. Current Arduino boards are programmed via USB, implemented using USB-to-serial adapter chips such as the FTDI FT232. Some variants, such as the Arduino Mini and the unofficial Boarduino, use a detachable USB-to-serial adapter board or cable, Bluetooth or other methods. (When used with traditional microcontroller tools instead of the Arduino IDE, standard AVR ISP programming is used.)

V. CURRENT SENSOR

The Winsen WCS2720 provides economical and precise solution for both DC and AC current sensing in industrial, commercial and communications systems. Typical applications include motor control, load detection and management, over-current fault detection and any intelligent power management system etc... The WCS2720 consists of a precise, low-temperature drift linear hall sensor IC with temperature compensation circuit and a current path with 0.4 mΩ typical internal conductor resistance. This extremely low resistance can effectively reduce power loss, operating

temperature and increase the reliability greatly. Applied current flowing through this conduction path generates a magnetic field which is sensed by the integrated Hall IC and converted into a proportional voltage. The terminals of the conductive path are electrically isolated from the sensor leads. This allow the WCS2720 current sensor to be used in applications requiring electrical isolation without the use of opto-isolators or other costly isolation techniques and make system more competitive in cost.

VI. FLOAT SENSOR

Float Sensor is an electrical ON/OFF Switch, which operates automatically when liquid level goes up or down with respect to specified level. The Signal thus available from the Float Sensor can be utilized for control of a Motor Pump or an allied electrical element like Solenoid, Lamps, and Relays etc. Float Sensors contain hermetical sealed Reed Switch in the stem and a permanent Magnet in the Float. As the Float rises or falls with the level of liquid the Reed Switch is activated by Magnet in the Float.

Hamilton Float Sensors are available in wide range according to operation / material/ mounting methods to suit variety of individual application. These Float sensors are rugged, accurate and reliable in operation.

VII. TEMPERATURE SENSOR

To measure the temperature of the transformer, Thermistor is used. Thermistors are semiconductor devices that are used to measure temperature. The name comes from a combination of the words "resistor" and "thermal". Thermistors have an electrical resistance that is proportional to temperature. There are two types: PTC(Positive Temperature Coefficient of Resistance) and NTC(Negative Temperature Coefficient of Resistance).

NTC thermistors have temperatures that vary inversely with resistance such that as the temperature increases, the resistance decreases, and vice versa.

PTC thermistors are the opposite of NTCs in that they have a resistance that increases with rising temperature and decreases with falling temperature. They are used to protect circuits from overload, and can function as thermal switches or as ordinary thermometers. PTCs are constructed using semiconductors combined with ceramics or polymers.

VIII. RELAY

Relays are electrically controlled switches. In the usual type, a coil pulls in an armature when sufficient coil current flows. Many varieties are available including "latching" and "stepping" relays; the later provided the cornerstone for telephone switching stations, and they're still popular in pinball machines. Relays are available for dc or ac excitation, and coil voltages from 5 volts up to 110 volts are common. "Mercury-wetted" are "reed" relays are intended for high-speed (~ 1ms) applications, and giant relays intended to switch thousands of amps are used by power companies. Many previous relay applications are now handled with Transistor or FET switches, and devices known, as solid-state relays are now available to handle ac switching applications.

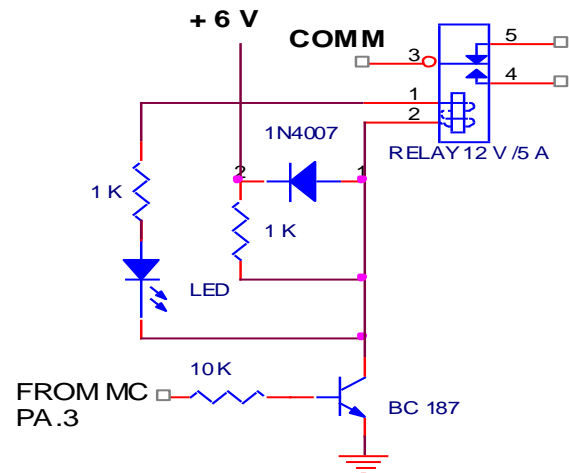

The primary uses of relays are in Remote switching and high-voltage (or high-current) switching. Because it is important to keep electronic circuits electrically isolated from the ac power line, relays are useful to switch ac power while keeping the control signals electrically isolated. The electrical relay offers a simple on / off switching action in response to a control signal. When a current flows through the coil of wire a magnetic field is produced. This pulls a movable arm, the armature, that forces the contacts to open or close; usually there are two sets of contacts with one being opened and the other closed by the action. This perhaps an electric heater in a temperature controls system.

IX. LCD DISPLAY

LCD stands for liquid crystal; this is an output device with a limited viewing angle. The choice of LCD as an output device was because of its cost of use and is better with alphabets when compared with a 7-segment LED display. We have so many kinds of LCD today and our application requires

a LCD with 2 lines and 16 characters per line, this gets data from the microcontroller and displays the same. It has 8 data lines, 3 control line, a supply voltage Vcc (+5v and a GND). This makes the whole device user friendly by showing the balance left in the card. This also shoes the card that is currently being used.

X.CONCLUSION

In this project generator side transformer protection using arduino microcontroller is proposed. For transformer voltage, current, oil level and temperature sensing circuits were designed and the results have been verified. Hardware with arduino microcontroller was implemented to verify the proposed system and the performance of the real time hardware was tested.

The results indicate that the microcontroller based transformer protection achieves numerous advantages over the existing systems in use

- 1) Fast response
- 2) Better isolation
- 3) Accurate detection of the fault.

XI. REFERANCE

- generating-transmitting-and-distributing-electricity. <http://technology.ezinemark.com/generating-transmitting-and-distributing-electricity-7d30ca53b6b0.html>.
- El-Hawary, M. E. Electrical Power Systems: Design and Analysis. s.l. : John Wiley & Sons, 1995.
- Yeshwant G. Paithankar, S. R. Bhide. Fundamentals of Power System Protection. s.l. : 2010, 2010. 3.
- PAC World Magazine. Sachdev, Mohindar S. Redundancy considerations for protective relay systems, 2010.
- Badri Ram, D. M Vishwakarma. Power System Protection and Switchgear. s.l. : Tata McGraw-Hill Education,, 2001.
- Xiangning Lin, Jing Ma, Qing Tian, Hanli Weng. Electromagnetic Transient Analysis and Novell Protective Relaying Techniques for Power Transformers. s.l. : John Wiley and Sons, 2015.
- Harlow, James H. Electric Power Transformer Engineering, Third Edition.
- Greenwald, Peter Ed. Electrical Hazards and Accidents: Their Cause and Prevention. s.l. : John Wiley and Sons, 1990.
- <http://www.electrical4u.com/transformer-protection/>
- https://en.m.wikipedia.org/wiki/mettur_thermal_power_station
- <http://new.abb.com/products/transformers/power/generator-step-up>
- <https://www.arduino.cc/>
- <https://www.arduino.cc/en/Guide/Introduction>
- <https://learn.spark.com/tutorials/>