



Portable solar lighting system

C.Pratheeba¹, K.Karthick², K.S.Rajesh Kumar³, K.Rajkumar⁴, S.Vivek⁵

Professor¹, Department of Electrical and Electronics Engineering, Nandha Engineering College, Erode, Tamil nadu, India

UG Student^{2,3,4,5}, Department of Electrical and Electronics Engineering, Nandha Engineering College, Erode, Tamil nadu, India

pratheebachenniappan@gmail.com

ABSTRACT

Current Solar Electric Vehicles have flat roofs, in an attempt to reduce irradiance mismatches within the strings of PV cells. As a result the aerodynamic performance and design freedom of such vehicles are limited. This paper presents a distributed maximum power point tracking methodology specifically aimed at Solar Electric Vehicles to overcome. As a starting point, the PV-to-isolated bus architecture is selected, since it processes a low amount of power and easily extends to an arbitrary number of groups per string. The collected electricity stored in a battery and used whenever need.

INTRODUCTION

PV array consisting of multiple strings of around 120 series connected PV cells. Can't we use solar power at the night? This question may look somewhat absurd since there is obviously no meaning of "Using solar power

at night"! Now-a-days we are using the solar power to generate electricity by the solar panels mounted on the vehicle.

No clouds block the solar rays, and there is no nighttime. Solar collectors mounted on an orbiting satellite would thus generate power 24 hours per day, 365 days per year. If this power could be relayed to earth, then the world's energy problems might be solved forever. We propose a new method for power generation

A new control strategy for this architecture is introduced, that allows for local, decoupled, true maximum power point tracking. The architecture requires isolated, bidirectional, load independent converters, which were realized by means of a series connected synchronous boost converter.

The outcome of the solar tracker system has analyzed and compared with the fixed or static solar panel found better performance in terms of voltage, current and power. Therefore, the solar tracker is proved more practical for capturing the maximum

sunlight supply for star harvesting applications.

SOLAR TRACKER

A solar tracker is a perfect tool for track the path of the sun from east and west during daytime. For a conscientious line of longitude, every day sun moves from east to west on a fixed solar path. However, the sun moves through 460 degrees north and south throughout the seasonal revision. In our proposed model we have partiality to use micro controller based solar lighting system.

The solar elevation approach is distinct for the reason that the angle located stuck between the horizontal and as a result the line linking to the sun. At nightfall or break of day distance from the ground approach is 0° and formerly the sun is at the pinnacle the height above sea level angle relics 90° . "Fig. 1," shows the position of the sun over the year.

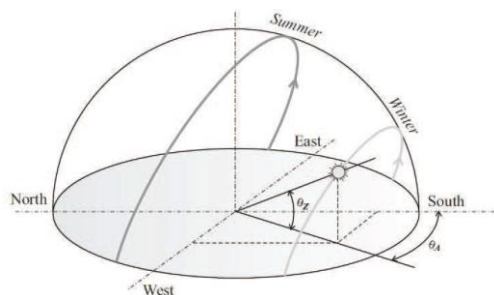

Fig. 1. The different position of the sun over the year

EXPERIMENTAL SETUP

The proposed tracking system can track a lot of daylight in actual fact by PV panel rotation in different axis. we can achieve more energy from the solar panel. During this

emerge, we are able to incarcerate additional sun rays.

The portable solar lighting service is as good as to fixed panel however it captures the solar energy more productively by rotating within the horizontal as well because the vertical axis the likely anticipated for dual axis tracker is shown in "Fig 2," voltage & current sensors, 2 servo motors and Arduino microcontroller

consists our proposed system. One rest of sensors and one motor is used to incline the tracker in sun's east – west route and the other rest of sensors and also the other motor that is mounted at the base of the tracker is used to tilt the tracker within the sun's north-south route.



Proposed Model

The servo motor is performing operate to following the path of the sun. This two servo motor and two sensors are interfaced with a microcontroller that's scheming servo motor on the base of sensor's input. Sun light sense by sensors and send a signal to Arduino microcontroller. The microcontroller received signals from voltage & current sensors and its deciding rotation direction of servo motors.

Portable Solar Lighting system explained with the help of block diagram shown in "Fig. 3,"

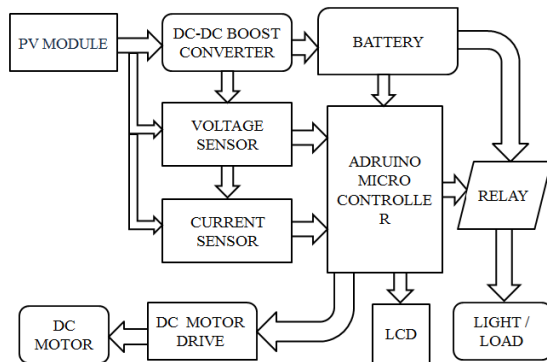

The block diagram is showing that LDR sensors once sensing the sunshine forward the signal to Microcontroller. The microcontroller is a logical device that's enchanting dealings on the root of sensor put in and starting the motor driver's track consequently.

Assume if the sun changes its individual locality and go from east to west, it'll cause light absorption to vary on one sensor as related to different one. On the base of light intensity feature on sensors, the controller starts driver circuits and moves servo motor to new positions wherever light falling on sensor pairs is same.

CIRCUIT DIAGRAM:

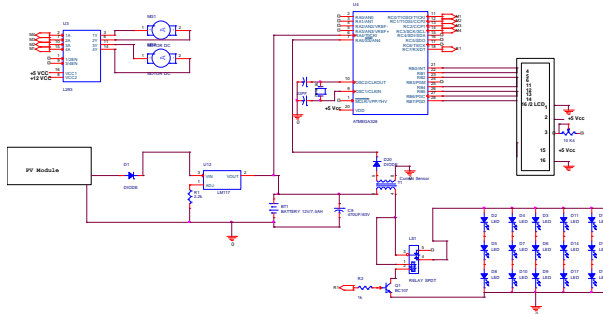

Components

- Power supply
 - ARDUINO UNO
- ### Microcontroller
- Relay Circuit
 - DC-Motor

A) Power supply:

The Available power source is an Ac voltage arrives at 230V. Since our electronic circuits require only very minimal voltage and current we use step down power transformer. Step down transformer is designed in such a way that the input is 230V and output of 12V. Another thing is that electronic circuits operate in DC where as available output of transformer is Ac of 12V. So rectifier circuit is used to convert AC to DC. Rectifier circuit consists of four diodes formed in bridge fashion so as to convert incoming AC to DC.

B) ARDUINO UNO Microcontroller:

The Arduino Uno is a microcontroller board based on the ATmega328 (datasheet). It has 14 digital input/output pins (of which 6 can be used as PWM outputs), 6 analog inputs, a 16 MHz crystal oscillator, a USB connection, a power jack, an ICSP header, and a reset button. It contains everything needed to support the microcontroller; simply connect it to a computer with a USB cable or power it with a AC-to-DC adapter or battery to get started. The Uno differs from all preceding boards in that it does not use the FTDI USB-to-serial driver chip. Instead, it features the Atmega8U2 programmed as a USB-to-serial converter. "Uno" means one in Italian and is

named to mark the upcoming release of Arduino 1.0. The Uno and version 1.0 will be the reference versions of Arduino, moving forward. The Uno is the latest in a series of USB Arduino boards.

C) Relay Circuit:

Relays are electrically controlled switches. In the usual type, a coil pulls in an armature when sufficient coil current flows. Many varieties are available including “latching” and “stepping” relays; the later provided the cornerstone for telephone switching stations, and they’re still popular in pinball machines. Relays are available for dc or ac excitation, and coil voltages from 5 volts up to 110 volts are common. “Mercury-wetted” are “reed” relays are intended for high-speed (~ 1ms) applications, and giant relays intended to switch thousands of amps are used by power companies. Many previous relay applications are now handled with Transistor or FET switches, and devices known, as solid-state relays are now available to handle ac switching applications. The primary uses of relays are in Remote switching and high-voltage (or high-current) switching. Because it is important to keep electronic circuits electrically isolated from the ac power line, relays are useful to switch ac power while keeping the control signals electrically isolated. The electrical relay offers a simple on / off switching action in response to a control signal. When a current flows through the coil of wire a magnetic field is produced. This pulls a movable arm, the armature, that forces the contacts to open are

close; usually there are two sets of contacts with one being opened and the other closed by the action. This perhaps an electric heater in a temperature controls system.

D) DC-Motor:

A electric motor, operation is based on simple electromagnetism. A current-carrying conductor generates a magnetic field; when this is then placed in an external magnetic field, it will experience a force proportional to the current in the conductor, and to the strength of the external magnetic field. As you are well aware of from playing with magnets as a kid, opposite (North and South) polarities attract, while like polarities (North and North, South and South) repel. The internal configuration of a DC motor is designed to harness the magnetic interaction between a current-carrying conductor and an external magnetic field to generate rotational motion.

CONTROL ALGORITHM:

The same method can maintain it up with a change in sun’s locality surrounded by the sky. As a result, this proposed model is able to capture supplementary sun rays and system’s solar energy conversion capability is greatly superior. How control algorithm is performing gesture assessment and is that the key deciding constituent which shows it in “Fig. 5,” When it collects data from LDR sensors then main algorithm is starts. Sensors productivity is analogue that’s stimulated to digital signals.

This serviceable task is performed using analogue to digital converter (ADC). Digitized signals are forwarded to Arduino microcontroller. After collecting digital signals, it decides relating to the movement direction and steep angle of servo motors. Control algorithm is viewing that Arduino microcontroller drives servo motors as long as sensor light sensing is not equal to one another and if sensor signals are equal. It goes to start of the algorithm. This methodology is incessant till light falling on detector pairs is equal and PV panel is adjusted in a position for optimum power.

The voltage generated by the solar panel is assorted and desires to be synchronized. A regulator is often used when the solar panel which may regulate the voltage coming back from solar panel. For this principle, supply is provided by generated solar energy.

There is not any would like to give exterior power supply that makes our system economical and cost effective too. The purposed model can also use as an impartial system by introducing battery storage and proper supervision of storage system. Battery storage is controlled by the thought of generated voltage. Charging and discharging events for storage are electing the idea of generated voltage.

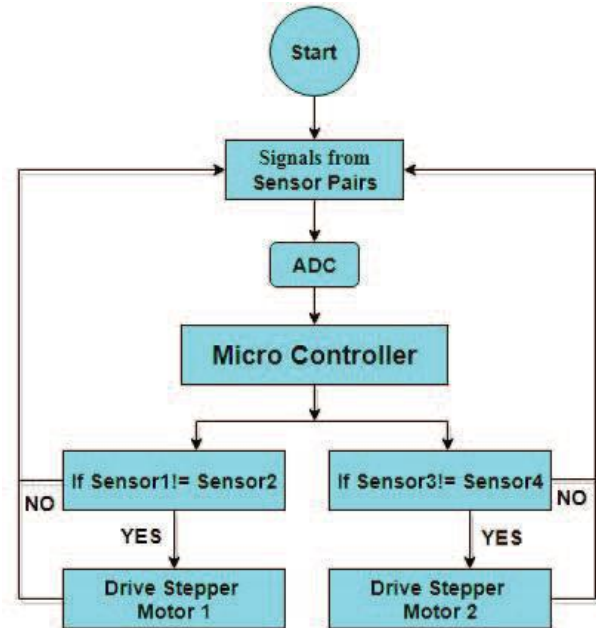

Control Algorithm

HARDWARE IMPLEMENTATION

In all earlier section details of control formula and block diagram of proposed portable solar lighting were represented. Currently, we tend to return to the hardware implementation of the planned model. We have implemented the planned system a lot of and final hardware model is shown in below fig. For sustaining of the hardware we tend to devise a support model that is also shown. This support model is of 2 feet height. For higher control of tracker altitude of the panel is increased and it should be placed in open air atmosphere.

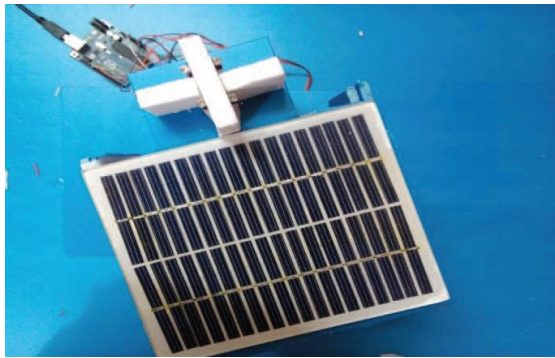

PV Panel

PV panel used for hardware accomplishment is 36-watts and it's of mono crystalline type. Two servo motors of static magnet types are used. Servo motor moves in steps and is best suited for correct position control. PIC microcontroller is used for controlling purpose that is less complicated to use as compared to microcontroller ATMEL family. Details of PV Panel ratings, LDR sensors and servo motor ratings for our hardware design are enlisted in Table I.

TABLE I. COMPONENT RATINGS

Component Name	Component Ratings
PV Panel Dimension	16×16 inches square
PV Panel Rating	35 Watts
PV Panel Material	Mono crystalline
Servo Motor	5v, 0.6 A, 9gr Servo HXT900
Controller	Arduino Uno

Component Ratings

CHARGE CONTROLLER

A charge controller, or charge regulator is fundamentally a voltage and current regulator to stay batteries from

overcharging. It regulates the voltage and current from the solar panels reaching to the battery. It prevents overcharging and will shield against overvoltage, which might scale back battery performance or period of time, and will create a safety risk. It is going to additionally prevent fully draining ("deep discharging") a battery, or perform controlled discharges, counting on the battery technology, to guard battery life.

The charge controller is located in between the output of the solar battery and therefore the input of the battery holder. Once the intensity of daylight is high then solar battery produces more electricity, and once daylight is a smaller amount then produces less electricity. The charge controller is used to calming the variation in electrical input to the battery. It furthermore prevents over charging of the battery thereby increasing its life. A superfluous function of the charge controller is to stop reverse current flow, predominantly during night times.

CONCLUSIONS

Portable Solar Lighting System utterly aligns with the sun route and tracks the sun movement in a very a lot of cost-effective loom and includes a marvelous performance upgrading. The investigational outcomes clearly show that portable solar tracking is good enough than fixed solar systems. The proposed system is value effective conjointly as a stroke adjustment in solar tracker provided notable power increase within the system. Through our experiments, we've got found that dual axis tracking will increase

energy by about 40% of the fixed arrays. With a lot of works and higher systems, we tend to believe that this figure can raise more.

REFERENCES

- [1] Bank, Grameen. "Grameenhakti: pioneering and expanding greenenergy revolution to rural Bangladesh." (2007).
- [2] Afrin, Farhana, TwishaTitirsha, SyedaSanjidah, A. R. M. Siddique, and AsifRabbani. "Installing dual axis solar tracker on rooftop to meet the soaring demand of energy for developing countries." In IndiaConference (INDICON), 2013 Annual IEEE, pp. 1 -5.IEEE, 2013.
- [3] "Journal on: Technical appraisal of solar home systems in Bangladesh: A field investigation Shahriar Ahmed ChowdhuryRenewavle energy", vol. 36, no. 2, pp. 77, feb 2011.
- [4] F. Muhammad-Sukki, S. H. Abu-Bakar, R. Ramirez-Iniguez, S. G. McMeekin, B. G. Stewart, N. Sarmah, T. K. Mallick, A. B. Munir, S.H. Mohd, R. Abdul Rahim, "Mirror symmetrical dielectric totally internally reflecting concentrator for building integrated photovoltaic systems", *Appl. Energy*, vol. 113, pp. 32-40, 2013.
- [5] D. De Boer, "Luminescent solar concentrators: the road to low-cost energy from the sun", *SPIE Newsroom*, pp. 10-12, 2010.