



---

**International Journal of Intellectual Advancements  
and Research in Engineering Computations**

---

**Multilevel Inverter Topology for Renewable Energy Grid  
Integration**

Prabu.M<sup>1</sup>, Deepika.L<sup>2</sup>, Kaviya.S<sup>2</sup>, Palkumarathi.S<sup>2</sup>, Sindhu.P<sup>2</sup>

Email: prabuece2013@gmail.com

ldeepika.erode@gmail.com

kaviya34@gmail.com

palkumarathi@gmail.com

sindhurithanya@gmail.com

<sup>1</sup> Asst. Prof., Department of EEE, Nandha Engineering College, Erode, India

<sup>2</sup> UG scholars, Department of EEE, Nandha Engineering College, Erode, India

**LABSTRACT**

In this paper, We use solar panel as photo voltaic because it converts heat energy to electrical energy as large amount.It is not only used for home appliance but it can also connected with grid.Mainly the power can also generated by renewable energy resources.

**II. INTRODUCTION**

CURRENTLY, there are over 300 GW of wind power generation and over 110 GW photovoltaic generation installed worldwide. Renewable power plants of more than 10 MW in capacity become a reality. However, the renewable

energy sources have highly variable daily and seasonal patterns, and consumer power demand requirements are also extremely variable in nature . Therefore, it is difficult to operate a stand-alone power system supplied from only one type of renewable energy source unless appropriate energy storage facilities. If enough energy storage capacity is not available, especially in medium to large-scale systems, a grid-connected renewable power generation may be the only practical solution

For grid integration, the use of simple conventional inverter, two level, produces a square wave which is not suitable for most of the

intricate applications. In such cases, a pure sinu-soidal wave is desired. Even more, the traditional converters rating power are limited to the rated power of the used semi-conductor devices and the allowed switching frequencies [4]. Conventional inverters based on power-frequency transformers operating at 50 or 60 Hz and AC filters are generally used in renewable power generation systems to step up the voltage to the grid voltage levels of 6–36 kV and to reduce the voltage THD respectively. High investment and installation costs are required because of its heavy weight and large size. With the arrival of new high-power semiconductor devices, new power converter structures are designed to meet the needs of future medium or high-voltage converter systems. In this highly active area, the modular multilevel cascaded (MMC) converter topologies and circuits have attracted a high degree of attention for their application in medium and high-voltage systems. The component numbers of MMC converters grow up linearly with the number of levels, individual modules are identical and modular in construction thereby enabling the attainability of a high level number. However, the MMC converter requires balanced multiple-isolated dc sources. Accordingly, its application is not straightforward, especially in renewable power generation systems. This work

presents a novel three-phase parallel grid connected multilevel inverter topology with  $(2n^2)$  levels in the line output voltage waveform, to feed microgrid with  $n$  renewable energy sources with an optimized THD. The proposed inverter consists of a parallel connection of  $n$  two-level  $(n + 1)$  phase inverters. Each stage of classic inverter is fed from a renewable energy source, for PV array through a DC–DC converter and for wind power through a AC–DC converter. A six level inverter application has been built in this work, the topology needs six legs (2 cascaded power switches per leg) fed by two renewable energy sources (i.e: wind energy and PV energy) and controlled by a pulse width and height modulation technique. This approach reduce significantly the number of required power switches and the switching frequency as compared to the classical topologies. Moreover, the proposed topology shows similarities with the Cascaded H-bridge (CHB) topology in two ways: 1) It needs multiple isolated input dc voltages; and input dc voltage levels can be combined into all additive values. The proposed topology and the related analysis along with simulation and experimental verification is the main contribution of this work.

### III. BLOCK DIAGRAM

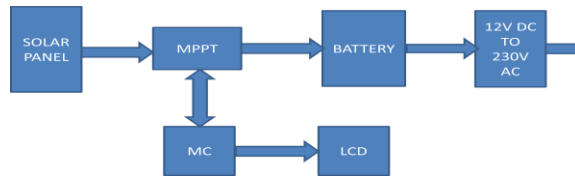
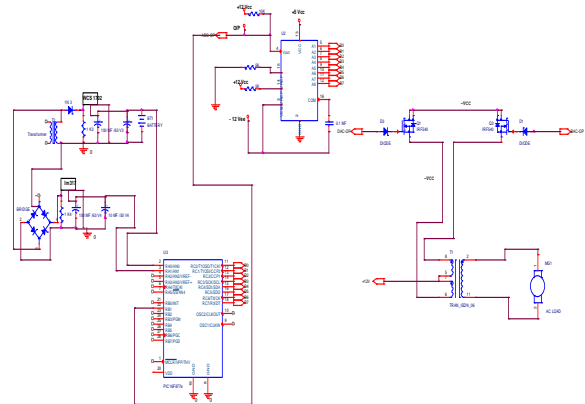

Fig.1: Block diagram

- Solar energy from solar panel and wind energy from wind generator is measured by using MPPT .
- The output energy from MPPT is transferred to battery.
- The ratings of MPPT is calculated by using the controller and displayed in LCD.
- The storage energy in battery can be transferred to 12v DC to 230v AC inverter.
- Then the energy is transferred to load or grid.

### IV.CIRCUIT DIAGRAM



- Solar panel comprises small units called photovoltaic cells contains allowing photons , or particles of light and generating a flow of electricity.
- Isolation transformer contains primary and secondary and its specified to high voltage between windings.
- Inverter converts 12v DC to 230V AC
- It blocks transmission of the Dc component in signal from one circuit to other, but allow AC components in signal to pass.
- Thyristor is a special type of diode that allows current to flow when a control voltage is applied to its gate terminal.

### V.CONCLUSION

The proposed multilevel inverter topology can be a good solution to feed microgrid from renewable energy sources. A six-level inverter was considered and controlled

by using a PWHM technique, requiring only twelve switching states per period. Simulation studies have been performed on a six-level inverter based on the proposed structure and have been validated experimentally. The obtained simulation and experimental results have shown a 15 % voltage THD rate, zeroed successive harmonics from 2<sup>th</sup> to 10<sup>th</sup> orders. The first non-canceled harmonic is 11<sup>th</sup> order with 9 % of the fundamental magnitude. The proposed configuration gives a compact and low cost system with both minimum number of switches and less number of switching states with a simplified inverter control scheme. The efficiency, performance and compliance with IEEE519 1992 and IEC61000 3 12 standards have been validated. The low-frequency switching reduces the inverter power losses leading to a better efficiency of the proposed topology. Comparisons of the proposed topology with conventional topologies reveals that the proposed topology significantly reduces the number of power switches and associated gate driver circuits. Analytical comparisons on the basis of losses indicate that the proposed topology is highly competitive. On the horizon, the detailed real and reactive power control of the proposed inverter will be considered.

## VI. REFERENCES

- 1) R. Islam, Y. Guo, and J. Zhu, "A High-Frequency Link Multilevel Cascaded Medium-Voltage Converter for Direct Grid Integration of Renewable Energy Systems," *IEEE Trans. Power Electron.*, vol. 29, no. 8, pp. 4167-4182, Aug. 2014.
- 2) Manojkumar, K. Porkumaran, and C. Kathirvel, "Power electronics interface for hybrid renewable energy system — A survey," in *Proc. Int. Conf. Green Computing Communication and Electrical Engineering*, Coimbatore, India, pp. 1-9, Mar. 2014.
- 3) Adefarati, and R. C. Bansal, "Integration of renewable distributed generators into the distribution system: a review," *IET Renew. Power Gener.*, vol. 10, no. 7, pp. 873-884, Jul. 2016.
- 4) Dasgupta, S. N. Mohan, S. K. Sahoo, and S. K. Panda, "Application of Four-Switch-Based Three-Phase Grid-Connected Inverter to Connect Renewable Energy Source to a Generalized Unbalanced Microgrid System," *IEEE Trans. Ind. Electron.*, vol. 60, no. 3, pp. 1204-1215, Mar. 2013.
- 5) Solas, G. Abad, J. A. Barrena, S. Aurtenetxea, A. Cárcar and, L. Zajac, "Modular Multilevel Converter With Different Submodule Concepts—Part I: Capacitor Voltage Balancing Method," *IEEE Trans. Ind. Electron.*, vol. 60, no. 10, pp. 4525-4535, Oct. 2013.
- 6) P. Vignesh, T. Jayakumar, "DSP Based Wireless Reflectance Pulse Oximeter for Photoplethysmograms" *International Journal of Science and*

- Research (IJSR), vol. 3 Issue 11, November 2014, pp.534 – 537.
- 7) T. Jayakumar, “Automation on PLC Furnace System Using Labview” International Journal of Electronics & Communication Technology, IJECT Vol. 4, Issue 1, Jan - March 2013, pp. 317 – 320.
  - 8) P. Vignesh, T. Jayakumar, “Implementation Of An Automatic Defibrillator For Cardiac Patients” International Journal of Advanced and Innovative Research (2278-7844) / # 206 / Volume 4 Issue 2, pp. 206 – 209.
  - 9) Karthic P.T, T.Jayakumar , K.Tamilselvan, “ Feature Extraction For Human Identification using Finger And Palm Images” International Journal Of Technology & Engineering Research (IJOTER) Volume (4), Issue (1), January - June- 2016 (e) 0980-9589 (p) 0980-9589x
  - 10) K.Tamilselvan, R.Krishnaraj, P.Sukumar, T.Jayakumar, “Security Method for Human Finger and Palm Images Identification” International Journal of Emerging Technologies in Engineering Research (IJETER) Volume 4, Issue 6, June (2016) pp. 77 -80
  - 11) T.Jayakumar, P.Uvaraj, P.Krishnagandhi, “A Review of Multilevel Selective Harmonic Elimination Techniques” International Journal of Emerging Technologies in Engineering Research (IJETER) Volume 4, Issue 7, July (2016) pp.55-57
  - 12) T.Jayakumar, B.Ramraj, V.Arunkumar “Adaptive Learning and Control of Steam Turbine Brushless Excitation System Using Neuro Fuzzy” International Journal of Emerging Technologies in Engineering Research (IJETER) Volume 4, Issue 7, July (2016) pp.58-67
  - 13) T.Jayakumar, M.Prabu, .Tamilselvan “Analysis of Non-Invasive Pulse Oximetry with Single Light Source Using Fourier series And Soft Computing Techniques” International Journal of Emerging Technologies in Engineering Research (IJETER) Volume 4, Issue 7, July (2016) pp.68-72