



Automatic Broke Feeding System for the Finishing House Pulper in Paper Machine

V. Ravichandran ¹, Aravinth S.A.S ², Dinesh M ², Midhun Johny ², Mohanasundaram K.S ²

Email: vravieec@gmail.com

¹ Asst. Prof., Department of EEE, Nandha Engineering College, Erode, India

² UG scholar, Department of EEE, Nandha Engineering College, Erode, India

I. ABSTRACT

Paper mills produce large quantities of paper daily. In overall production per day, almost 10% of papers are rejected considering quality standards or other reasons. These rejected papers are called as Broke. This rejection takes place at each and every level of the production unit. The final rejection is in the finishing house where all the broke are collected together and fed into pulper as a process of recycling it. This particular pulper machine is a manual sequence process. It involves manual paper loading, valve operation, Agitating, Pumping etc. The ultimate aim of this project is to automate and control the above process by designing a control system using Programmable Logic Controllers. Thus a Cost Effective design can be implemented wherein the expected consistency of Output Pulp, high Precision in Broke Loading and a perfect time cycle oriented process can be achieved.

II. INTRODUCTION

Paper mill is a factory that makes paper from vegetable fibers, wood pulp, old rags and other materials. Large scale paper mills produce nearly 4,00,000 tons of paper annually. The non ending demand for papers makes it necessary to minimize the losses and improve the efficiency of paper machine. Hence all paper mills recycle the wastes produced in each stage of paper production. Once such recycling process is broke feeding in finishing house pulper. About 10% of paper wastes called brokes are produced daily due to improper paper size, creases, etc. These wastes are converted back to pulp and send to pulp tower from where it will return to the initial stage to get converted back to paper. This will improve the production of the paper mill. This broke feeding process is carried out manually, by collecting all the brokes and then making it to pulp by mixing it using agitator. The pulp is then pumped to the pulp tower. By automating the broke feeding

the productivity of the paper mill can be increased. The collection of brokes cannot be automated. Hence the brokes are collected manually. The rest of the process can be automated using PLC. The broke feeding section has hydraulic lift, broke cage, broke remover, conveyor belt and an agitator. The sensors used are load cell and proximity sensor.

III. PROGRAMMABLE LOGIC CONTROLLER

A Programmable Logic Controller, PLC or Programmable Controller is a digital computer used for automation of electromechanical processes, such as control of machinery on large scale industries. The PLC is designed for multiple inputs and output arrangements, extensive temperature ranges, resistance to electrical noise, and resistance to vibration and impact.

Before the PLC, control, and sequencing for manufacturing automobiles was mainly composed of relays and timers, drum sequencers, and dedicated closed-loop controllers. Since these could number in the hundreds or even thousands, the process for updating such amenities for the yearly model change-over was very time consuming and expensive, as electricians needed to individually rewire relays to change the logic. Digital computers, being general-purpose programmable devices, are applied to control the industrial processes.

Early PLCs are designed to swap relay logic systems. These PLCs are programmed in "ladder logic", which strongly resembles a schematic diagram of relay logic. This program note was chosen to reduce training demands for the existing technicians. Other early PLCs used a form of instruction list programming, based on a stack-based logic solver. Modern PLCs can be programmed in a number of ways, from the relay-derived ladder logic to programming languages such as specially adapted dialect of BASIC and C. Another method is State Logic, a very high-level programming language designed to program PLCs based on state transition diagrams.

Many early PLCs did not have associated programming terminals that are capable of graphical representation of the logic, and so the logic was instead represented as a series of logic expressions in some version of Boolean format, related to Boolean algebra. As programming terminals evolved, it became more familiar for ladder logic to be used, for the abovementioned reasons and because it was a familiar format used for electromechanical control panels. New formats such as State Logic and Function Block (which is similar to the way logic is depicted when using digital integrated logic circuits) exist, but they are still not as popular as ladder logic. A principal reason for this is that PLCs work out the logic in a predictable and repeating sequence, and ladder logic allows the programmer to see any issues with the timing of the logic sequence more easily than would be feasible in other format.

The functionality of the PLC has evolved over the years to include sequential relay control, motion control, process control, distributed control systems and networking. The data handling, storage, processing power and communication capability of some modern PLCs is just about equivalent to desktop computers. PLC-like programming combined with remote I/O hardware, allow a general-purpose desktop computer to overlap some PLCs in certain applications. Concerning the reasonableness of these desktop computer based logic controllers, it is important to note that they have not been generally accepted in heavy industry because the desktop computers run on less stable operating systems than PLCs, and because the desktop computer hardware's are naturally not designed to the same levels of tolerance to high temperature, humidity, vibration, and durability as the processors used in PLCs.

In addition to the hardware limitations of desktop based logic, operating systems such as Windows do not lend themselves to deterministic logic execution, with the result that the logic may not always respond to changes in logic state or input status with the extreme consistency in timing as is expected from PLCs. Still, such desktop logic applications find use in less critical situations, such as laboratory automation and use in small facilities where the application is less difficult and critical, because they are generally much less expensive than PLCs.

IV. AUTOMATIC BROKE FEEDING SYSTEM

A. EXISTING SYSTEM

In a paper mill, there are several paper cutting machines and pulp mixer. They produced 1500 MT of paper per day. About 10% of this production will be considered as waste, due to incorrect GSM (paper size), paper cutting, etc. This waste papers are called as brokes. These kinds of wastes are recycled by the industry. Workers collect the whole broke, broke is nothing but the paper waste. This broke is brought to the finishing house pulper section. The brokes are then lifted to put the broke into the pulper. Then tap is opened till the water reaches the prescribed level. Next the mixer is started. The

whole process is done manually now. At least 3 workers are needed for this continuous process and it is also time consuming. This is the existing system for recycling the brokes in a paper mill. Fig 3 shows the existing broke feeding method in a paper mill.



Fig 3: Existing broke feeding technique

1) Block Diagram

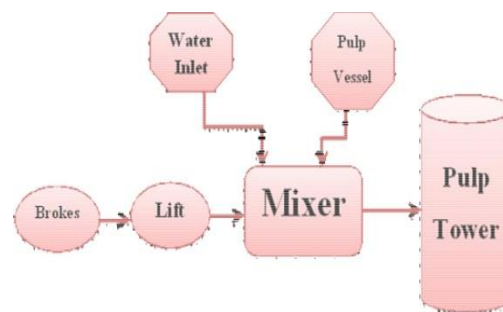

The brokes are collected from various stages of the paper machine. As the opening of the mixer is on the top the brokes are lifted using a lift. Then the brokes are transferred to the mixer manually. Also small paper wastes from various stages are brought to the mixer by pulp vessel. After the brokes are filled in the mixer, water is filled. Only 70% of the mixer is filled with water to avoid spilling. Then the agitator is turned ON. After thirty minutes the brokes will become pulp and will be transferred to pulp tower using a pump.

B. PROPOSED SYSTEM

The proposed system is automating the whole broke feeding process by using PLC. By automating the workers needed for broke feeding will be reduced to one. Also the time taken for recycling the brokes will also be reduced drastically. Thus the production of the paper mill can be increased.

- The sequence of operation of the proposed system will be as follows.
- The brokes will be collected and placed in the hydraulic lift.
- If the weight of the broke is between 150 kg and 200

kg, the lift will move up.

- When the lift reaches the prescribed height, the pusher and the conveyor starts operating.
- The pusher pushes the brokes to the conveyor, through which the broke reaches the pulper or mixer.
- Then the water inlet is opened till the water is filled upto the desired level.
- In the next sequence the agitator starts rotating. After the brokes are turned to pulper they are passed to the pulp tower.

1) Block Diagram

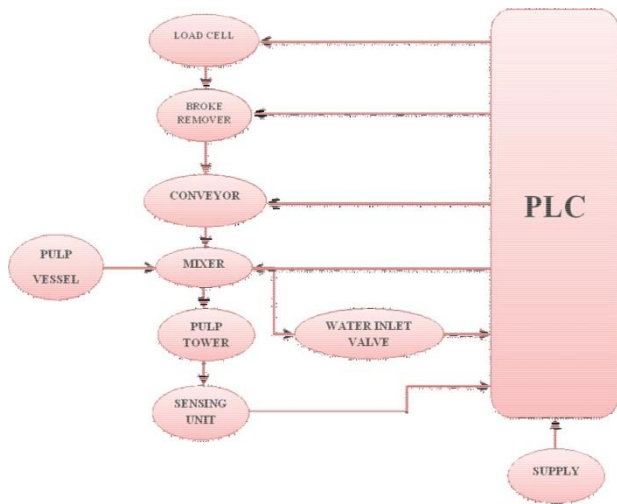

All the sensors or input devices will be connected to the PLC, which controls the output devices depending on the input. The load cell in the hydraulic lift will send signal to the PLC, if the weight of lift equals the predetermined value. The PLC then sends signal to move the lift up. When the lift reaches the top, the proximity sensor will check the alignment and sends signal to plc, which then turns on the broke remover and the conveyor. After the broke is pushed to mixer the water inlet valve will be opened for the desired time. After water is filled the agitator motor will be turned on.

2) Schematic Diagram

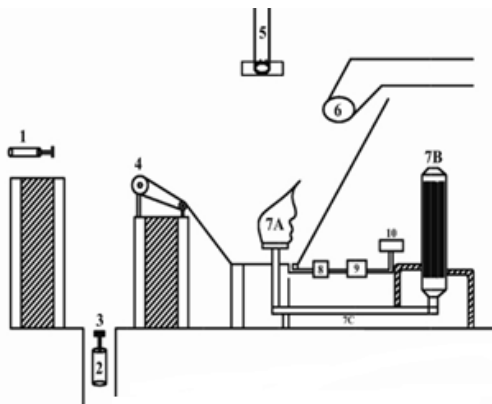

3) Parts Of Schematic Diagram

1. Broke Remover
2. Broke Cage Lift
3. Broke Cage
4. Broke Feeder (Conveyor)
5. Water Inlet Valve
6. Pulper Vessel
7. Mixer
 - a) Agitator Fins
 - b) Agitator Motor
 - c) Belt Coupling
8. Outlet Valve
9. Pump
10. Broke Pulp Tower

V. ELEMENTS OF BLOCK DIAGRAM

A. Agitator

An agitator is a device or mechanism to put something into motion by shaking or stirring. There are three main types of agitation machines the washing machine agitator, which rotates back and forth; the magnetic agitator, which contains a magnetic bar which rotates about a magnetic field; manual agitation, such as with a stirring rod.



B. Hydraulic Drive System

A hydraulic drive system is a drive or transmission system that uses pressurized hydraulic fluid to drive hydraulic machinery. The term hydrostatic refers to the transfer of energy from flow and pressure, not from the kinetic energy of the flow. A hydraulic drive system consists of three parts: The generator (e.g. a hydraulic pump), driven by an electric motor, a combustion engine or a windmill; valves, filters, piping etc. (to guide and control the system); the motor (e.g. a hydraulic motor or hydraulic cylinder) to drive the machinery.

C. Hydraulic Motor

The hydraulic motor is the rotary counterpart of the hydraulic cylinder. Conceptually, a hydraulic motor should be interchangeable with the hydraulic pump, due to the fact it performs the opposite function. However, most hydraulic

pumps cannot be used as hydraulic motors because they cannot be back driven. Also, a hydraulic motor is usually designed for the working pressure at both sides of the motor. Another difference is that a motor can be reversed by a reversing valve. Pressure in a hydraulic system is like the voltage in an electrical system and fluid flow rate is the equivalent of current. The size and speed of the pump determines the flow rate, the load at the motor determines the pressure.

D. Solenoid Valve

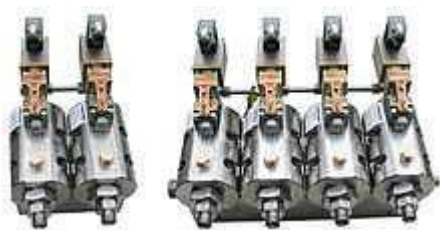

Fig 6: Solenoid Valves

A solenoid valve is an electromechanically operated valve. The valve is controlled by an electric current through a solenoid: in the case of a two-port valve the flow is switched on or off; in the case of a three-port valve, the outflow is switched between the two outlet ports. Multiple solenoid valves can be placed together on a manifold. Solenoid valves are the most frequently used control elements in fluidics. Their tasks are to shut off, release, dose, distribute or mix fluids. They are found in many application areas. Solenoids offer fast and safe switching, high reliability, long service life, good medium compatibility of the materials used, low control power and compact design. Besides the plunger-type actuator which is used most frequently, pivoted-armature actuators and rocker actuators are also used. Similarly, if the valve is closed when the solenoid is not energized, then the valve is termed normally closed. There are also 3-way and more complicated designs.

Solenoid valves are used in fluid powered pneumatic and hydraulic systems, to control cylinders, fluid power motors or larger industrial valves. Automatic irrigation sprinkler systems also use solenoid valves with an automatic controller.

VI. CONCLUSION

Paper mills have manual broke feeding system to recycle the waste, called brokes. Using this project the whole process is automated.

Using PLC it is very easy to handle the defects & future up gradation.

By the automation in the broke feeding system the man power used can also be reduced. Once this system is installed in the broke feeding process, it reduces 2 men's workload. So it is very useful to the paper mill for their recycling system.

It also reduces the time taken for broke recycling. Adding a quick convertible agitating system the speed of agitation

system also can be increased. Because now the rpm of the agitator motor is 1400. So it takes 30min (approx). Hence the automatic broke feeding system will improve the productivity and waste management of all the paper mills.

VII. REFERENCE

- D. Purcaru, I. M. Gordan and A. Purcaru, "Study, testing and application of proximity sensors for experimental training on measurement systems," 2017 18th International Carpathian Control Conference (ICCC), Sinaia, 2017, pp. 263-266.
- R. Kumar, P. K. Dwivedi, D. Praveen Reddy and A. S. Das, "Design and implementation of hydraulic motor based elevator system," 2014 IEEE 6th India International Conference on Power Electronics (IICPE), Kurukshetra, 2014, pp. 1-6.
- F. Basile, P. Chiacchio and D. Gerbasio, "On the Implementation of Industrial Automation Systems Based on PLC," in *IEEE Transactions on Automation Science and Engineering*, vol. 10, no. 4, pp. 990-1003, Oct. 2013.
- G. A. Smeu, "Automatic conveyor belt driving and sorting using SIEMENS step 7-200 programmable logic controller," 2013 8TH INTERNATIONAL SYMPOSIUM ON ADVANCED TOPICS IN ELECTRICAL ENGINEERING (ATEE), Bucharest, 2013, pp. 1-4.
- Liu Ying et al., "A quick convertible agitating system," 2010 International Conference on Mechanic Automation and Control Engineering, Wuhan, 2010, pp. 2276-2279.
- S. Ye and K. T. Chau, "Chaoization of DC Motors for Industrial Mixing," in *IEEE Transactions on Industrial Electronics*, vol. 54, no. 4, pp. 2024-2032, Aug. 2007.