

A novel battery and super capacitor using IoT to interface renewable energy sources with dual direction and its application

Mr.S.Sankarananth¹

Assistant professor

Dept. of EEE

Excel College of Technology

Komarapalayam, India

sankarananth99@gmail.com

Mr.K.Karthiga²

Assistant Professor,

Dept. of CSE

Bannari Amman Institute of Tech

Sathy, India

mkarthiga22@gmail.com

R.Nandhini³

U.G Student

Dept. of EEE

Excel College of Technology

Komarapalayam, India

nandhinir11997@gmail.com

A.Manju⁴

U.G Student

Dept. of EEE

Excel College of Technology

Komarapalayam, India

nandhini14ctee28@gmail.com

Abstract— A multi-input DC-DC help converter is proposed to get control from a few info sources and to supply the managed yield voltage to the heap from the sources. The information sources are the sustainable sources like sun based, wind, power module and vitality stockpiling frameworks like battery and super capacitor the IOT innovation was utilized as a part of this procedure to monitor and control. The battery used is bidirectional in its energy stream consequently the converter topology empowers the charging and releasing of the capacity component through information control sources .The task will be in the bidirectional route for the battery and the super capacitor .The control procedure proposed for this converter depends on stage move control and to manage the voltage to utilize PI controller. The proposed topology has the benefit of intrinsic bidirectional power stream, negligible number of transformation steps, high effectiveness and concentrated control can be executed.

Keywords—*Hybrid energy storage system (HESS), bidirectional dc-dc converter (BDC), battery, super capacitor, Solar, wind, fuel cell energy storage system (ESS), phase shift (PS).*

I. INTRODUCTION

There are five info ports the Bidirectional DC - DC converters (BDCs) effectively steps up or venturing down the voltage level between its information and yield alongside the ability of energy stream in both the bearings just or the battery and super capacitor. BDCs can be arranged into confined and non-secluded composes. Galvanic disengagement between multi-source frameworks is a prerequisite ordered by numerous models. Voltage coordinating if there should arise an occurrence of substantial voltage proportions between two sources, faculty

wellbeing, clamor lessening, impedance blocking ability and right activity of security frameworks are the primary explanations for galvanic detachment which is required by numerous delicate DC loads.

Normal IBDC topology is Dual Active Bridge (DAB) topology in which full extension voltage nourished converters are utilized at both the finishes of the segregation transformer. Keeping in mind the end goal to interface different sustainable power sources or to interface various vitality stockpiling frameworks with the heap; multiport confined bidirectional dc-dc converters are finding their expanding applications. Hybrid Energy Storage System (HESS) – battery and super capacitor mix are finding their promising application in cross breed and power module controlled Electric Vehicles (EV) , shrewd matrix, extensive scale wind and photovoltaic frameworks Uninterruptible Power Supplies (UPS) and so forth [9]. The ideal decision of development for this kind of HESS is triple dynamic full extension (TAB) topology [8],[9],[10] which is gotten from double dynamic scaffold (DAB) topology [1].

In [5] diverse structures of multiport converters is introduced to interconnect various sources. Isolate dc-dc converters are utilized for singular sources. These converters are connected together at the DC transport and controlled autonomously. However, a downside of this structure lies in the

way that it is innately mind boggling and has high cost because of various transformation stages. Multiport structure both the DC interface and the attractive coupling are joined to such an extent that entire framework is dealt with as single power converter in which concentrated control can be executed with insignificant number of transformation steps in light of the fact that here the framework assets are shared.

Three port triple half scaffold bidirectional dc-dc converter is displayed in [4] that interface super capacitor, energy component and load. In any case it has just bidirectional port subsequently it doesn't bolster regenerative load. Half scaffold setup has of the converter has restrictions from the view purpose of energy rating, since high recurrence of current needs to go through the half extension capacitors in full. More finished because of wide working extent at the battery or super capacitor port limits the wide zero voltage exchanging (ZVS) run. Three port current bolstered full extension bidirectional converters which has the benefit of lessened current swell at the contribution because of the nearness of info inductor is introduced in [8]. The disadvantage of this topology is that it is reasonable just for low power and low yield voltage applications. In spite of the fact that the channel necessities are less it builds the control many-sided quality of the circuit.

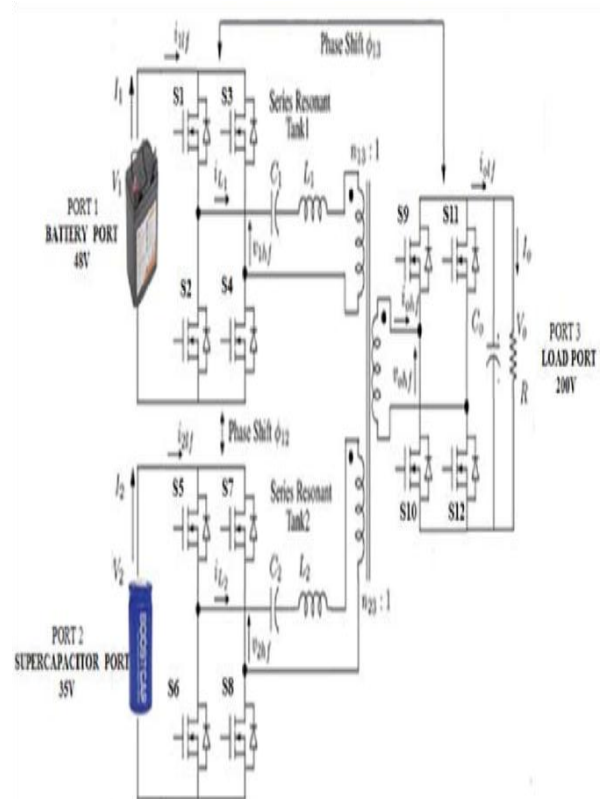

Fig. 1. Multiport isolated bidirectional dc-dc converter

Three port bidirectional converter for half breed energy unit framework is introduced in [11] in which the full extensions work in square wave mode stage moved from each other. One of the downside of this converter is that the exchanging recurrence and the inductor esteems can't be resolved autonomously for a similar power level. An arrangement resounding three port converter with stack side diode connect is exhibited in [10] in which every one of the ports are voltage encouraged ports. ZVS is conceivable in this converter with the end goal that exchanging misfortune diminishes. In any case, the disadvantage of this converter is ZVS isn't feasible for stack side port and not reasonable for regenerative load. More finished to get estimations of inductors more than the spillage inductance of the transformer the changing recurrence should be decreased. With a specific end goal to beat these disadvantages an arrangement resounding triple dynamic full scaffold topology is proposed in this paper in which all the voltage bolstered ports are bidirectional that interfaces battery which goes

about as essential stockpiling and super capacitor which goes about as transient stockpiling.

II. PROPOSED TRIPLE ACTIVE BRIDGE CONVERTER

A. Circuit Construction

The proposed triple dynamic extension bidirectional dc-dc converter circuit comprises of three dynamic full scaffolds as appeared in fig.1, three winding transformer and two arrangement thunderous tanks framed by L1, C1 and L2, C2. Battery is utilized as Energy Storage System 1 and super capacitor is utilized as Energy Storage System 2. Port 1 is nourished by battery port and port 2 is bolstered by super capacitor. Port 3 is load port (Resistive load and DC motor load). Each port consists of full bridge circuit with four switches. The switches are realized using MOSFET enabling bidirectional current flow in all the ports. The three winding transformer is mostly a step-up transformer. It has three functions (1) combines input DC sources in magnetic form, (2) provides electrical isolation, (3) step up voltage from Low Voltage Side (LVS) to High Voltage Side (HVS). 4) leakage inductance acts as energy transfer elements. The converter is operated at constant switching frequency F_S above the resonant frequency F_r . Phase move control system is the customary control procedure which is generally actualized in BDCs converters. TAB BDCs utilizes the stage move ϕ between the voltage crosswise over the two sides of the separation transformer to control the exchange of energy through the components of the thunderous tank. When utilizing this control system all the switches of the converter are driven at half obligation cycle. The switches of port 1 M1, M4 and M2, M3 are controlled integrally. The switches of port 2 M5, M8 and M6, M7 are controlled correspondingly. Essentially the switches of port 3 M9, M12 and M10, M11 are controlled correspondingly. The two stage move control factors ϕ_{12} and ϕ_{13} considered. They control the stage move between the square wave yields of the dynamic extensions. The stage shifts ϕ_{12} and ϕ_{13} considered positive if V_{ohf}

slacks V_{1hf} and V_{1hf} slacks V_{2hf} separately. The essential voltages V_{1hf} and V_{2hf} either (+V1 or - V1) and (+V1 or - V2) and the optional voltage V_{ohf} is either (+V0/2n) or (-v0/2n). The admired key exchanging waveform for stage move control system is appeared in fig.2.

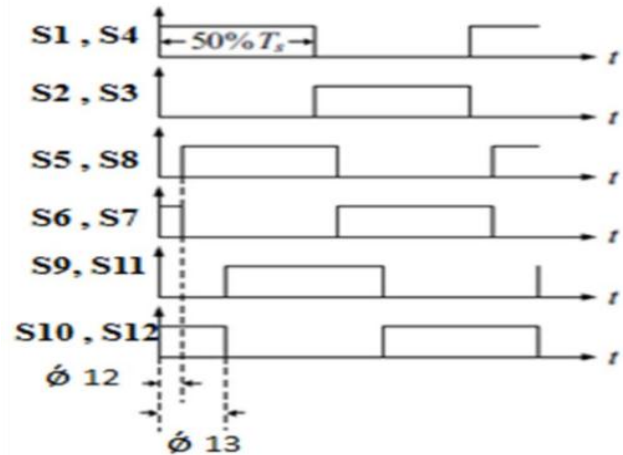

Fig. 2. Idealized key switching waveform for phase shift control

III. PROPOSED BLOCK DIAGRAM

The multiport dc-dc converter for synchronously power transfer from multiple renewable energy sources uses only one power electronic switch in each input port connected to a source. The introduced converter does not use any controllable switch on the secondary side of the transformer [2]-[4]. The proposed converter has the least numbers of switches and thereby a lower cost. The newly introduced converter is applied for power management of a wind/solar hybrid generation systems, which consists of a WTG and two varied PV panels. The power generation from solar and wind energy are designed using perturbation and observation (P&O) MPPT algorithm, in which the WTG and PV panels can be controlled at the same time and extract the maximum power. The Figure shows the block diagram of the introduced multiport DC-DC converter. It consists of PV Panels, Wind turbine generator, Boost converter, MPPT controller, High frequency transformer and an inverter.

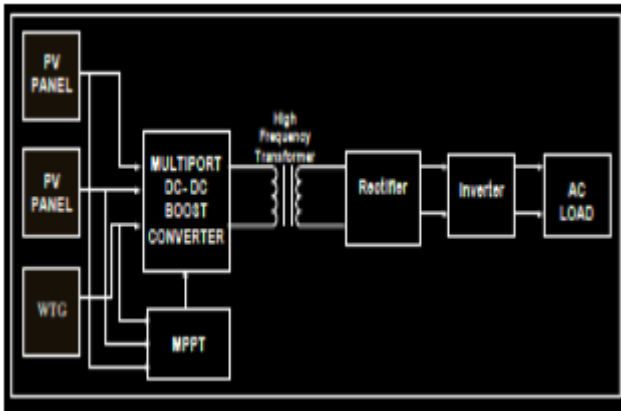

Fig.3. Block Diagram Multiport DC-DC Converter.

IV. MODES OF OPERATION

The task of the proposed TAB converter depends on the two noteworthy imperatives.

1) When the port supplies energy to the heap i.e. when the port goes about as source it goes about as inverter. (releasing mode).

2) When the port sinks control i.e. charging mode it goes about as rectifier.

Here the methods of activities has three sort of modes, here they spoke to as mode A, mode B and mode C. One mode will demonstrates the task of the battery with the heap and another mode demonstrates the activity of super capacitor with the heap and mode C will clarifies about the task of the bidirectional activity of the battery and super capacitor with the heap.

A. Mode 1

In mode 1 both port 1 and port 2 supplies the heap port. Both the battery port and super capacitor port is in releasing mode as appeared in fig.3. The stage move between port 1 and port 2 Φ is 00. The stage move amongst port1 and port 3 Φ_{13} is 240Port 1 goes about as inverter since it supplies control. MOSFET switches M1, M4 for positive mode or MOSFET switches M5, M8 for positive Here the task clarifies about the working of the battery and the super capacitor in a bidirectional way. Other sources like the sun based vitality, wind energy and the fuel vitality won't have the bidirectional operations. so on account of this M2, M3 for negative mode conducts. Port 2 acts as inverter. Reason just the activities of battery and

super capacitor bidirectional with the heap had clarified here. mode or M6, M7 for negative mode conducts. Port 3 goes about as rectifier since it sinks power with the end goal that anti parallel diodes of MOSFET switches comes vigorously by the procedure of synchronous correction. Anti parallel diode D9, D12 conducts for positive mode or the anti parallel diode D10, D11 conducts for negative method of activity. Port 1, port 2 and port 3 control is sure when the converter works at mode 1.

B. Mode 2

In mode 2 the power provided by port 2 to the heap is zero. Port 1-Battery port supplies the port 2-Supercapacitor port and also supplies the R-stack as appeared in fig.4 and consequently it goes about as inverter. The stage move between port 1 and port 2 Φ_{12} is 67.50. The stage move amongst port1 and port 3 Φ_{13} is 51.50. Port 2 and port 3 goes about as rectifier since it is provided by the battery port. A since the port 2-Supercapacitor port is in charging mode, the yield energy of port 2 is negative.

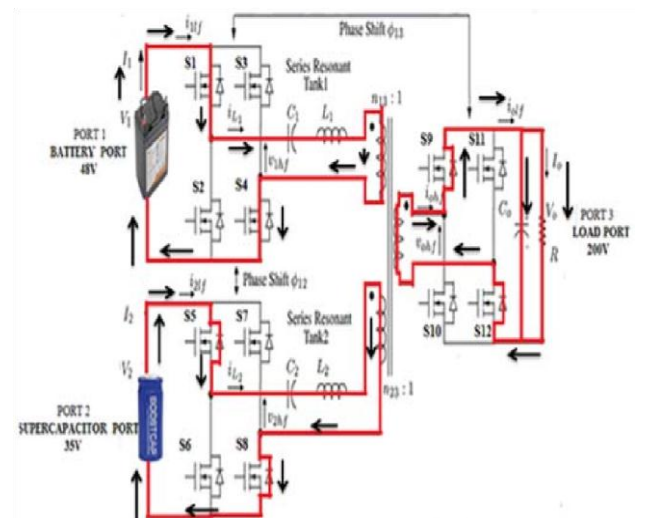
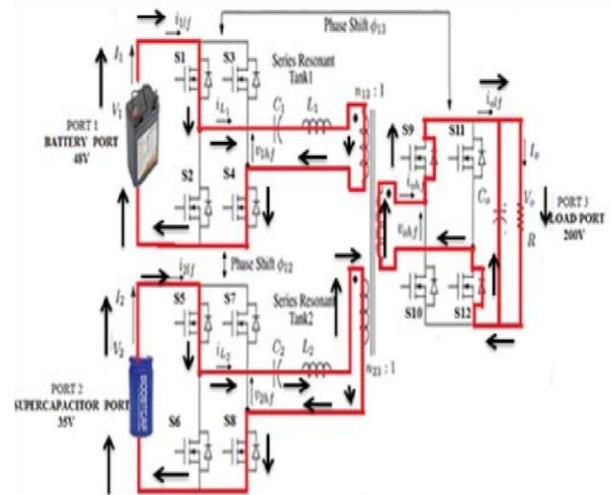

In mode 3 port 1 and 2 are charged by the DC-engine. Control is nourished from the regenerative load when the produced emf is more prominent than the terminal voltage. This power streams in the invert heading through port 3 to the port 1 and port 2 along these lines battery and super capacitor will get charged as appeared in fig. 5 and subsequently these ports will go about as rectifier. The stage move between port 1 and port 2 Φ_{12} is 240. The stage move amongst port 1 and port 3 Φ_{13} is 00. Port 3 goes about as inverter.

IV.ANALYSIS AND DESIGN

For design of proposed multiport isolated bidirectional dc- dc converter the frequency factor of 1.1 is chosen and the quality factor of 4 is chosen [2] for the design purpose and it is calculated from the following equations.

$$\text{Frequency ratio} = \frac{WS}{wi} = \frac{2 \cdot \pi \cdot fs}{\sqrt{LiCi}} \tag{1}$$

$$\text{Quality factor } Qi = \frac{Z1}{\frac{8 \cdot R \cdot N12}{\pi^2}} \tag{2}$$

$$\text{Impedance } zi = \sqrt{\frac{Li}{Ci}} \tag{3}$$

The inductor values for series resonant tank is calculated from the following equation [7] and the value of capacitor is chosen such that frequency factor is 1.1.

$$Li = \frac{Vi \cdot Vi \cdot T}{162 \cdot P} \tag{4}$$

Where T is the time period and p is the output power in watts. The output voltage, current and power is calculated from the following equation

$$V_0 = \frac{V1 \cdot \sin \Phi_{13}}{Q1 \left(F1 - \frac{1}{F1}\right)} + \frac{V2 \cdot \sin(\Phi_{12} - \Phi_{13})}{Q1 \left(F1 - \frac{1}{F1}\right)} \tag{5}$$

$$I_0 = \frac{8}{\pi^2} \cdot \frac{V1 \cdot \sin \Phi_{13}}{Q1 \left(F1 - \frac{1}{F1}\right)} + \frac{8}{\pi^2} \cdot \frac{V2 \cdot \sin(\Phi_{12} - \Phi_{13})}{Q1 \left(F1 - \frac{1}{F1}\right)} \tag{6}$$

If the load is resistive load then output power is calculated as

$$P_0 = I_0 \cdot I_0 \cdot R \tag{7}$$

Degree of phase shift Φ_{13} between port 1 and 2 and Φ_{12} between port 1 and 2 is calculated from the following equation.

$$\Phi_{13} = \frac{\sin^{-1} \left(\frac{Z1 \left(F1 - \frac{1}{F1} \right)}{V_0 \left(F1 - \frac{1}{F1} \right) N13 \left(\frac{8}{\pi^2} \right)} \right)}{\dots} \tag{8}$$

$$\Phi_{12} = \frac{\Phi_{13} - \sin^{-1} \left(\frac{8}{\pi^2} \cdot N13 V_1 \left(\sin \Phi_{13} \right) \right)}{\frac{\left(\frac{8}{\pi^2} \right) N13 V_2}{Z1 \left(F1 - \frac{1}{F1} \right)}} \tag{9}$$

Super capacitor bank of 35 volt is modelled by connecting 13 super capacitor cells each of 2.5 volt. In order to increase the net energy capacity of the super capacitor bank 14 cells are connected in parallel In order to increase the net energy density, the number of parallel connected cells should be higher than the number of series connected cells [12]. The total of 182 cells is used to model a super capacitor bank of 35 volts Lead acid battery of 48 volt with 12 ampere hour rating is modelled to act as dc source for port 1.

TABLE I. CONVERTER DESIGN SPECIFICATIONS

PARAMETERS	VALUES
Port 1-Battery port input voltage	48 Volts
Port 2-Supercapacitor port input voltage	35 Volts
Port 3- Load port output voltage	200 Volts
Switching frequency ^	100 KHZ
Turns ratio between port 1 and 3 \square	0.24
Turns ratio between port 2 and 3 \square	0.18
Inductance of series resonant tank 1	28.44 μ H
Inductance of series resonant tank 2	15 μ H
Capacitance of series resonant tank 1	0.1 μ F
Capacitance of series resonant tank 2	0.22 μ F
Output Current	2.6 A
Output Power	500 Watts
Resistance R	80 Ω

TABLE II.SUPERCAPACITOR CELL SPECIFICATIONS

PARAMETERS	VALUES
Equivalent capacitance of the Super capacitor cell	50 Farads
Voltage rating of the Super capacitor cell	2.7 Volts
Equivalent DC Series Resistance ESR	20 mA
Maximum surge voltage of a cell	2.85 Volts
Maximum leakage current	0.075 mA

TABLE III. BATTERY DESIGN SPECIFICATIONS

PARAMETERS	VALUES
Battery voltage	48 Volts
Ampere – hour rating	12 Ah
Initial state of charge	90 %

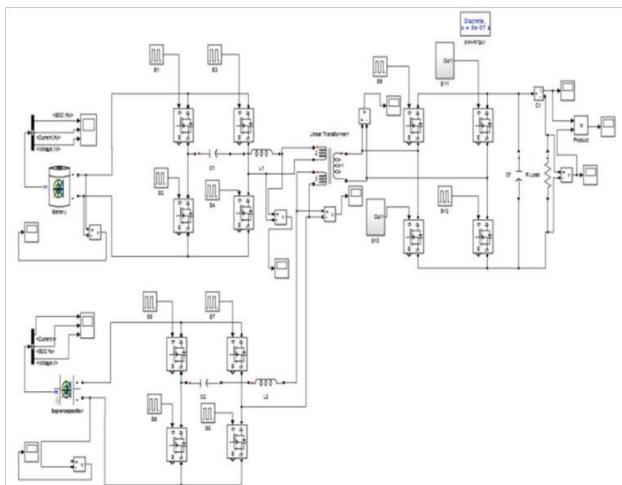

Fig. 4. Simulation diagram of multiport isolated bidirectional dc-dc converter with R-load for mode 1 and 2 operation



Fig.5.Mode 1 – Gate signal for switches S1, S4,S5,and S8

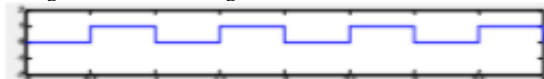

Fig.6.Mode 1 – Gate signal for switches S2, S3, S6, S7



Fig.7.Mode 1 – Gate signal for switches S9,S12

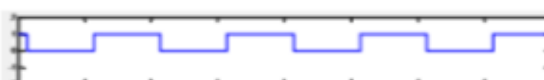

Fig.8 .Mode 1 – Gate signal for switches S10,S11



Fig.9 .port 1- Battery port input voltage

V. SIMULATION RESULTS

A. Open loop simulation results

In Fig 5 the simulation circuit diagram of multiport isolated bidirectional dc-dc converter is shown with battery as input for port 1 of 48 V and super capacitor as a input for port 2 of 35 V and port 3 is the load port (R- load for mode 1 and 2 and DC motor load for mode -3) of 200 V. All the three ports are active bridges the switches are realized using MOSFETS. Simulation for mode 1 operation in which both battery and super capacitor supplies the resistive load. Load port output voltage and current for mode 1 operation is shown in fig. 11 and 12. In fig. 5,6,7,8, X-axis represents voltage in volts and Y-axis represents time in seconds

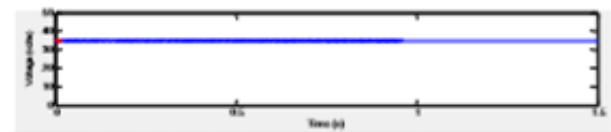

Fig.10 port 2- Super capacitor port input voltage



Fig.11 port 3- load port input power

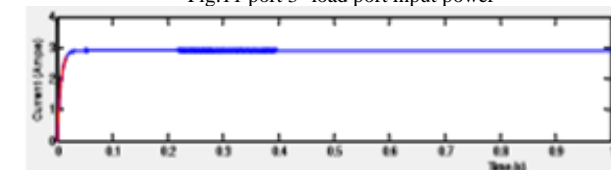

Fig.12 port 3 - load port output current

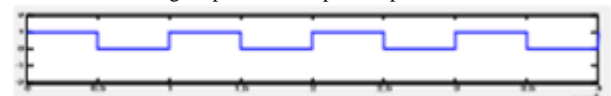

Fig.13. Mode 2 – Gate signal for switches S1,S4

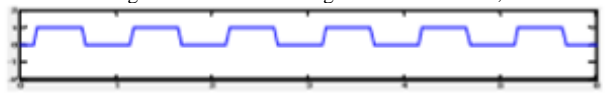

Fig.14. Mode 2 – Gate signal for switches S5,S8

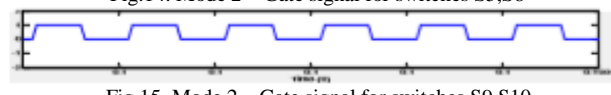

Fig.15. Mode 2 – Gate signal for switches S9,S10

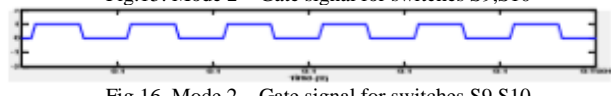

Fig.16. Mode 2 – Gate signal for switches S9,S11

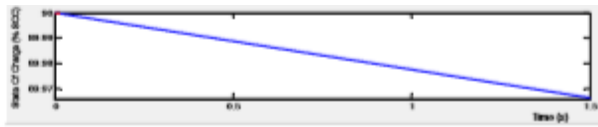

Fig.17. port 1- Battery state of stage

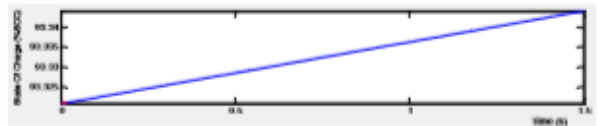

Fig.18. port 2- Super capacitor state of stage

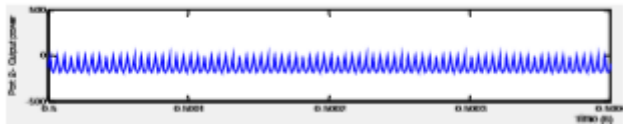

Fig.19 port 2- Super capacitor port output power

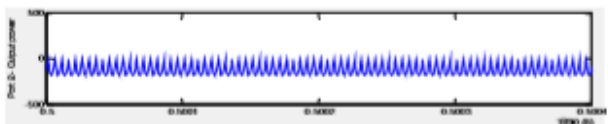

Fig.20 port 2- Super capacitor port output power



Fig.21 port 3- load port output power

Simulation result for mode 2 operation is shown above in which battery is in discharging mode since it supplies load and super capacitor. Load gets reduced by half as shown in fig.21 since it is supplied by port 1 alone. state of charge of battery is decreasing as shown in fig. 18 and super capacitor is in charging mode as shown in fig.19, state of charge of super capacitor is increasing from its initial value of 93%.

Fig. 22. Simulation circuit diagram with DC motor load for mode 3 operation

From the fig. 20 it is inferred that the super capacitor port sinks power so that the output power of port 2 is negative of the value of -189 watts. In fig. 15, 16, 17, X-axis represents voltage in volts and Y-axis represents time in seconds. Gating signal for opposite pair of switches of each port are controlled complementarily Simulation result for mode 3 operation is shown in which both the battery and super capacitor is charged by the DC motor load which acts as DC-generator in regenerative mode

as shown in fig. 25 and 26 the state of charge of both battery and super capacitor is increasing. In regenerative mode power is negative so the torque is negative of - 42 N-m as shown in fig. 27 and the speed is positive of 16 rad / sec as shown in fig.28. From these results bidirectionality and regenerative operation is inferred.

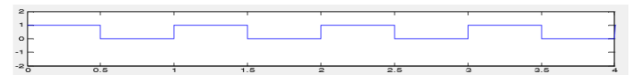

Fig. 23. Mode 3 - Gating signal for switches S1, S4, S9, S12

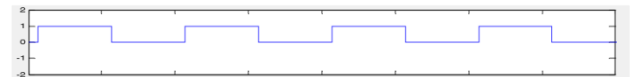

Fig. 24. Mode 3 - Gating signal for switches S5, S8

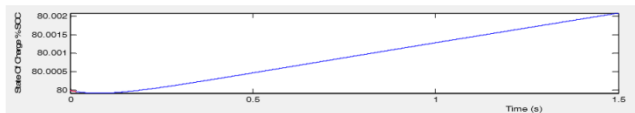

Fig. 25. Mode 3 - Port 1 – Battery port state of charge

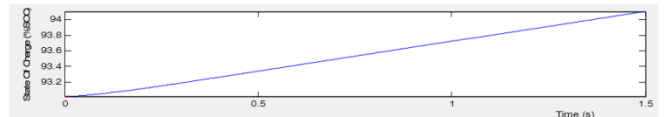

Fig. 26. Port 2 – Supercapacitor port state of charge

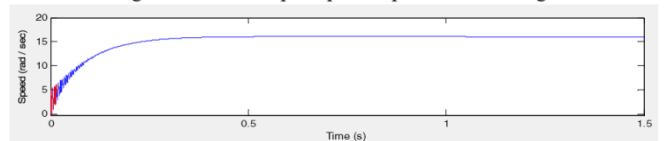

Fig. 27. DC motor speed

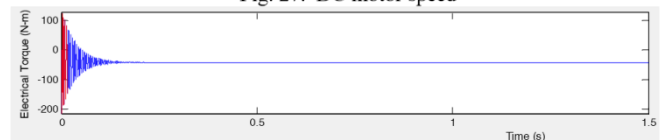
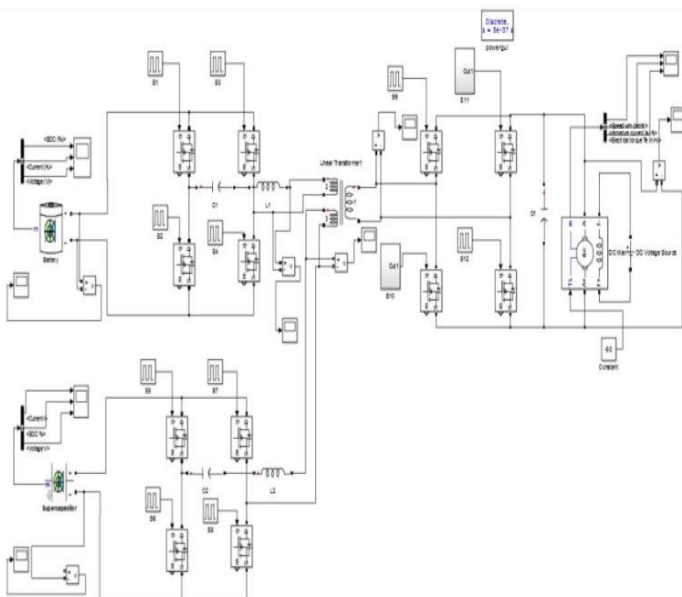

Fig. 28. DC motor torque



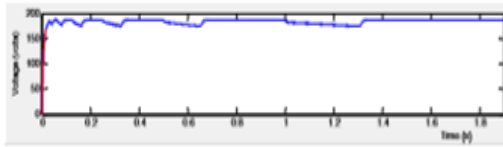

Fig.29 port 3- load port output voltage

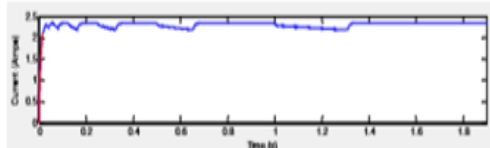

Fig.30 port 3- load port output current

In fig. 23,24, X-axis represents voltage in volts and Y-axis represents time in seconds. Gating signal for opposite pair of switches of each port are controlled complementarily. In Closed loop control technique the gating signals are controlled with the help of Proportional plus Integral (PI) controller as shown in fig. 29 . The output voltage from port 3 is compared with the reference voltage signal of 200 Volts. The error signal from the comparator is fed to the PI regulator where the error signal is regulated and fed to the input side. Such that despite of any changes in the input side parameters the output side parameters is made constant. With phase shift control technique in closed loop simulation the output voltage obtained is 187 volts and output current is 2.3 amps as shown in fig. 30 and fig.31 but the expected voltage is 200 Volts and output current is 2.5 amps. This might be due to the drawbacks of phase shift control technique which is overcome in the pulse width modulation plus phase shift control technique which is extended future work.

CONCLUSION

A multiport dc-dc converter in which multiple ports are voltage fed ports is proposed in this paper to interface multiple energy storage systems such as battery and super capacitor. It is shown that from the analysis and simulation results the power flow between the ports can be controlled by the series resonance and phase shifting the square wave outputs of the three active bridges. With this technique there exists a drawback such as secondary side voltage overshoot due to voltage mismatch between the input and output side of the input ports, In order to overcome the drawback of phase shift control technique pulse width

modulation plus phase shift control technique is to be implemented which is feature work.

REFERENCE

- [1] Amari Mansour, Bacha Faouzi, Ghouili Jamel and Elgharbi Ismahen, "Design and analysis of high frequency dc-dc converters for fuel cell and super-capacitor used in electric vehicle," International Journal Of Hydrogen Energy, ELSEVIER, vol. 39, pp.1580-1592, May 2014.
- [2] B.S. Nathan and V.R. Ramanarayanan "Analysis simulation and design of series resonant converter for high voltage applications", Proceedings of IEEE International Conference on Industrial Technology, vol. 1, no. 2, pp.688-693, December 2000.
- [3] C. Zhao and J.W. Kolar, "A novel three phase three port UPS employing a signal high frequency isolation transformer," in proc. IEEE. Power Electronics Specialists Conference (PESC), Aachen, Germany, pp.4135-4141, June 2005.
- [4] Haimin Tao, A. Kotsopoulos, J.L. Duarte and M.A.M. Hendrix, "Triple half-bridge bi-directional converter controlled by phase shift and PWM," in Proc. IEEE Appl. Power Electron. Conf. Expo (APEC), pp.1256-1262, 2006.
- [5] Haimin Tao, A. Kotsopoulos, J.L. Duarte and M.A.M. Hendrix, "Family of multiport bi-directional dc-dc converters," IEEE Proc - Electr. Power Appln., vol. 153, no.3, pp.451-458, May 2006.
- [6] H. Al Atrash, F. Tian and I. Batarseh, "Tri-modal half-bridge converter topology for three port interface," IEEE Trans. Power Electron, vol. 22, no.1, pp.341-345, January 2007.
- [7] Haimin Tao, J.L. Duarte and M.A.M. Hendrix, "Three port triple half bridge bidirectional converter with zero voltage switching," IEEE Trans. Power Electron., vol. 23, no.2, pp.782-791, March 2008.
- [8] H. Krishnaswami and N. Mohan, "A current-fed three port bi-directional dc-dc converter," in proc. IEEE Int. Telecommun. Energy conf. (INTELEC), pp.523-526, 2007.

- [9] H. Krishnaswami and N. Mohan, "Constant switching frequency series resonant three port bi-directional dc-dc converters", in Proc. IEEE Power Electron. Spec. Conf. (PESC), pp.1640-1645, 2008.
- [10] H. Krishnaswami and N. Mohan, "Three port series-resonant dc-dc converter to interface renewable energy sources with bidirectional load and energy storage ports", IEEE Trans. Power Electron., vol. 24, no.10, pp.2289-2297, October 2009.