



Power System Operation and Control Using Facts Devices

S.Natarajan¹, G.Nishanth², T.Ananth Raj³, A.Venkatesh⁴, M.Prabhu⁵
¹Assistant Professor, ^{2,3,4,5}UG students, Department of Electrical and Electronics Engineering
 VEL TECH, Chennai-600062
 Email: jayasuriya9407@gmail.com¹

ABSTRACT: In recent years, power demand has increased substantially while the expansion of power generation and transmission has been severely limited due to limited resources and environmental restrictions. As a consequence, some transmission lines are heavily loaded and the system stability becomes a power transfer-limiting factor. Flexible AC transmission systems (FACTS) controllers have been mainly used for solving various power system steady state control problems. However, recent studies reveal that FACTS controllers could be employed to enhance power system stability in addition to their main function of power flow control. The literature shows an increasing interest in this subject for the last two decades, where the enhancement of system stability using FACTS controllers has been extensively investigated. This paper presents a comprehensive review on the research and developments in the power system stability enhancement using FACTS damping controllers. Several technical issues related to FACTS installations have been highlighted and performance comparison of different FACTS controllers has been discussed.

KEY WORDS : power system stability, PSS, FACTS, SVC, TCSC, TCPS, STATCOM, SSSC, UPFC

1.INTRODUCTION:

According to IEEE definition it is defined as “: Alternating current transmission systems incorporating power-electronic based and other static controllers to enhance controllability and increase power transfer capability. The need for more efficient and fast responding electrical systems has given rise to innovative technologies in transmission using solid-state devices. These are called FACTS devices which enhance stability and increase line loadings closer to thermal limits. The development of power semiconductor devices with turn-off capability (GTO, MCT) opens up new perspectives in the development of FACTS devices. FACTS devices are the key to produce electrical energy economically and environmental friendly in future.

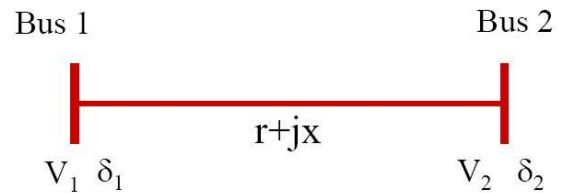

Fig 1

Real power and reactive power can be written as :
 Real and reactive power flows are functions of voltage, phase angle differences and impedances, especially the reactance of the transmission lines.

- Real and reactive power can be controlled by controlling phase angle and voltage magnitude, respectively.
- Alternately real and reactive power can be controlled by controlling the impedance of the line, especially, the imaginary part with series compensation

2.POWER SYSTEM STABILITY:

Stability of an interconnected power system is its ability to return the normal or stable condition after has been subjected to some form of disturbance.

2.1 TRANSIENT STABILITY AND STEADY STATE STABILITY:

Transient stability is defined as the ability of the power system to maintain synchronism when subjected to severe transient disturbance . A system is transiently stable if it can survive the initial disturbance but it is transiently unstable if it cannot survive. For the transiently stable system, a large disturbance suddenly occurs; the system angle spread starts to increase but reaches a peak and then starts to decline, making the system transiently stable. The

resulting system response involves large excursions of generator rotor angles. Transient stability is sometimes called first swing stability as the instability often occurs during the first angle swing. It is basically concerned with the determination of the upper limit of machine loading

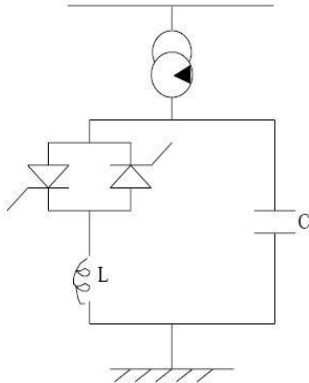

before losing synchronism.

3.FACTS CONTROLLER:

A power electronic-based system and other static equipment that provide control of one or more ac transmission system parameters

There are 4 types of controller are there in facts controller:

1. Series controllers.
2. Shunt controllers.
3. Combined series-series controllers.
4. Combined series-shunt controllers.

According to there classifications facts controller can be broadly in to 3 categories:

- Traditional FACTS
- Voltage Source converter (VSC) based FACTS
- Others

3.1 TRADITIONAL FACTS: Combination of capacitor and inductor along with power electronic switches.

- i) SVC (Static Var Compensators)
- ii) TCSC (ThyristorControlled Series Compensators)

3.2 VSC BASED FACTS CONTROLLER:

- i) STATCOM (Static Synchronous Compensator)
- ii) SSSC (Static Synchronous Series Compensator)
- iii) UPFC (Unified Power Flow Controller)

3.3 OTHERS:

- i)TCPAR (Thyristor Control Phase Angle Regulators)
- ii)TCVL(ThyristorControlled Voltage Limiters)
- iii)TSBR(Thyristor Switched Breaking Resistors) iv)TCPST (ThyristorControlled Phase Shifting Transformers)

4.FIRST GENERATION OF FACTS:

SVC and TCSC are generally categorized as first generation of facts.

4.1 STATIC VAR COMPENSATOR:

This compensator consists of a fast thyristor switch controlling a reactor and/or shunt capacitor bank, to provide dynamic shunt compensation .SVC is a shunt connected static var generator/load whose output is adjusted to exchange capacitive or inductive current so as to maintain or control specific power system variables.

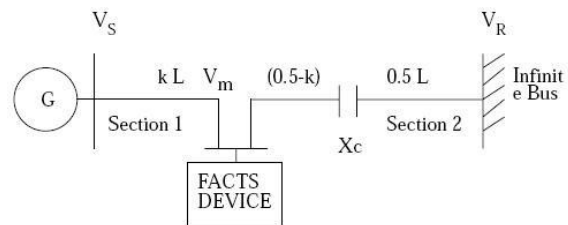
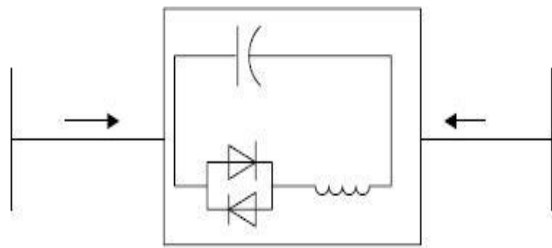

Fig 2:series compensated transmission line with a shunt FACTS devices

4.2 THYRISTER CONTROLLED SERIES CAPACITOR:

Thyristor Controlled Series Capacitor (TCSC) is a later member of the first generation of FACTS devices, that uses silicon controlled rectifiers to manage a capacitor bank connected in series with a line. TCSC allows utility to transfer more power further on a particular line.it control the reactive powers deliver/absorbed by devices. TCSC can be used for

- Oscillation damping
- To increase power transfer capability
- Sub synchronous Resonance



system at the point of connection. As long as the injected current is in phase quadrature with the line voltage, the shunt controller only supplies or consumes variable reactive power. Any other phase relationship will involve handling of real power as well. Static Synchronous Compensator (STATCOM) is one such controller.

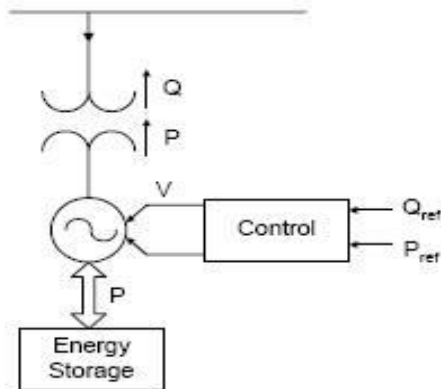

Fig 4:schematic diagram of TCSC

Maximum system voltage	550kv
Nominal reactive power	107 MVAR
Rated current	1500 A
Rated continuous voltage	23,9 KV
Physical capacitor reactance	13,3 Ω
Nominal compensation degree	5%

Table 1:rated value of TCSC
TCSC can be used for

- Oscillation damping
- To increase power transfer capabilities
- Subsynchronous resonance

5.SECOND GENERATION OF FACTS:
STATCOM,SSSC & UPFC are categorized as 2nd generations of facts devices.

5.1 STATIC SYNCHRONOUS COMPENSATOR (STATCOM):

STATCOM is the voltage-source converter, which converts a DC input voltage into AC output voltage in order to compensate the active and reactive needed by the system. STATCOM has several advantages of being small/compact, high response speed and no harmonic pollution.

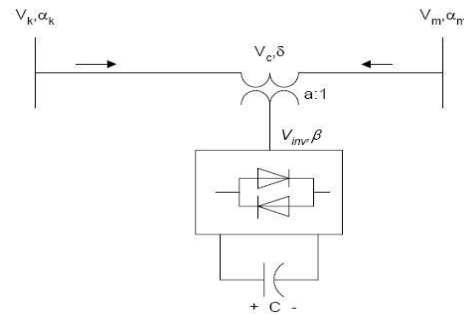

Fig 5:schematic diagram of STATCOM

5.2 STATIC SYNCHRONOUS SERIES COMPENSATOR (SSSC):

SSSC is the solid-state synchronous voltage source employing an appropriate DC to AC inverter with gate turn-off thyristor used for series compensation of transmission lines.

The series controller could be a variable impedance, such as capacitor, reactor, etc., or a power electronic based variable source of main frequency, sub synchronous and harmonic frequencies to serve the desired need. They inject voltage in series with the line. As long as the voltage is in phase quadrature with the line current, the series controller only supplies or consumes variable reactive power. Any other phase relationship will involve handling of real power as well. Static Synchronous Series Compensator(SSSC) is one such series controller.

5.3 UNIFIED POWER FLOW CONTROLLER (UPFC):

Two inverters, namely shunt inverter and series inverter which operate via a common dc link with a control active and reactive power flows on the line as well as the bus voltage.

This could be a combination of separate shunt and series controllers, which are controlled in a coordinated manner, or a unified power flow controller with series and shunt elements. In principle, combined shunt and series controllers

inject current into the system with shunt part of the controller voltage in series in the line with the series part of the controller. However, when the shunt and series controllers are unified, there can be a real power exchange between the series and shunt controllers via the power link.

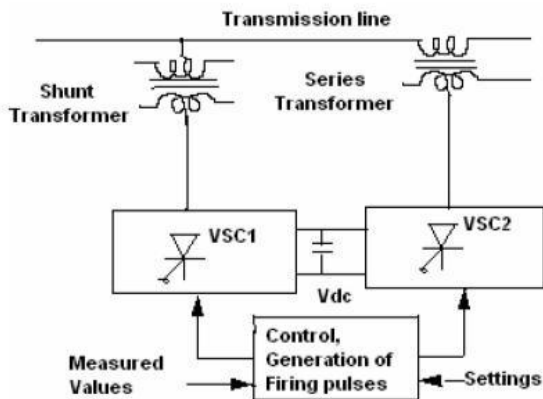

Fig 6:arrangement of UPFC

6.1 STEADY STATE APPLICATION

Various steady state applications of FACTS controllers includes voltage control (low and high), increase of thermal loading, post-contingency voltage control, loop flows control, reduction in short circuit level and power flow control. SVC and STATCOM can be used for voltage control while TCSC is more suited for loop flow control and for power flow control.

6.2 DYNAMIC APPLICATION

Dynamic application of FACTS controllers includes transient stability improvement, oscillation damping (dynamic stability) and voltage stability enhancement. One of the most important capabilities expected of FACTS applications is to be able to reduce the impact of the primary disturbance. The impact reduction for contingencies can be achieved through dynamic voltage support (STATCOM), dynamic flow control (TCSC) or both with the use of UPFC.

6.3 TRANSIENT STABILITY ENHANCEMENT

Transient instability is caused by large disturbances such as tripping of a major transmission line or a generator and the problem can be seen from the first swing of the angle. FACTS devices can resolve the problem by providing fast and rapid response during the first swing to control voltage and power flow in the system

6.4 DYNAMIC VOLTAGE CONTROL

Shunt FACTS controllers like SVC and STATCOM as well as UPFC can be utilized for dynamic control of voltage during system contingency and save the system from voltage collapse and blackout.

6.5 APPLICATION IN DEREGULATED ENVIRONMENT

Apart from its traditional application for voltage control, power flow control and enhancing steady state and dynamic limits, FACTS controllers are finding new applications in the present deregulated environment. One of the applications is in controlling the “parallel flow” or “loop flow”. Loop flow results in involuntary reduction in transmission capacity that may belong to some other utility and hence foreclose beneficial transactions through that line. Utilities can also make use of FACTS controllers in their tie lines, either to shield it from the neighbouring effects, such as wheeling transactions or to participate in such transaction. FACTS devices can also be implemented to ensure the economy in operation by placing it in a suitable line such that least cost generators can be dispatched more. It can also be used to reduce the losses in the system. Yet, another application is to use FACTS to relieve the congestion in the system. FACTS devices can be strategically placed such that congestion cost is reduced, curtailment is decreased and price volatility due to congestion is minimized.

8.CONCLUSION

Today, FACTS devices are individually controlled. But according to a new EPRI report, inventive strategies incorporating system-wide control logic could further increase power transfer capability, stability and reliability of transmission systems. Controllers would be able to maximize available transfer capacity which maintaining dynamic stability and security, which could help accommodate even more electricity transactions. The all solid-state implementation of power-flow controllers will result in a significant reduction in equipment size and installation labour, dramatic improvements in operating flexibility and performance, and a progressive reduction in capital cost that is fuelled by advances in power semiconductor technology. Furthermore, the uniform, all solid-state approach is expected to reduce manufacturing cost and lead-time by allowing the use of standard, prefabricated power inverter modules in different applications. All these will hasten the broad application of the FACTS concepts and the achievement of its ultimate goal, the higher utilization of electric power systems.

REFERENCES

- [1] N. G. Hingorani and L. Gyugyi, “Understanding FACTS”, IEEE Press, 1999.
- [2] Y. H. Song and A. T. Johns, “Flexible C Transmission System (FACTS)”, IEE Power and Energy Series 30, 1999.
- [3] “FACTS Application”, IEEE Power

- Engineering Society, FACTS Application Task Force, 1998.
- [4] A. Sode-Yome and N. Mithulananthan, "Comparison of shunt capacitor, SVC and STATCOM in static voltage stability margin enhancement," International Journal of Electrical Engineering Education, UMIST, Vol. 41, No. 3, July 2004.
- [5] C. P. Gupta, S. C. Srivastava and R. K. Varma, "Enhancement of static voltage stability margin with reactive power dispatch using FACTS devices", 13th BSCG in Trondheim, June 28, July 2nd, 1999. Senior IEEE Transactions on Systems, Man, and Cybernetics, IEEE Controllers Power Engineering Society General Meeting, Denver, Colorado, 6-10 June 2004
- [5] <http://www.nationalgrid.com>, 2005
- [6] Y Xia, YH Song, CC Liu, YX Sun, "Available Transfer Capability Enhancement Using FACTS Devices", IEEE Trans. P. S, 2003
- [7] C. A. Canizares, A. Berizzi, P. Marannino, "Using FACTS Controllers to Maximize Available Transfer Capability", Bulk Power System Dynamics and Control IV Restructuring, August 24-28, 1998, Santorini, Greece.
- [8] P. Rao, ML Crow, Z Yang, "STATCOM Control for Power System Voltage Control Applications", IEEE Trans. Power Delivery, 2000.
- [9] JY Liu, YH Song, P Metha, "Strategies for Handling UPFC Constraints in Steady-State Power Flow and Voltage Control", IEEE Trans. Power System, 2000.
- [10] S.N. Singh, A.K. David, "Optimal Location of FACTS Devices for Congestion Management", Elsevier Science, Electric Power System Research 58 (2001) 71-79
- [11] K.S. Verma, S.N. Singh, H.O. Gupta, "Location of Unified Power Flow Controller for Congestion Management", Electric Power System Research 58 (2001) 89-96
- [12] M. Ching and D. Lam, "A Unified PSS, SVC and Power System Oscillations", IEEE Trans. PS Vol. 18, No. 2, pp. 786-792, May 2003.