



# Implementing digital system for temperature monitoring in food processing industry

T.Jayachandran<sup>1</sup>, S.Janaranjani<sup>2</sup>, R.Priya Ranjini<sup>3</sup>, M.Abbas Gori<sup>4</sup>, K.K.Dharani Dharan<sup>5</sup>,  
<sup>1</sup>Assistant professor, <sup>2,3,4,5</sup>UG Students

Department of Electronics and Communication, Nandha Engineering College, Erode-52,  
Tamil Nadu, India.

<sup>2</sup>janaranjaniecea2014@gmail.com, <sup>5</sup>kkdharanidharan@gmail.com

**Abstract**—Food processing is a long process with multiple stages. One of stages is drying. The food materials have to be dried in the dryer for preservation. Analog meter is used to monitor the temperature of the dryer. This is a time consuming operation. To overcome these issues, another approach is to install digital system close to the dryer. In this setup, temperature sensor is used to approximate the temperature in the dryer. Then the reliable information about the temperature is displayed using seven segment display unit. An additional step added to the system is to alert with GSM. These features are used to monitor the temperature of the dryer effectively by reducing time and energy. The monitoring of temperature is essential to maintain the standard of the product.

**Index Terms**—Dryers, PIC 16F877A, temperature monitoring, temperature sensor.

## I. INTRODUCTION

TEMPERATURE is a property which can change very quickly. TSo, we have to monitor it with much consciousness. Temperature monitoring is necessary in the food processing industry. The temperature of the dryer is to be monitored. The dryer is many meters high [1]. The dryer have high temperature. The people who monitor the temperature have to withstand to that hot conditions. It is a problem in terms of health and safety. Many sufferings such as fatigueness, eye irritations are reported.

The analog meters are used to indicate the temperature. But there is a necessity to develop the digital temperature monitoring system to fight with such warm environments and to control the thermal comfort in the dryer. It is a simple process of monitoring the temperature of the dryer in the food processing industry. The temperature in the dryer can be monitored using sensors, seven segment display unit and Global System for Mobile Communication (GSM). The problems are taken into account while designing the improved

temperature monitoring system. This study also makes aware about the health issues and tries to put forth some suggestions to repair those problems. This proposed paper supposed to solve the issues relating to monitoring of the temperature of the hot dryers.

This paper is organized as follows: Section II presents the

works related to the temperature monitoring, Section III explains the proposed approach, Section IV discusses the results obtained, and Section V reports conclusion.

## II. RELATED WORKS

Temperature monitoring is an essential part of any industrial process. In food processing, the temperature monitoring is required to determine whether materials have achieved the desired characteristics. Moreover, the temperature is an excellent indicator for early signs of malfunction [2]. Thus, it can be used to detect the excessive friction caused due to improper lubrication.

Temperature monitoring requires temperature sensor with high sensitivity and good accuracy. The temperature measurements can be used to characterizes the food material condition and as a damage indicator of the food material in the dryer [3]. Temperature is one of the most frequently measured physical quantities.

Temperature measurement provides information about the properties of a material. So its regulation and control are of vital importance in many industrial processes. Precise control over temperature measurement is particularly important when processing the materials. Many different methods have been developed for temperature measurement. Most of them can be classified into three categories: mechanical, electronic and infrared [2]. The specific features of each method make them more or less suitable for various types of applications.

### III. PROPOSED APPROACH

This proposed paper aims to reduce the discomfort of monitoring the temperature of the dryer by getting closer to it in the food processing industry. It focuses on displaying the temperature of the dryer in the display unit by obtaining input with the use of the temperature sensor.

The temperature of the dryer is indicated by using the analog meter. Analog meter is kept at the top of the dryer. Each and every time, a person has to step up in the ladder to monitor the temperature prevailing in the dryer. It is uncomfortable to monitor the reading as the temperature of the dryer is high around 150 degrees Celsius and also it is time consuming and energy consuming process.

The temperature in the dryer has to be monitored regularly. The food materials such as rice have to be dried in the dryer for preservation for long time. Else the food material gets spoiled. In order to prevent the damage occurring to the food material due to the higher temperature, the monitoring of temperature is essential one.

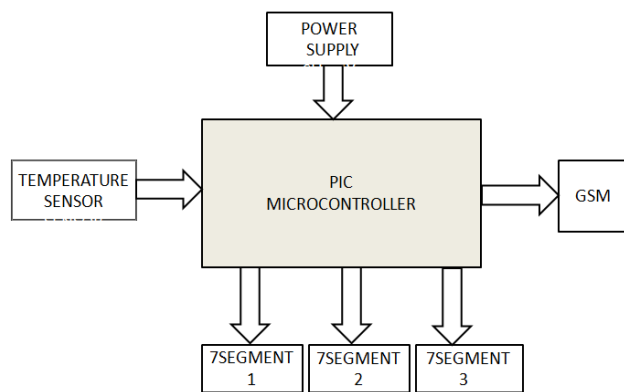

Figure: Block Diagram for Digital Temperature monitoring

The proposed model consists of a temperature sensor [4][5][6], three displays, PIC microcontroller and GSM, if required. The temperature sensor used is DS18B20. The microcontroller used is PIC 16F877A. The display used is seven segment displays. The power supply is required to energize the circuit. The power supply of about +12V are used. Arduino controller is not used here. It consists of only 14 pins. But we have to connect 24 pins of display.

Arduino can be used by integrating using IC. But the circuit becomes bigger. There are three displays. So three ICs should be used. In order to reduce the complexity and cost of the circuit, PIC microcontroller is used. Early models of PIC had Read - Only Memory (ROM) or Field Programmable EPROM for program storage, some with provision for erasing memory. All current models use flash memory for program storage and newer models allow the PIC to reprogram itself. Program memory and data memory are separated. Data memory is 8-bit, 16-bit and in latest model, 32-bit wide.

Program instructions vary in bit-count by family of PIC and may be 12, 14, 16, or 24 bytes long. The instruction set also varies by model, with more powerful chips adding instructions for digital signal processing functions. PIC microcontroller consists of three ports. Each port consists of 8 pins. So totally 24 pins are available to connect to inputs. Each display consists of 8 input pins and one common pin. So inputs from three ports of PIC microcontroller are connected to pins of three displays.

The hardware capabilities of PIC devices range from 6-pin SMD, 8-pin DIP chips with discrete I/O pins, ADC and DAC modules and communications ports such as UART, I2C, CAN and even USB. Low-power and High-speed variations exists for many types. PIC devices are popular with both industrial developers and hobbyists due to their low cost, wide availability, large user base, extensive collection of application notes, availability of low cost or free development tools, serial programming and re-programmable Flash-Memory capability.

These PIC 16 devices feature a 14-bit wide code memory and an improved 8-level deep call stack. The instruction set differs very little from the baseline devices, but the two additional opcode bits allow 128 registers and 2048 words of code to be directly addressed. There are a few additional miscellaneous instructions and two additional 8-bit literal instructions add and subtract. The mid-range core is available in the majority of devices labeled PIC12 and PIC16.

These PIC 16 units characteristic a 14-bit totally code memory also progressed 8-level profound bring stack. The direction book situated contrasts next to no from those benchmark devices, yet the two extra opcode odds permit 128 registers Furthermore 2048 expressions from claiming code to make straightforwardly tended to. There would a couple extra incidental guidelines Furthermore two extra 8-bit strict instructions, include Furthermore subtract. Those mid-range centers will be accessible in the dominant part from claiming gadgets named PIC12 Also PIC16.

The display used is seven segment display of 4 inch. There are two types of seven segment displays which are common cathode and common anode. Any of these two displays can be used according to the use. For common cathode display the common pin is grounded and for common anode display, the common pin is given to the supply. Multiple-digit LED displays as used in pocket calculators and similar devices used multiplexed displays to reduce the number of I/O pins required to control the display.

For example, all the anodes of the A segments of each digit position would be connected together and to a driver circuit pin, while the cathodes of all segments for each digit would be connected. To operate any particular segment of any digit, the controlling integrated circuit would turn on the cathode driver for the selected digit, and the anode drivers for the desired segments; then after a short blanking interval the next digit would be selected and new segments lit, in a sequential fashion. In this manner an eight digit display with seven segments and a decimal point would require only 8

cathode drivers and 8 anode drivers, instead of sixty-four drivers and IC pins. Often in pocket calculators the digit drive lines would be used to scan the keyboard as well, providing further savings; however, pressing multiple keys at once would produce odd results on the multiplexed display.

Seven segment displays is chosen, because it uses low power for its operation less than 2.5V. It resists up to 2.5V. To operate in voltage more than that 220 ohm or 330 ohm resistors can be used. Any color display can be used such as Red, Yellow or Green. Seven segment displays comes under different sizes such as 7.6 mm, 10 mm, 14.2 mm, etc. According to the need, the size of the display is chosen. 4 inch display is chosen for comfortable monitoring of temperature in the dryer.

A seven-segment indicator is a form of electronic display device for displaying decimal numerals that is an alternative to the more complex dot matrix displays. Seven-segment displays are widely used in digital clocks, electronic meters, basic calculators, and other electronic devices that display numerical information. The seven segments are arranged as a rectangle of two vertical segments on each side with one horizontal segment on the top, middle, and bottom. Additionally, the seventh segment bisects the rectangle horizontally.

There are fourteen-segment displays and sixteen segment displays. However, these have mostly been replaced by dot matrix displays. Twenty-two segment the displays are capable of displaying the full ASCII character set were briefly available in the early 1980s, but did not prove popular. The segments of a 7-segment display are referred to by the letters A to G, where the optional decimal point (an "eighth segment", referred to as DP) is used for the display of non-integer numbers.

LM35 temperature sensor provides output of 10 mill volt per degree Celsius, with an accuracy of 0.5 degree Celsius at 25 degree Celsius. The operating range is -55 degree Celsius to +150 degree Celsius. But DS18B20 is mostly preferred. Though both the sensors have the required operating range, the latter have very high sensitivity. It senses the temperature more sensibly than LM35. It can sense even the small change in temperature [7][8][9].

A Buzzer or a beeper is an audio signaling device which may be mechanical, electromechanical or piezoelectric. Typical uses of buzzer and beeper include alarm devices, timers, user input such as a mouse click or a key stroke. It is an electrical device which is used to make a buzzing sound. For example, to attract someone's attention. It is a mechanical, electromechanical, magnetic, electromagnetic, electro-acoustic or piezoelectric audio signaling device. A piezo electric buzzer can be driven by an oscillating electronic circuit or other audio signal source. A click, beep or ring can indicate that a button has been pressed.

DS18B20 have operating range of -67 degree Fahrenheit to

+25 degree Fahrenheit. This digital thermometer provides 9-bit to 12-bit Celsius temperature measurements and has an alarm function with non-volatile user-programmable upper and lower trigger points. Also it derives power directly from the data line and eliminating the need for the external power supply. Thus it requires only one data line and ground to communicate with a microcontroller. And it is also a water proof. So it is highly preferred than any other temperature sensors [10][11][12].

In food processing industry, GSM is used as an alarm for the person to know whether the temperature is increasing or showing normal in digital of seven-segment display. If there is any requirement, GSM can be used for more comfortability. GSM is an open, digital cellular technology used for transmitting the mobile voice and the data services. Since three seven segment displays are used, the temperature of upto 999 degree Celsius can be displayed. Each display individually displays one digit. So, three displays are linearly arranged to display the three digit temperature. A Buzzer is used to indicate the abnormal temperature range.

GSM networks operate in a number of different carrier frequency ranges (separated into GSM frequency ranges for 2G and UMTS frequency bands for 3G), with most 2G GSM networks operating in the 900 MHz or 1800 MHz bands. Where these bands were already allocated, the 850 MHz and 1900 MHz bands were used instead (for example in Canada and the United States). In rare cases the 400 and 450 MHz frequency bands are assigned in some countries because they were previously used for first-generation systems. For comparison, most 3G networks in Europe operate in the 2100 MHz frequency band.

Regardless of the frequency selected by an operator, it is divided into timeslots for individual phones. This allows eight full-rate or sixteen half-rate speech channels per radio frequency. These eight radio timeslots (or burst periods) are grouped into a TDMA frame. Half-rate channels use alternate frames in the same timeslot. The channel data rate for all 8 channels is 270.833 kbit/s, and the frame duration is 4.615 ms. The transmission power in the handset is limited to a maximum of 2 watts in GSM 850/900 and 1 watt in GSM 1800/1900.

GSM has used a variety of voice codecs to squeeze 3.1 kHz audio into between 6.5 and 13 kbit/s. Originally, two codecs named after the types of data channel they were allocated were used called Half Rate (6.5 kbit/s) and Full Rate (13 kbit/s). These used a system based on linear predictive coding (LPC). In addition to being efficient with bitrates, these codecs also made it easier to identify more important parts of the audio, allowing the air interface layer to prioritize and better protect these parts of the signal. GSM was further enhanced in 1997 with the enhanced full rate (EFR) codec, a 12.2 kbit/s codec that uses a full-rate channel. Finally, with the development of UMTS, EFR was refactored into a variable-rate codec called AMR-Narrowband.

Sometimes mobile network operators restrict handsets that they sell for use with their own network. This is called locking and is implemented by a software feature of the phone. A subscriber may usually contact the provider to remove the lock for a fee, utilize private services to remove the lock, or use software and websites to unlock the handset themselves. It is possible to hack past a phone locked by a network operator.

GSM was intended to be a secure wireless system. It has considered the user authentication using a pre-shared key and challenge-response, and over-the-air encryption. However, GSM is vulnerable to different types of attack, each of them aimed at a different part of the network. GSM uses several cryptographic algorithms for security. The A5/1, A5/2, and A5/3 stream ciphers are used for ensuring over-the-air voice privacy. A5/1 was developed first and is a stronger algorithm used within Europe and the United States; A5/2 is weaker and used in other countries. Serious weaknesses have been found in both algorithms: it is possible to break A5/2 in real-time with a ciphertext-only attack, and in January 2007, The Hacker's Choice started the A5/1 cracking project with plans to use FPGAs that allow A5/1 to be broken with a rainbow table attack. The system supports multiple algorithms so operators may replace that cipher with a stronger one.

GSM uses General Packet Radio Service (GPRS) for data transmissions like browsing the web. The most commonly deployed GPRS ciphers were publicly broken in 2011. The researchers revealed flaws in the commonly used GEA/1 and GEA/2 ciphers and published the open-source "gprsdecode" software for sniffing GPRS networks. They also noted that some carriers do not encrypt the data (i.e., using GEA/0) in order to detect the use of traffic or protocols they do not like (e.g., Skype), leaving customers unprotected. GEA/3 seems to remain relatively hard to break and is said to be in use on some more modern networks. If used with USIM to prevent connections to fake base stations and downgrade attacks, users will be protected in the medium term, though migration to 128-bit GEA/4 is still recommended.

The temperature existing in the dryer is around 150 degree Celsius. After completing several stages in food processing, the food material reaches the dryer for drying. It is used to remove the moisture content from the food material. So that the food material can be preserved for a long time. The temperature in the dryer has to be maintained. Else the food material gets damaged due to overheating. So the temperature in the dryer has to be monitored properly.

The temperature of the dryer has to be sensed with the help of temperature sensor possessing good sensitivity [13][14]. The sensor output is provided to the PIC microcontroller. The input pins of each display are connected to the three pots of PIC microcontroller. The sensed temperature is displayed in the display unit with the help of PIC microcontroller and transistors. The transistors are used to boost the signals from the PIC microcontroller and give it to the displays. If the temperature of the dryer changes, the temperature displayed in

the seven segments display also changes accordingly. If the temperature is above 150 degree Celsius, it is indicated with the help of buzzer. So the abnormal increase of the temperature in the dryer can be brought under control.

The proposed method consists of seven segment displays which are three in number, to view the temperature away from the dryer. Also the message about the level of temperature in the dryer is sent to the mobile phone of concerned person by the assistance of GSM. This minimizes the strain of viewing the temperature in analog meter. It also brings down the time consumed for monitoring purpose. It is an easier and quicker process of monitoring the temperature of the dryer.

Thus the monitoring of the temperature ensures that the temperature of the dryer is in the acceptable level only. Moreover, the monitoring of the temperature is used to detect whether the food materials are dried safely and without existing in the risk zone due to excessive temperature. Therefore, the temperature monitoring prevents damage to industrial facility and human lives.

#### IV. SIMULATION AND RESULTS

Simulation of the implementation of digital system for temperature monitoring in food processing industry is done with the help of Proteus and CCS Compiler. Proteus is software for microprocessor simulation, schematic capture, and printed circuit board (PCB) design. It is developed by Lab center Electronics. PROTUES combines advanced schematic capture, mixed mode SPICE simulation, PCB layout and auto routing to make a complete electronic design system. The PROTUES product range also includes our revolutionary VSM technologies, which allow you to simulate micro-controller based design, complete with all the surrounding electronics.

The PCB Layout module is automatically given connectivity information in the form of a net list from the schematic capture module. It applies this information, together with the user specified design rules and various design automation tools, to assist with error free board design. PCB's of up to 16 copper layers can be produced with design size limited by product configuration. The micro-controller simulation in Proteus works by applying either a hex file or a debug file to the microcontroller part on the schematic. It is then co-simulated along with any analog and digital electronics connected to it. This enables its use in a broad spectrum of project prototyping in areas such as motor control, temperature control and user interface design. It also finds use in the general hobbyist community and, since no hardware is required, is convenient to use as training or teaching tool.

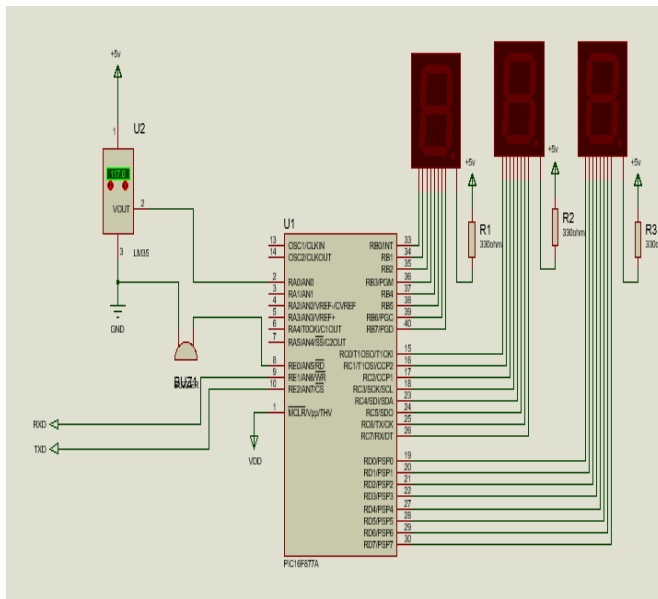

Figure: Circuit Diagram of Digital Temperature Monitoring

Code Composer Studio (CCS) is an integrated development environment to develop applications for the embedded processors. The embedded processors of The Texas Instruments include TMS320 DSPs, OMAP system on-a-chip, Hercules microcontrollers, Simple link MCUs, MSP430 and Tiva/Stellaris microcontrollers. It also enables debugging on several subsystems such as Ducati, IVA Accelerator and PRU-ICSS. Code Composer Studio is primarily designed as for embedded project design and low-level JTAG based debugging. However, the latest releases are based on unmodified versions of the Eclipse open source IDE, which can be easily extended to include support for OS level application debug and open source compiler suites such as GCC. Early versions included a real time kernel called DSP/BIOS and its later inception SYS/BIOS. Currently, the successor to these tools, the TI-RTOS embedded tools ecosystem, is available for downloading as a free plug-in to Code Composer Studio.

Difficulty in monitoring the temperature at higher levels in dryer is a major issue. In this regard, digital system based temperature monitoring system with GSM is developed. Seven segment display modules are implemented successfully. GSM module is used for transmitting the real time temperature data to the responsible person. Developed system is capable of monitoring the temperature by not getting so closer to the dryer. The temperature existing inside the dryer is displayed on the seven segment display unit using temperature sensor. The digital system for temperature monitoring of dryer in the food processing industry is implemented successfully and they assure that the desired accuracy is sustained for a long period. The developed system is of low cost, and an energy efficient one. Also, it is easy to operate with utmost accuracy.

## V. CONCLUSION

This work proposes an improved monitoring system for temperature in a dryer. Monitoring of temperature is of vital importance. Since uneven temperature in dryer leads to spoilage of food material. This work is specifically applied to food material like rice but is not restricted to this scenario. The proposed system includes a sensor at the top of the dryer for transforming the physical quantity, temperature into the display unit via PIC microcontroller. Therefore, reliable temperature information is displayed on seven segment displays.

This also minimizes the complexity of the monitoring of temperature with enhanced accuracy. The monitoring system is greatly simplified. The proposed system provides consistent information about temperature. The monitoring of temperature is significant for product quality. Thus the proposed method is to detect the abnormal range of temperature and indicate it for regulating the processing of drying. The future work involves remote monitoring of temperature and further improvement can be made using advanced technologies.

## REFERENCES

- [1] Abhishek Singh, yadvindra pandey, Ashok kumar, Manoj kumar Singh, Anuj kumar and Subhas Chandra Mukhopadhyay, "Ventilation Monitoring and Control System For High Rise Historical Building", *IEEE Sensor Journal*, vol.17, No.22, Nov.2017
- [2] Ruben Usamentiaga, Julio Molleda, Daniel Garcia, Juan C. Granda and Jose Luis Rendueless, "Temperature Measurement of Molten Pig Iron with Slag Characterization and Detection using Infrared Computer vision", *IEEE trans.*, vol.61, No.5, May 2012.
- [3] Ruben Usamentiaga, Daniel F. Garcia, Julio Mollenda Franciso G. Bulnes and Jesus M. Perez, "Temperature Measurement Using the Wedge Method: Comparison and Application to Emissivity Estimation and Compensation", *IEEE trans.*, vol.60, No.5, May 2011.
- [4] J. Lim, Q. Yang, B. E. Jones, and P. R. Jackson, "Strain and temperature sensors using multimode optical fiber Bragg gratings and correlation signal processing," *IEEE trans.*, vol. 51, no. 4, pp. 622–627, Aug. 2002.
- [5] G. Wang, A. Heidari, K. A. A. Makinwa, and G. C. M. Meijer, "An accurate BJT-based CMOS temperature sensor with duty-cycle modulated output," *IEEE trans.*, vol. 64, no. 2, pp. 1572–1580, Feb. 2017.
- [6] A. Vaz *et al.*, "Full passive UHF tag with a temperature sensor suitable For human body temperature monitoring," *IEEE trans.*, vol. 57, no. 2, pp. 95–99, Feb. 2010.
- [7] L. C. Yu, G. T. Dunne, K. S. Matocha, K. P. Cheung, J. S. Suehle, and K. Sheng, "Reliability issues of SiC MOSEFTs: A technology for high-Temperature environments," *IEEE trans.*, vol.10, no.4, pp.418–426, Dec 2010.

- [8] K. Sheng, "Maximum junction temperatures of SiC power devices," *IEEE trans.*, vol. 56, no. 2, pp. 337–342, Feb. 2009.
- [9] P. Ning, F. Wang, and K. D. Ngo, "High-Temperature SiC power module electrical evaluation procedure," *IEEE trans.*, vol. 26, no. 11, pp. 3079–3083, Nov. 2011.
- [10] J. Lim, Q. Yang, B. E. Jones, and P. R. Jackson, "Strain and temperature sensors using multimode optical fiber Bragg gratings and correlation signal processing," *IEEE trans.*, vol. 51, no. 4, pp. 622–627, Aug. 2002.
- [11] G. Wang, A. Heidari, K. A. A. Makinwa, and G. C. M. Meijer, "An accurate BJT-based CMOS temperature sensor with duty-cycle modulated output," *IEEE trans.*, vol. 64, no. 2, pp. 1572–1580, Feb. 2017.
- [12] A. Vaz *et al.*, "Full passive UHF tag with a temperature sensor suitable For human body temperature monitoring," *IEEE trans.*, vol. 57, no. 2, pp. 95–99, Feb. 2010.
- [13] L. C. Yu, G. T. Dunne, K. S. Matocha, K. P. Cheung, J. S. Suehle, and K. Sheng, "Reliability issues of SiC MOSEFTs: A technology for high-Temperature environments," *IEEE trans.*, vol. 10, no. 4, pp. 418–426, Dec 2010.
- [14] K. Sheng, "Maximum junction temperatures of SiC power devices," *IEEE trans.*, vol. 56, no. 2, pp. 337–342, Feb. 2009.
- [15] P. Ning, F. Wang, and K. D. Ngo, "High-Temperature SiC power module electrical evaluation procedure," *IEEE trans.*, vol. 26, no. 11, pp. 3079–3083, Nov. 2011.
- [16] P. Ning, F. Wang, and K. D. Ngo, "High-Temperature SiC power module electrical evaluation procedure," *IEEE trans.*, vol. 26, no. 11, pp. 3079–3083, Nov. 2011.
- [17] J. Lim, Q. Yang, B. E. Jones, and P. R. Jackson, "Strain and temperature sensors using multimode optical fiber Bragg gratings and correlation signal processing," *IEEE trans.*, vol. 51, no. 4, pp. 622–627, Aug. 2002.