



Automatic river water quality monitoring using embedded system

¹Murugasami.R, ²Monisha.M, ³Prathip kumar.P, ⁴Ravisankar.R, ⁵Prakash.M

¹Associate Professor, Department of Electronics and Communication Engineering

²³⁴⁵Students of Electronics and Communication Engineering, Nandha Engineering College

(Autonomous), Erode.

Email:¹murugasami.r@gmail.com,²monisha25696@gmail.com

Abstract-Water is an important natural resource which needs constant quality monitoring for ensuring its safe use. This project presents the application for Real Time River Water quality monitoring. Water quality monitoring system composed of number of sensor nodes with networking capability which are deployed at different places in the river root. Each sensor node consists of microcontroller, GSM module and water quality sensors. The sensor probes shall continuously measure the different water quality parameters like pH, Temperature, turbidity and Conductivity. The parameters are measured in real time by the sensors and send the data to the data center using wireless data transfer protocol. The proposed system is used to detect the contamination in water due to industrial and society wastes, identifying the changes in water quality in a real time manner and prevent the river water from pollution.

Keywords-Conductivity sensor, PHsensor, Turbidity Sensor, TemperatureSensor, GSM Module.

I. INTRODUCTION

Water Pollution is a major global problem which requires ongoing valuation and modification of water resource guiding principle at the levels of international down to individual wells. India is a country in which many of the rivers are considered to be sacred but water pollution in India has greatly affected the sanctity of these rivers. Apart from that, the contamination of the water bodies has reached such a level which has made many of the rivers too undesirable to use. Many rivers have been deemed to be unsafe for human consumption and this leads to water scarcity. It has been

predictable that water pollution is the most important worldwide cause of deaths and diseases and it accounts for the deaths of more than 14,000. Water pollution in India affects the children more rigorously than any other group of people. About one million children under the age of five die every year from diarrhea in India as a direct result of water related diseases. So there need to be a constant check on the pollution of various water bodies in order to control them. All these facts insist the need for constantly monitoring the water quality of the various water bodies so that it helps in evaluate the amount of pollution control needed. Water quality monitoring also helps in characterizing and identifying the changes in water quality over time. Traditionally, the water quality detection has been carried out manually wherein the water samples are collected and taken to the laboratories for analysis. Since these methods fail to deliver real time data, we propose a system which can sense the water quality parameter continuously and send the data real time to the monitoring station using wireless technology.

II. EXISTING SYSTEM

In favor of resolving the problem of the manual analytical method adopted in water quality detection with lack of real-time data, a novel type of Remote Water Quality Measuring and Monitoring System based on WSN is introduced. The disadvantages of this existing system are that; there is no continuous and remote monitoring, human resource is required, less reliable, no monitoring at the source

of waters i.e. no on field monitoring and the frequency of testing is very low. In the existing system water contaminant parameters was found using chemical testing or laboratory testing equipment. The existing method also consists of manual system with tedious process and it is very time consuming. Due to these disadvantages of the existing system it is required to develop a system that will allow real time and continuous monitoring of water quality. Thus various advanced technologies for monitoring water quality have been proposed in the recent years. The proposed system uses different sensors like water-temperature, turbidity, Conductivity and pH. The system uses GSM communication to meet the low power requirements of the exploitation scenario. This project is simple, field deployable sensor for long-term monitoring of water quality levels in River water. Data collected by sensor and sent via gsm module at control of 2.4 GHz . A water quality measurement system based on thick-film technology multisensory and which is used for sensing pH, temperature, luminance and turbidity.

III. PROPOSED STSTEM ARCHITECTURE

The proposed system senses the water quality parameters such as PH, temperature, Conductivityand turbidity. It continuously sends the data real time to the monitoring station. It is simple and more efficient. Data collected by sensor and sent via gsm module at control of 2.4 GHz. Thus each monitoring area forms a cluster comprising of several wireless sensor nodes responsible for sensing, data collection & processing and communication. Each sensor node can contain the sensors for monitoring the basic water quality parameters like pH, temperature, Luminance, turbidity, and Conductivity.

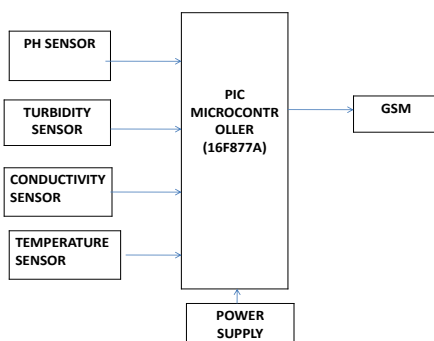

Proposed system Block Diagram

The parameters will be sensed continuously and the data will be send real time to the (base station) using GSM communication. Since the nodes are deployed in an outdoor environment, the transmission range of the GSM can go up to Long range. The PIC microcontroller is used as a core controller. To measure water parameters such as pH, turbidity, Conductivity and temperature at remote place. To collect data from various sensor nodes and send it to base station by wireless channel. The data from controller send to receiver using GSM communication. To send SMS to an authorized person automatically when water quality detected does not match the preset standards, so that, necessary actions can be taken.

IV.DESIGN OF WIRELESS SENSOR NODE

A Wireless Sensor Network is comprised of wireless sensor nodes which are the central elements in the network consisting of the sensing module, processing module, communication module and power module

A.SENSING MODULE

PH SENSOR:

Acidity and the alkaline property of any solution are measured using the pH values. This is a basic parameter which needs to identify the quality of the water. Electrode based sensor technologies use Nernst equation to obtain the measurement of pH. In common, an indicator electrode and a reference electrode are immersed in a solution aid to develop a potential difference due to the availability of anions and cations, which is used for estimating pH. Difference between the voltage developed in the indicator electrode (E_{ind}) and the voltage developed in the reference electrode (E_{ref}) are taken as the measured voltage (E).

$$E = E_{ind} - E_{ref} \quad (1)$$

$$E = ET' - \left(\frac{R'}{f} \right) \ln(aH) \quad (2)$$

The temperature of the solution directly affects the pH value, therefore Nernst equation states that the temperature. dependent constant (ET'), Gas Constant (R'), absolute temperature (K) and Faraday's constant (F) are related to the measured voltage and the logarithmic of this activity.

Conductivity Sensor

Conductivity measured either by applying an alternating current (AC) to two electrodes immersed in a solution and

measuring the resulting voltage or applying an AC voltage to the two electrodes in the solution and measuring the resultant current. Mathematical model of conductivity based on ohm's law where, Conductance (G) is reciprocal of the resistance(R).

$$R = VI = 1 \quad (3)$$

$$\text{Conductivity} = \text{cellconstant} \times \text{condu} \quad (4)$$

Cell constant (Kcell) depends on length between the two electrodes (l) and the surface area of the electrode (A).

$$K_{\text{cell}} = (5)$$

Temperature correction and cable correction are the influencing factors that relate to an accurate measurement in detection of conductivity range. Temperature correction is required to obtain an accurate reading as the temperature is proportional to the conductivity. In addition cable resistance affects the measurements of high conductivity solutions while cable capacitance influences measuring low conductivity solutions. This sensor is used to measure the level of conductivity in water.

Turbidity sensor

Turbidity is a measure of the cloudiness of water. Turbidity has indicated the degree at which the water loses its transparency. It is considered as a good measure of the quality of water. Turbidity blocks out the light needed by submerged aquatic vegetation. It also can raise surface water temperatures above normal because suspended particles near the surface facilitate the absorption of heat from sunlight.

LM35 sensor

LM35 is a precision IC temperature sensor with its output proportional to the temperature (in °C). in this sensor used in this project to measure the temperature level in water. The sensor circuitry is sealed and therefore it is not subjected to oxidation and other processes. With LM35, temperature can be measured more accurately than with a thermistor. It also possess low self heating and does not cause more than 0.1 °C temperature rise in still air.

B.PROCESSING MODULE

The main function of this module is to process execute the instructions relating to sensing, data transmission, etc. For the purpose of processing, the PIC microcontroller PIC16F877 is used in our system as it has low cost, compact size and low power consumption. Also it provides more programming flexibility compared to others. Normally the output from the sensors will be an analog signal having a continuous magnitude as a function of time. So this analog signal need to be digitized for the purpose of processing and therefore, an analog-to-digital converter is required. Some sensors have integrated ADC in them; otherwise we have to incorporate an ADC module in the circuit design. In our system, since there is no integrated ADC with the pH sensor, the A/D conversion is performed by the PIC processor with a 10 bit resolution. Use of PIC16F877 for processing removes the need for an additional ADC module as this PIC has an inbuilt ADC and this in turn reduces the cost and power requirement. The 10 bit digital values from the ADC are then converted to the corresponding pH after the necessary computations. The pH value is now serially sent using the UART interface RS232 to the communication module for transmission

C.COMMUNICATION MODULE

GSM

A GSM network is composed of several functional entities, whose functions and interfaces are specified. The GSM network can be divided into three broad parts. The Mobile Station is carried by the subscriber. The Base Station Subsystem controls the radio link with the Mobile Station. The Network Subsystem, the main part of which is the Mobile services Switching Center (MSC), performs the switching of calls between the mobile users, and between mobile and fixed network users. The MSC also handles the mobility management operations. Not shown is the Operations and Maintenance Center, which oversees the proper operation and setup of the network. The Mobile Station and the Base Station Subsystem communicate across the Um interface, also known as the air interface or radio link. The Base Station Subsystem communicates with the Mobile services Switching Center across the A interface.

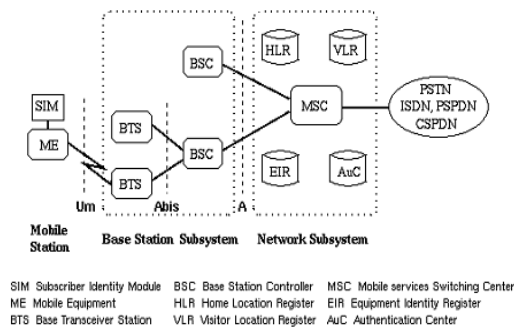

D. POWER REQUIREMENT FOR THE PROTOTYPE

Laboratory equipments use AC power and it is conversion to DC facilitated by the power supply units embedded inside the instruments while, operations of field operated devices utilize battery power. In this project use a 12v transformer The transformer that is used in power supply is step-down transformer, which *steps down* the input AC voltage. The magnitude by which transformer steps down the voltage depends on the turn's ratio of primary and secondary winding.

V. CONCLUSION AND FUTURE WORK

In this paper, we present the system architecture for a Wireless sensor Network which aids in River Water Quality Monitoring. This paper also proposes a novel technique for detecting the contamination in water due to industrial and society wastes, identifying the changes in water quality in a real time manner and prevents the river water from pollution. The proposed design of the sensor node consists of the various sensors like temperature sensor, luminance sensor, PH sensor and turbidity sensor which is implemented using PIC microcontroller and the wireless communication module consisting of GSM. Methods to improve and optimize the system performance and reliability of the current system will also be taken up as the future work. In future we use IOT concept in this project Detecting the more parameters for most secure purpose and Increase the parameters by addition of multiple sensors .By interfacing relay we controls the supply of water.

VI. RESULT AND DISCUSSION

In this project we can monitor the water quality parameters using GSM. PIC microcontroller send the value to the authority via SMS by using GSM. The GSM based

monitoring is quite useful compared to manual monitoring and also it is reliable. The time for receiving messages may vary due to the public GSM network traffic but still then it is effective than manual monitoring.

REFERENCES:

- [1] R. Chandrajith, C. Dissanayake, T. Ariyaratna, H. Herath, and J. Padmasiri, "Dose-dependent Na and Ca in fluoride-rich drinking water —Another major cause of chronic renal failure in tropical arid regions," *Science of The Total Environment*, vol. 409, no. 4, pp. 671–675, 2011.
- [2] N de Silva et al. (2013). Chronic Kidney Disease of unknown etiology (CKDu) and Arsenic poisoning due to Illegal pesticides [Online] Available: http://dSPACE.costi.gov.lk:8080/xmlui/bitstream/handle/123456789/148/Arsenic_and_CKDu.pdf?sequence=1
- [3] S.K Gunatilake et al., Chronic Kidney Disease (CKD) in Sri Lanka - Current Research Evidence Justification: A Review, *Sabaragamuwa University Journal*, vol. 13, no. 2, pp. 31-58, May, 2015
- [4] J.H Redman et al., Additional perspectives on chronic kidney disease of unknown aetiology (CKDu) in Sri Lanka – lessons learned from the WHO CKDu population prevalence study, *BMC Nephrology*, Vol. 15, no. 125, Jul. 2014
- [5] M.W.C Dharmawardaha et al. (2014). Chronic Kidney Disease of Unknown aetiology and ground-water ionicity; study based on Sri Lanka, *Environmental Geochemistry and Health*.
- [6] C Jayasumana et al. (2015) Drinking well water and occupational exposure to herbicides is associated with chronic kidney disease, in Padavi-Siripura, Sri Lanka, *Environmental Health BioMed Central*, [Online]. Available at: <http://www.ehjournal.net/content/14/1/6>.
- [7] J.M.R.S Bandara et al., Chronic renal failure among farm families in cascade irrigation systems in Sri Lanka associated with elevated dietary cadmium levels in rice and fresh water fish (Tilapia), *Environ Geochem Health*, vol.30, no. 5, pp. 465 -478, Oct. 2008
- [8] O.A Ileperuma et al., Dissolution of aluminium from sub-standard utensils under high fluoride stress: a possible risk factor for chronic renal failure in the North-Central Province, *J.Natn.Sci.Foundation Sri Lanka*, vol. 37, no. 3, pp. 219-222, Jul. 2009

- [9] APHA, (2005). Standard methods for the Examinations of Water and Wastewater, 2st ed. American Public Health Association, Washington, D.C. Journal of Engineering Technology, vol. 2, no. 2, pp. 1 -11, Sep. 2016.
- [10] V Sunitha and B Muralidhara Reddy, Determination of Fluoride Concentration in ground Water by Ion Selective electrode, Int.J.Curr.Res.Aca.Rev., vol. 2, no. 8, pp. 159-166, Aug. 2014.
- [11] C. S Wu, and J Ruzicka, Micro sequential injection: environmental monitoring of nitrogen and phosohate in water using a “Lab-on-valve” system furnished with microcolumn, Analyst, vol. 126, no. 11, pp. 1947- 1952, Nov. 2001.
- [12] K Vahal et al., Rapid Atomic Determination of Clacium and Magnesium in Aqueous Solutions by FIA using Potentiometric Detection, Electroanalysis, vol. 22, no. 19, pp. 2172 – 2178, Oct. 2010.
- [13] T.L Marques & N.M.M Coelho, Proposed flow system for spectrophotometric determination of fluoride in natural waters, Talanta, vol. 105, pp.69-74, Feb. 2013.
- [14] W Gong et al., A simple, Low-Cost Doble Beam Spectrophotometer for Colorimetric Detection of Nitrite in Seawater, IEEE Sensors Journal, 2009, vol. 9, No. 7, pp. 862 -869
- [15] Eric A. Kaltenbacher et al., Design and Applications of a Chemical Sensor Compatible with Autonomous Ocean-Sampling Networks, IEEE J. Ocean. Eng., vol. 26, no. 4, pp. 667 – 670, Oct. 2001
- [16] S Li and A Pandharipande, LED-Based Color Sensing and Control, IEEE Sensors journal, 2015, vol. 15, no. 11, pp. 6116-6124
- [17] T.Bhattacharjee et al. Sensor Design for Water Hardness Detection, in IEEE Sensors J. 2013© IEEE. doi: 10.1109/ICSENS.2013.6688443
- [18] R.V Raj. and H Pasqual Cost Effective Fluoride level Detector for Well Water, JET-OUSL, vol 2, pp. 43-50, Dec. 2014.
- [19] S.A.D.A.N Dissanayake et al. Colorimetric Sensor to Detect Fluoride Concentration of Drinking Water Sources, 110th Annual Sessions Of IESL, pp. 149 - 154, Oct. 2016
- [20] S.A.D.A.N Dissanayake et al., Optical sensor to detect titration end point to evaluate hardness of drinking water,