



## Multimode wireless broadcasting system using NRF

N.Manikandrababu<sup>1</sup>, K.Karthikeyan<sup>2</sup>, B.Maheswari<sup>3</sup>, S.Nandhakumar<sup>4</sup>, C.Poovizhi<sup>5</sup>.

<sup>1</sup>Assistant professor, Department of Electronics and Communication Engineering,

<sup>2,3,4,5</sup>UG Students, Department of Electronics and Communication Engineering,

Nandha Engineering College(Autonomous), Erode-52, Tamil Nadu, India

<sup>1</sup>manikandrababube@gmail.com,

<sup>2</sup>karthikkeyan002@gmail.com, <sup>3</sup>mahes96.boopathi@gmail.com, <sup>4</sup>nandhukvvs@gmail.com, <sup>5</sup>poovizhick@gmail.com.

### II. GENERAL WORKING OF INDUSTRY

**Abstract ---** In textile industries, the problem is that there is less gain of product due to lack of interest of the workers because of the continuity of the same work. In order to achieve the maximum gain in a shortest period as well as creating interest among the workers, Design of multimode wireless broadcasting system using NRF is proposed. In textile industries, the progress of work completion should be intimated to the workers to complete the assignment in time. Hourly targets are fixed to different teams to complete the work orders. In practical, some microphone based announcement systems are followed to intimate the progress to the workers and some companies follows the chalk and board procedures. Here we proposes a multi-node wireless broadcast system using radio frequency of range 2.4 GHz. In this system, an admin will enter the hourly target in a personnel computer. The proposed wireless system will works for the distance of 1200 meters in line of sight and 500-600 meters in off sight. The wireless device will act as a transceiver and in the receiver node, there will be a LCD/LED monitor to display the targets. For the purpose of compaction, maintenance free and for low power consumption, the LCD/LED is proposed here. Each and every nodes are assigned with different addresses, by the way the admin may easily sent the different data to different nodes.

### I. INTRODUCTION

#### 1.1 COMPANY PROFILE

Our project multimode wireless broadcasting system has been done in industry. the company has the main function of stitching the clothes. Here the workers has to complete their daily target with in 10 hrs.

#### 1.2 TEXTILE INDUSTRY

The industry is located at Tirupur district in Tamilnadu. It has twelve units, each unit can produce different cloth types.

Working of the industry is to stitching of clothes like towels, inner wears and child clothes. The company consist of

twelve sections. In each section 10 members are working in different stitching machines.

Twelve sections are :

- ❖ Spinning
- ❖ Weaving
- ❖ Fabric
- ❖ Cutting
- ❖ Sewing
- ❖ Finishing
  - Ironing
  - Packing

#### 2.1 SPINNING

Spinning is the twisting together of drawn-out strands of fibers to form yarn, and is a major part of the textile industry. The yarn is then used to create textiles, which are then used to make clothing and many other products. There are several industrial processes available to spin yarn, as well as hand-spinning techniques where the fiber is drawn out, twisted, and wound onto a bobbin.

#### 2.2 WEAVING

Weaving is a method of textile production in which two distinct sets of yarns or threads are interlaced at right angles to form a fabric or cloth. Other methods are knitting, crocheting, felting, and braiding or plaiting. The longitudinal threads are called the warp and the lateral threads are the weft or filling. (Weft or 'warrrior' is an old English word meaning "that which

is woven".[a]) The method in which these threads are inter-woven affects the characteristics of the cloth. Cloth is usually woven on a loom, a device that holds the warp threads in place while filling threads are woven through them. A fabric band which meets this definition of cloth (warp threads with a weft thread winding between) can also be made using other methods, including tablet weaving, back-strap, or other techniques without looms.

### 2.3 FABRIC

The primary source of dye, historically, has generally been nature, with the dyes being extracted from animals or plants. Since the mid-19th century, however, humans have produced artificial dyes to achieve a broader range of colors and to render the dyes more stable to resist washing and general use. Different classes of dyes are used for different types of fiber and at different stages of the textile production process, from loose fibers through yarn and cloth to complete garments.

Acrylic fibers are dyed with basic dyes, while nylon and protein fibers such as wool and silk are dyed with acid dyes, and polyester yarn is dyed with disperse dyes. Cotton is dyed with a range of dye types, including vat dyes, and modern synthetic reactive and direct dyes.

### 2.4 CUTTING

Cutting is the process which cut out the pattern pieces from specified fabric for making garments. Using the markers made from graded patterns and in accordance with the issue plan, fabrics are cut to prepare garment assembly. This is the major operation of the cutting room, of all of the operations in the cutting room this is the most decisive, because once the fabric has been cut, very little can be done to rectify serious mistakes.

### 2.5 SEWING

Process Flow Chart for Garments Sewing Department:

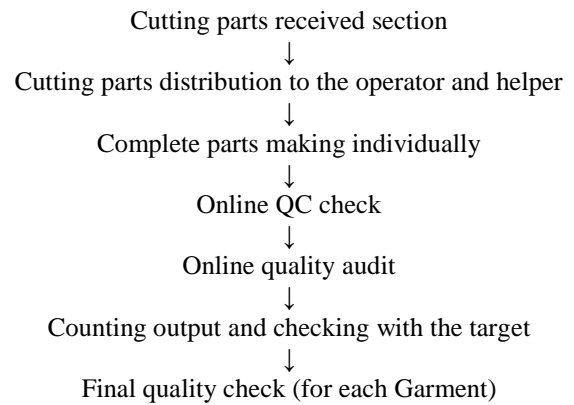
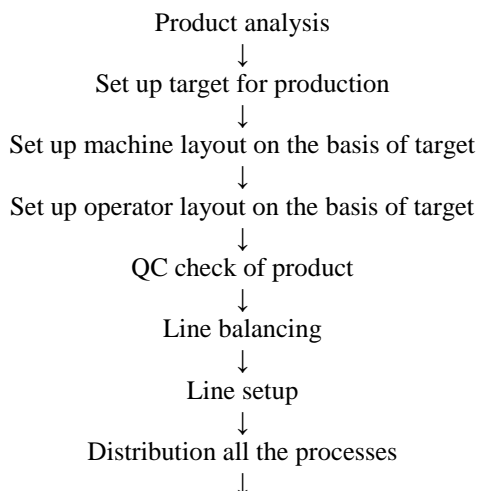

### 2.6 FINISHING

Ironing as well as packing of the garments are done.

#### 2.6.1 IRONING

Pressing or ironing is the most important finishing process in readymade garments sector which is done by subjecting a cloth to heat and pressure with or without steam to remove unwanted creases and to impart a flat appearance to the garments. Pressing or ironing also done to introduce creases in the apparel. In the garments manufacturing industries, pressing is termed as ironing.

#### 2.6.2 PACKING

Packing is the part of garment finishing. It is done by the requirement of buyer. Various types of packing accessories are available in store room such as polybag, packing board, tissue paper, hanger, scotch tape, gum tape, carton etc.

Make shipping mark according to P/O,

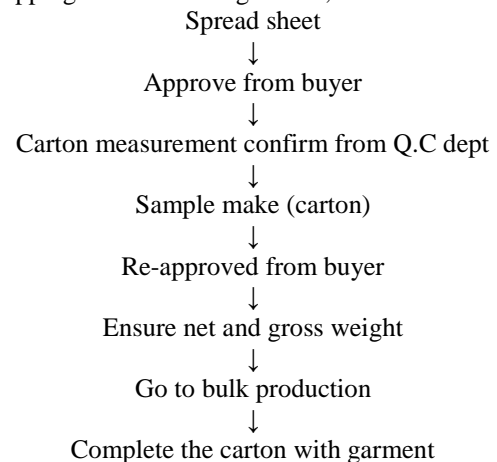

## III. SYSTEM ANALYSIS

### 3.1 PROPOSED SYSTEM

In industry monitoring system is done manually by individual supervisor in each section. Workers does not the finished target continuously. The hour wise finished count is entered in the notice board by manually by supervisor. So the workers are not interested to know their count by seeing notice board. So the proposed method is by displaying the hour count

in the led tv in each section will be easy to notice the count. And it will create interest among the workers.

The progress of work completion should be intimated to the workers to complete the assignment in time. Hourly targets are fixed to different teams to complete the work orders. In practical, some microphone based announcement systems are followed to intimate the progress to the workers and some companies follows the chalk and board procedures. Here we proposes a multi-node wireless broadcast system using radio frequency of range 2.4 GHz. In this system, an admin will enter the hourly target in a personnel computer. The proposed wireless system will works for the distance of 1200 meters in line of sight and 500-600 meters in off sight. The wireless device will act as a transceiver and in the receiver node, there will be a LCD/LED monitor to display the targets. For the purpose of compaction, maintenance free and for low power consumption, the LCD/LED is proposed here. Each and every nodes are assigned with different addresses, by the way the admin may easily sent the different data to different nodes.

IV. PROJECT DESCRIPTION

4.1 SYSTEM HARDWARE

4.1.1 ATMEGA 328

The Atmel AVR® core combines a rich instruction set with 32 general purpose working registers. All the 32 registers are directly connected to the Arithmetic Logic Unit (ALU), allowing two independent registers to be accessed in a single instruction executed in one clock cycle. The resulting architecture is more code efficient while achieving throughputs up to ten times faster than conventional CISC microcontrollers.

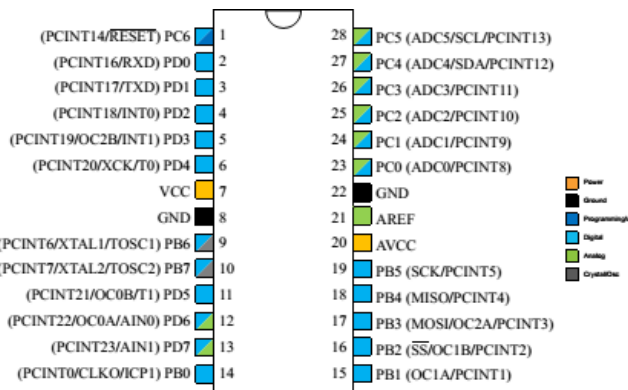

The ATmega328/P provides the following features: 32Kbytes of In-System Programmable Flash with Read-While-Write capabilities, 1Kbytes EEPROM, 2Kbytes SRAM, 23 general purpose I/O lines, 32 general purpose working registers, Real Time Counter (RTC), three flexible Timer/Counters with compare modes and PWM, 1 serial programmable USARTs, 1 byte-oriented 2-wire Serial Interface (I2C), a 6-channel 10-bit ADC (8 channels in TQFP and QFN/MLF packages), a programmable Watchdog Timer with internal Oscillator, an SPI serial port, and six software

selectable power saving modes. The Idle mode stops the CPU while allowing the SRAM, Timer/Counters, SPI port, and interrupt system to continue functioning. The Power-down mode saves the register contents but freezes the Oscillator, disabling all other chip functions until the next interrupt or hardware reset. In Power-save mode, the asynchronous timer continues to run, allowing the user to maintain a timer base while the rest of the device is sleeping. The ADC Noise Reduction mode stops the CPU and all I/O modules except asynchronous timer and ADC to minimize switching noise during ADC conversions. In Standby mode, the crystal/resonator oscillator is running while the rest of the device is sleeping. This allows very fast start-up combined with low power consumption. In Extended Standby mode, both the main oscillator and the asynchronous timer continue to run.

4.1.2 nRF TRANSCEIVER

nRF2401 is a single-chip radio transceiver for the world wide 2.4 - 2.5 GHz ISM band. The transceiver consists of a fully integrated frequency synthesizer, a power amplifier, a crystal oscillator and a modulator. Output power and frequency channels are easily programmable by use of the 3-wire serial interface. Current consumption is very low, only 10.5mA at an output power of -5dBm and 18mA in receive mode. Built-in Power Down modes makes power saving easily realizable.

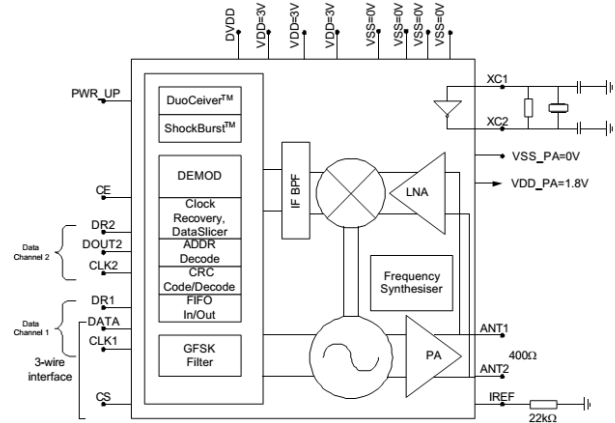
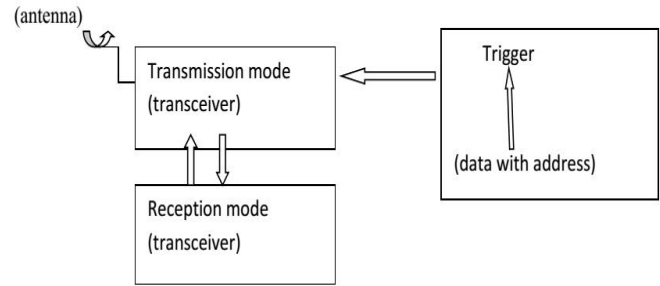
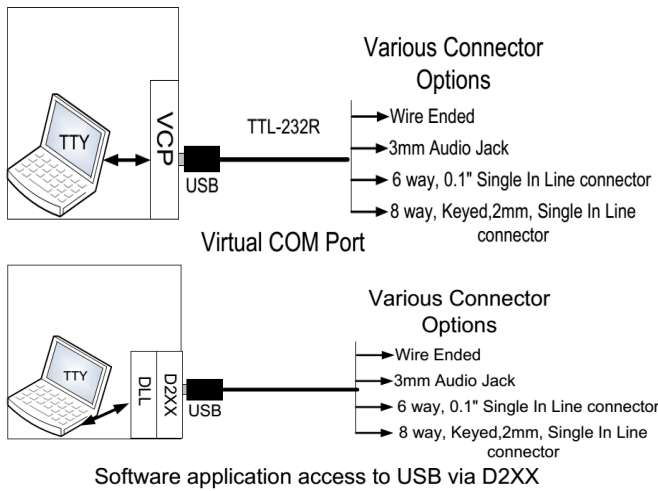

Figure 1 nRF2401 with external components.

4.1.3 USB TO TTL

The **TTL-232R** cables are a family of USB to TTL serial UART converter cables incorporating FTDI's FT232RQ USB to Serial UART interface IC device which handles all the USB signalling and protocols. The cables provide a fast, simple way to connect devices with a TTL level serial interface to USB. Each TTL-232R cable contains a small internal electronic circuit board, utilising the FT232R, which is encapsulated into the USB connector end of the cable. The other end of the cable comes with a selection of different connectors supporting various applications.



VI CIRCUIT DIAGRAM

V. BLOCK DIAGRAM

TRANSMITTER

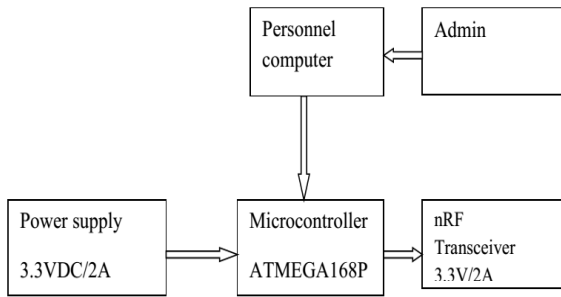

RECEIVER

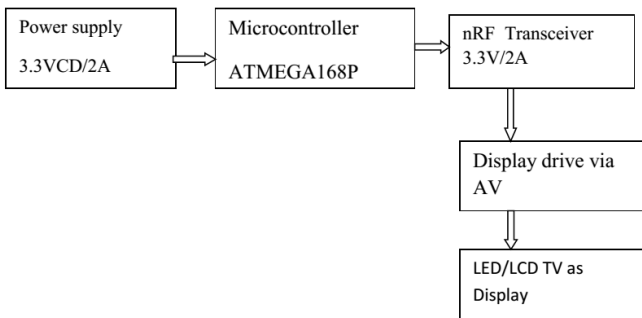

WORKING MODE

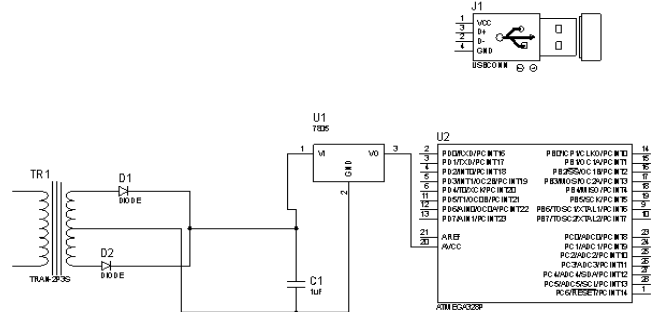

6.1 CIRCUIT OPERATION

The progress of work completion should be intimated to the workers to complete the assignment in time. Hourly targets are fixed to different teams to complete the work orders. In practical, some microphone based announcement systems are followed to intimate the progress to the workers and some companies follows the chalk and board procedures. Multi-node wireless broadcast system using radio frequency of range 2.4 GHz. In this system, an admin will enter the hourly target in a personnel computer. The proposed wireless system will works for the distance of 1200 meters in line of sight and 500-600 meters in off sight. The wireless device will act as a transceiver and in the receiver node, there will be a LCD/LED monitor to display the targets. For the purpose of compaction, maintenance free and for low power consumption, the LCD/LED is proposed here. Each and every nodes are assigned with different addresses, by the way the admin may easily sent the different data to different nodes.

VII ARDUINO

7.1.1 ARDUINO FEATURES

The Arduino Uno is a microcontroller board based on the ATmega328 (datasheet). It has 14 digital input/output pins (of which 6 can be used as PWM outputs), 6 analog inputs, a 16 MHz ceramic resonator, a USB connection, a power jack, an ICSP header, and a reset button. It contains everything needed to support the microcontroller; simply connect it to a computer with a USB cable or power it with a AC-to-DC adapter or battery to get started. The Uno differs from all preceding boards in that it does not

use the FTDI USB-to-serial driver chip.

### 7.1.2 Arduino IDE

The Arduino development environment contains a text editor for writing code, a message area, a text console, a toolbar with buttons for common functions, and a series of menus. It connects to the Arduino hardware to upload programs and communicate with them.



#### Arduino Board

- Get an Intel® Galileo, a USB cable, and a 12V Power Supply
- Connect the board

To upload Arduino sketches the Intel® Galileo board must be powered up and connected to your computer. Plug in the DC power supply into an outlet and into DC barrel jack on your Intel® Galileo board. You should see the green power LED light up near the USB port on the board. NOTE: If you are using the DC power supply included with the Intel® Galileo make sure you fit the appropriate plug. Plug the micro-USB cables to the micro USB connector on the board. Plug in other end of the USB cable to your computer. Wait a moment for the board to boot up. If you are plugging in your board for the first time and using Windows your computer will begin a driver install process. Allow this to complete before continuing on.

- Open the blink example

Open the LED blink example sketch: File > Examples > 1.Basics > Blink. You should see a window similar to the one below.

- Select your board

You'll need to select the Intel® Galileo in the Tools > Board menu.

- Select your serial port

Select the serial device of the board from the Tools | Serial Port menu. The easiest way to find what port the board is using is by disconnecting your board, restarting the IDE, and re-opening the menu; the entry that disappears should be the Intel® Galileo board. Reconnect the board, restart the IDE, and select that serial port.

- On Windows: The port is likely to be COM3 or higher in the Device Manager. COM1 and COM2 are usually reserved for hardware serial ports. Now the bottom right should match the COM port number of the "Intel Galileo Virtual Com Port (COM#)" from the Device Manager.
- On Linux: The port is likely to be /dev/ttyACM0.
- Upload and Run the Program

Click the Upload button in the upper left to load and run the sketch on your board. You should see a "Done Uploading" and a "Transfer complete" when it has uploaded.

### VIII. OUTPUT

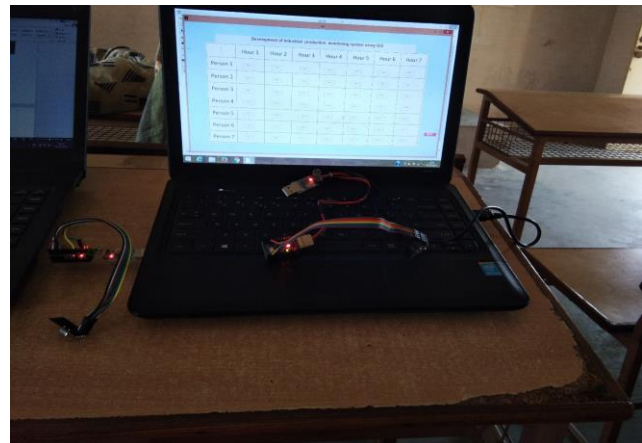

### IX. MERITS & DEMERITS

#### 9.1 MERITS

- Power is saved by using less components
- To reduce man power in the knitting industries.
- To create competition among workers to increase the outcome.
- To achieve the maximum target in shorten period.

#### IX. CONCLUSION

In textile industries, the problem is that there is less gain of product due to lack of interest of the workers because of the continuity of the same work. In order to achieve the maximum gain in a shortest period as well as creating interest among the workers, Design of multimode wireless broadcasting system using nRF is proposed. In textile industries, the progress of work completion should be intimated to the workers to complete the assignment in time. Hourly targets are fixed to different teams to complete the work orders. In practical, some microphone based announcement systems are followed to intimate the progress to the workers and some companies follows the chalk and board procedures. Here we proposes a multi-node wireless broadcast system using radio frequency of range 2.4 GHz. In this system, an admin will enter the hourly target in a personnel computer. The proposed wireless system will works for the distance of 1200 meters in line of sight and 500-600 meters in off sight. The wireless device will act as a transceiver and in the receiver node, there will be a LCD/LED monitor to display the targets. For the purpose of compaction, maintenance free and for low power consumption, the LCD/LED is proposed here. Each and every nodes are assigned with different addresses, by the way the admin may easily sent the different data to different nodes.

#### X. REFERENCES

A. An-An Lu, Student Member, IEEE, Xiqi Gao, Fellow, IEEE, Yahong Rosa Zheng, Fellow, IEEE, and Chengshan Xiao, Fellow, Linear precoder design for swipt in mimo broadcasting systems with discrete input signals: manifold

optimization approach IEEE VOL. 65, NO. 7, JULY 2017W.K.

B. Xianan Wang, Xiaoxiang Wang, and Yanyan Qi, IEEE, Low-Complexity Transceiver Design for MIMO Broadcast Systems, VOL. 18, NO. 9, SEPTEMBER 2014

C. Youngkil Suh, Student Member, IEEE, Jonghyun Baik, Student Member, IEEE, Nazanin Rahnavard, Member, IEEE, and Jun Heo, Member, IEEE Fountain Code Design for Broadcasting Systems With Intermediate-State Users, VOL. 63, NO. 9, SEPTEMBER 2015

D. Mohammad Esmaeilzadeh, Student Member, IEEE, Parastoo Sadeghi, Senior Member, IEEE, and Neda Aboutorab, Member, IEEE Random Linear Network Coding for Wireless Layered Video Broadcast: General Design Methods for Adaptive Feedback-Free Transmission, VOL. 65, NO. 2, FEBRUARY 2017

E. Jon Barrueco, Jon Montalban, Cristina Regueiro, Manuel Vélez, Juan Luis Ordiales, Heung-Mook Kim, Member, IEEE, Sung-Ik Park, Senior Member, IEEE, and Sunhyoung Kwon, Member, IEEE, Constellation Design for Bit-Interleaved Coded Modulation (BICM) Systems in Advanced Broadcast Standards, VOL. 63, NO. 4, DECEMBER 2017

F. Feng Wang, Member, IEEE, Jie Xu, Member, IEEE, Xin Wang, Senior Member, IEEE, and Shuguang Cui, Fellow, IEEE, Joint Offloading and Computing Optimization in Wireless Powered Mobile-Edge Computing Systems, DOI 10.1109/TWC.2017.2785305

G. Antonio Maria Cipriano, Cecile Gomez, Thales Communications and Security 160, Bd. de Valmy, Colombes, France Design and Evaluation of Cooperative Broadcast in a Wireless Mesh Network based on 3GPP LTE, 978-1-4673-0762-8/12/\$31.00 ©2012

H. Oscar Fresnedo, José P. González-Coma, Luis Castedo Department of Electronics and Systems University of A Coruna, SPAIN {ofresnedo, jose.gcoma, luis}@udc.es Design of Analog Joint Source-Channel Coding Systems for Broadcast Channels with MSE Balancing, 2015

Author <sup>1</sup>N.manikandaprabu received his B.E degree in Electronics and Communication Engineering from Nandha Engineering College, Erode, Tamilnadu, in 2011 and the M.E degree in Embedded Systems from Nandha Engineering College, Tamilnadu, in 2013. He is currently an Assistant Professor with Department of Electronics and Communication Engineering, Nandha Engineering College, Perundurai, Tamilnadu, India.

Author <sup>2</sup>K.Karthikeyan currently pursuing his B.E degree in Electronics and Communication Engineering from Nandha Engineering College, Perundurai, Tamilnadu, India

Author <sup>3</sup>B.Maheswari currently pursuing her B.E degree in Electronics and Communication Engineering from Nandha Engineering College, Perundurai, Tamilnadu, India

Author <sup>4</sup>S.Nandha Kumar currently pursuing his B.E degree in Electronics and Communication Engineering from Nandha Engineering College, Perundurai, Tamilnadu, India

Author <sup>5</sup>C.Poovizhi currently pursuing her B.E degree in Electronics and Communication Engineering from Nandha Engineering College, Perundurai, Tamilnadu, India