



---

## International Journal of Intellectual Advancements and Research in Engineering Computations

---

### 90 Degree rotate steering mechanism in electrical cars

Mr. K. Pradeepkumar<sup>1</sup>, B. Kavin<sup>2</sup>, S. Manoj<sup>2</sup>, R. Nanthakumar<sup>2</sup>, S. Prabanjan<sup>2</sup>

<sup>1</sup>Associate Professor, <sup>2</sup>UG Students

Department of Mechanical Engineering, Nandha Engineering College, Erode - 52

---

#### ABSTRACT

The four wheel steering controlled vehicle is a new innovative concept which is mainly used for four wheeler vehicles. In most active four-wheel steering systems, the rear wheels are steered by a controller and actuators. This allows the vehicle to turn in a significantly smaller radius, sometimes critical for large trucks or tractors and vehicles with trailers. So we are introducing small model of four wheeler steering control through this project. It consists of the following parts rack and pinion gear arrangement, bevel gear arrangement, axle, and Vehicle model. It is nothing but the steering control with four wheel drive in 30 degree and also 90 degree angle. It is a new innovative concept which is mainly used for four wheeler vehicles. This allows the vehicle to turn in a significantly smaller radius, sometimes critical for large trucks or tractors and vehicles with trailers. We implement two steering modes in a single vehicle and the modes can be changed as needed. The first mode wheel drive in 300 and second mode vehicle wheel drive in 900.

**Keyword:** Wheels, Bevel Gear, Rack and Pinion

---

#### INTRODUCTION

Steering is the term applied to the collection of components, linkages, etc. which will allow for a vessel (ship, boat) or vehicle (car) to follow the desired course. An exception is the case of rail transport by which rail tracks combined together with railroad switches provide the steering function. The most conventional steering arrangement is to turn the front wheels using a hand-operated steering wheel which is positioned

in front of the driver, via the steering column, which may contain universal joints to allow it to deviate somewhat from a straight line. Other arrangements are sometimes found on different types of vehicles, for example, a tiller or rear-wheel steering. Tracked vehicles such as tanks usually employ differential steering that is, the tracks are made to move at different speeds or even in opposite directions to bring about a change of course [1].

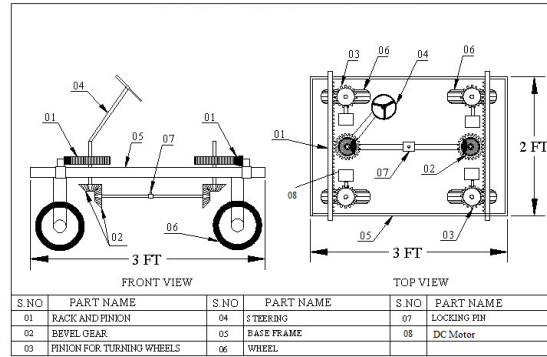

**Fig. 1 Steering Mechanism**

## PROBLEM IDENTIFICATION

There are so much of problems in parking area while parking vehicles. It has more space requires during turn a vehicle. It has more difficulties to parking a vehicle in market places and hospitals during using of the normal steering. But we are using and implementing new innovative concept to the steering system in parking places only. When using this steering mechanism we can reduce this type of problems and easily turn vehicles during a drive condition [2-4].

## COMPONENTS REQUIRED

- Rack and pinion

- Bevel gear
- Dc motor
- Car model

## DESCRIPTION OF EQUIPMENTS

### Rack and Pinion

A rack and pinion is a pair of gears which convert rotational motion into linear motion. The circular pinion engages teeth on a flat bar the rack. Rotational motion applied to the pinion will cause the rack to move to the side, up to the limit of its travel. The pinion is in mesh with a rack. The circular motion of the pinion is transferred into the linear rack movement [5].



**Fig. 2 Rack and Pinion**

### Bevel Gear

Bevel gears are gears where the axes of the two shafts intersect and the tooth-bearing faces of the gears themselves are conically shaped. Bevel gears

are most often mounted on shafts that are 90 degrees apart, but can be designed to work at other angles as well. The pitch surface of bevel gears is a cone.



**Fig. 3 Bevel Gear**

## STEERING SYSTEM

The steering system is to achieve angular motion of the front wheels to negotiate a turn. This is done through linkage and steering gear which convert the rotary motion of the steering wheel into angular motion of the front road wheels.

### Secondary functions of the steering system are

1. To provide directional stability of the vehicle when going straight ahead.
2. To provide perfect steering condition, perfect rolling motion of the road wheels at all time.
3. To facilitate straight ahead recovery after completing a turn. To minimize tire wear.

Till recently all vehicles were steered by turning the front wheels in the desired direction, with the rear wheels following. However, lately all-wheel-steering has been designed and employed in some selected vehicles.

## DC MOTOR PRINCIPLE

A machine that converts direct current power into mechanical power is known as D.C Motor. Its generation is based on the principle that when a current carrying conductor is placed in a magnetic field, the conductor experiences a mechanical force.

### Motor Principle

An electric motor is a machine which converts a electrical energy to mechanical energy.

All D.C machines have three principal components

- i. Field system
- ii. Armature core

- iii. Armature winding

## CALCULATION

DC Motor Specifications

Voltage : 12volts

Speed : 30 R.P.M

DC motor : 18watts

Gear Calculations

Number of teeth (T) = 16

Outer diameter (OD) = 2.54mm

Pitch circle diameter

$$\text{PCD} = (T * \text{OD}) / (T + 2) \\ = 2.257\text{mm}$$

Module (M)

$$M = (D / T) \\ = 0.158\text{mm}$$

Circular pitch (P)

$$P = \pi m \\ = 0.496\text{mm}$$

Clearance = 1.5 M = 0.237mm

Dedendum = 1.57 M = 0.248mm

Tooth thickness = D sin(90/T) \\ = 0.248mm

Chordal depth = (D/2) [1 - cos(90/T)] + 2.67 \\ = 0.164mm

## WORKING PRINCIPLE

In active four wheel steering system. All four wheels turn at the same time when the driver steers. This allows the vehicle to turn in significantly smaller radius in 30 degree and 90 degree. And then 30 degree movement

In our project, consisting of steering rack and pinion, gears, bevel gear and lock pin. The rack and pinion is coupled with front wheels

and turns by the steering. Bevel gear arrangement is coupled under spur gear arrangement and coupled with rear wheel gear arrangement. The lock pin is placed centre of bevel gear shaft and used to engage and disengage rear wheel shaft.

Four wheel steering found its most widespread use in monster trucks in critical road, parking area and in desert roads. So we are introducing small model of four wheeler steering control through this project.

## CONCLUSION

The project carried out by us made an impressing task in the field of automobile industries. It is very usefully for driver while driving the vehicle. This project has also reduced the cost involved in the concern. Project has been designed to perform the entire requirement task which has also been provided.

## REFERENCES

- [1]. Arunkumar s , chandankumarsahu, yubaraj g , jahangeer a -360 degree wheel rotation vehicle- 2(5), 2017, 75-8
- [2]. Dilip s choudhari-four wheel steering system for future- 3(4), 2014
- [3]. Lohith.s, Dr. S. R. Shankapal, m. H. Monish gowda -development of four wheel steering system for a car- 12(1), 2013.
- [4]. Mandar Harer<sup>1</sup>, Vaibhav Desai<sup>2</sup>, Ajay Gawali<sup>3</sup>, kirtimanachavan<sup>4</sup>, Vishal Aradhya<sup>5</sup>-Design and Development of 90 Degree Steering System-(ICIIIME 2017) Volume: 5 Issue: 6
- [5]. Sathish kumark , mohammed shabirullah -design and fabrication of “360 degree car parking”- 116(16) 2017, 171-1.