



International Journal of Intellectual Advancements and Research in Engineering Computations

Iot based unified power management system with economic features

K.Sathyasree¹, S.Ajithkumar², D.Karthik², A.Murugasamy², R.Sudhakar²

¹*Asst. Prof., Department of EEE, Nandha Engineering College, Erode, India*

²*UG scholar, Department of EEE, Nandha Engineering College, Erode, India*

Email : arkss4@gmail.com

ABSTRACT - With the development of the social economy, more and more appliances have been presented in a house. It comes out a problem that how to manage and control these increasing various appliances efficiently and conveniently so as to achieve more comfortable, security and healthy space at home. In this paper, a smart control system based IOT (internet of things) has been proposed to solve the above problems. It will automatically manage and control all the appliance in the house.

Keywords: IOT, PIC microcontroller

I.INTRODUCTION

Green building refers to a building that is environmentally responsible and resource-efficient throughout a building's life-cycle: from siting to design, construction, operation, maintenance, renovation, and demolition .To some extent, an intelligent building can be regarded as a green house since it pursues the same objectives with the ones of a green building. A green building constructed is to meet the requirements of economy, utility, durability, and comfort .

Therefore, that not only requires close cooperation of the design team, the architects, the engineers, and the client at all project stages, but also ask for the efficient operation, control and management of all appliances and building facilities with a building automation system. While, people are pursuing ever-growing high quality of their lives today. This leads to more and more facilities and home appliances

poured into their buildings. How to control and manage these versatile facilities and appliances in a house? To work out a solution is not easy in that there exists two obvious main reasons. First, there really are big differences among these facilities or appliances from the angle of control. Here the control plant with home appliances is a complex system. Hence, a simple conventional control system may do not work. Second, a man in a green building would expect to occupy a comfort, healthy, security, economy and convenient space. Therefore, for a control system of a green building, it can firstly seamlessly integrates all appliances as an big system with greater efficiency; Then it can provide a management and optimization strategy for an on-going system which will generate a series of optimal strategies for each appliance system to meet occupancies' requirements.

In existing system applied for Green building refers to a building that is environmentally responsible and resource efficient throughout a building's life-cycle: from siting to design, construction, operation, maintenance, renovation, and demolition. Therefore, that not only requires close cooperation of the design team, the architects, the engineers, and the client at all project stages, but also ask for the efficient operation, control and management of all appliances and building facilities with a building automation system. The normally used system consists of remote or other source to control but they have limited space. This paper overcomes the above problem.

II.KNOWLEDGE OF INTERNET OF THINGS

The Internet of things (stylized Internet of Things or IoT) is the inter-networking of physical devices, vehicles (also referred to as "connected devices" and "smart devices"), buildings, and other items—embedded with electronics, software, sensors, actuators, and network connectivity that enable these objects to collect and exchange data. In 2013 the Global Standards Initiative on Internet of Things (IoT-GSI) defined the IoT as "the infrastructure of the information society." The IoT allows objects to be sensed or controlled remotely across existing network infrastructure, creating opportunities for more direct integration of the physical world into computer-based systems, and resulting in improved efficiency, accuracy and economic benefit in addition to reduced human intervention.

When IoT is augmented with sensors and actuators, the technology becomes an instance of the more general class of cyber-physical systems, which also encompasses technologies such as smart grids, smart homes, intelligent transportation and smart cities. Each thing is uniquely identifiable through its embedded computing system but is able to interoperate within the existing Internet infrastructure. Experts estimate that the IoT will consist of almost 50 billion objects by 2020.

Typically, IoT is expected to offer advanced connectivity of devices, systems, and services that goes beyond machine-to-machine (M2M) communications and covers a variety of protocols, domains, and applications. The interconnection of these embedded devices (including smart objects), is expected to usher in automation in nearly all fields, while also enabling advanced applications like a smart grid, and expanding to areas such as smart cities.

"Things," in the IoT sense, can refer to a wide variety of devices such as heart monitoring implants, biochip transponders on farm animals, electric clams in coastal waters, automobiles with built-in sensors, DNA analysis devices for environmental/food/pathogen monitoring or field operation devices that assist firefighters in search and rescue operations. Legal scholars suggest to look at

"Things" as an "inextricable mixture of hardware, software, data and service".

These devices collect useful data with the help of various existing technologies and then autonomously flow the data between other devices. Current market examples include home automation (also known as smart home devices) such as the control and automation of lighting, heating (like smart thermostat), ventilation, air conditioning (HVAC) systems, and appliances such as washer/dryers, robotic vacuums, air purifiers, ovens or refrigerators/freezers that use Wi-Fi for remote monitoring.

As well as the expansion of Internet-connected automation into a plethora of new application areas, IoT is also expected to generate large amounts of data from diverse locations, with the consequent necessity for quick aggregation of the data, and an increase in the need to index, store, and process such data more effectively. IoT is one of the platforms of today's Smart City, and Smart Energy Management Systems.

III.PROPOSED METHOD

This paper will give the solution for above mentioned problems. Here by using IOT we can control our home appliance at any where.

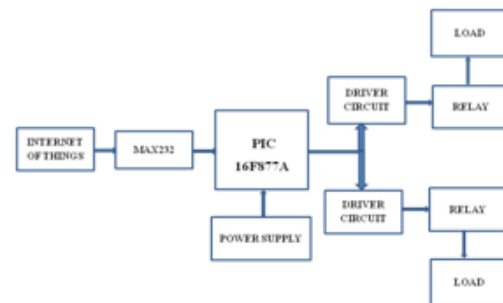

Block diagram of proposed system

"Things," in the IoT sense, can refer to a wide variety of devices such as heart monitoring implants, biochip transponders on farm animals, electric clams in coastal waters, automobiles with built-in sensors, DNA analysis devices for environmental/food/pathogen monitoring or field operation devices that assist firefighters in search and rescue operations. Max circuit used for conversion purpose. Various microcontrollers offer different kinds of memories. Easy programming and Erasing are other features of PIC 16F877.

A power supply is an electronic device that supplies electric energy to an electrical load. The primary function of a power supply is to convert one form of electrical energy to another and, as a result, power supplies are sometimes referred to as electric power converters. Some power supplies are discrete, stand-alone devices, whereas others are built into larger devices along with their loads. Various types of power supplies' are DC power supply and AC power supply. Transistor, diode are combined to perform the driver circuit operations. Various types of load are combined to the driver circuit through relay. Relay performs the on and off operations. In this project we should connect the three loads. It will be extend up to eight loads.

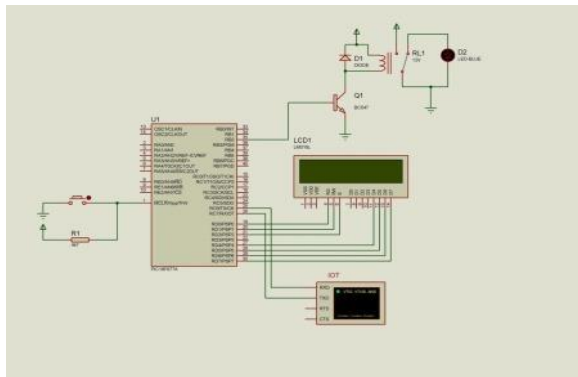

Circuit Diagram of Proposed system

The proposed system tries to provide User centered experience for home appliances controlling. The concept is that users should not be concerned about the appliances, but their activities themselves. With this system, users do not need to look for the specific function of appliance on the remote control. This system control the home appliances via Internet of things (IOT) with some embedded systems.

IOT is used for transmitting and receiving the data from internet and transmit the commands to controller and controller do its instruction on appliances like power ON / OFF operations. Microcontroller receive the information from IOT via internet and if its complete its works with the help of some components like relay and show its works on LCD display. LCD display show what kind of working proceed at home. From this project we can maintain home appliance at anywhere and anytime with help of internet.

IV.RESULT AND DISCUSSION

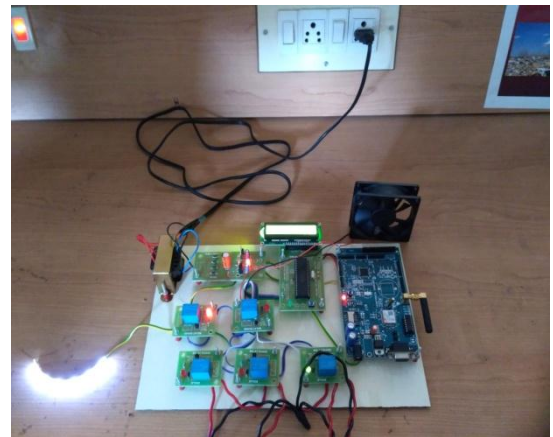

- In this project we had used five loads.like two dc loads(led,coolant fan) three ac loads(resistive load)
- By using iot to control various types of loads.

ADVANTAGES

- It is very efficient over existing system.
- Usage of cost is low.
- Data's can be transmit from internet to our home appliance via IOT.
- We can operate home appliance easily from internet.

DISADVANTAGES

- Interference of network causes operation is delayed

V.CONCLUSION

Through an internet network, home access is possibly done anywhere with a responsive web interface that

can be accessed using a wide variety of sizes and screen resolutions supporting modern web technologies. These features will provide a sense of security to home owners. This work built a home automation system that provides services in the monitoring and management of things in the house.

VI.FUTURE SCOPE

The future extension of this project can be done in controlling the electronic appliances with high signal rate. Smart agriculture, smart transportation, Healthcare, Manufacturing, Predictive Analysis, Automobiles can be done by using IOT.

VII.REFERENCE

[1].K. S. Choi, Y. K. Ahn, Y. C. Park, W. C. Park, H. M. Seo, K. M. Jung, K. H. Seo, "Architectural design of home energy saving system based on realtime energy-awareness", *Ubiquitous Information Technologies Applications 2009. ICUT '09*, pp. 1-5, December 2009.

[2].A.-H. Mohsenian-Rad, V. Wong, J. Jatskevich, R. Schober, "Optimal and autonomous incentive-based energy consumption scheduling algorithm for smart grid", *Innovative Smart Grid Technologies 2010 (ISGT 2010)*, January 2010.

[3].BP, "Energy outlook 2030," http://www.bp.com/liveassets/bp_internet/global_bp/STAGING/global_assets/downloads/O/2012_2030_energy_outlook_booklet.

[4].Lawrence Berkeley National Laboratory, "Global energy," <http://newscenter.lbl.gov/wp-content/uploads/majumdar-globalenergy>.

[5].Agency for Natural Resources and Energy, "Energy conservation policies of japan," <http://www.enecho.meti.go.jp/policy/saveenergy/save01/genjo> English.