



High gain DC-DC converter with dual coupled inductor using microcontroller

Mrs. Pratheeba.C^{#1},

Dhivya.P^{#2}, Jeevitha.A^{#3}, Loganayaki.A^{#4}, Maragathasree.P^{#5}

¹Assitant professor, ²⁻⁵UG Scholars, Electrical and Electronics Dept., Nandha Engineering College (Autonomous), Erode-52, Tamil Nadu, India.

Email : pratheebachenniappan@gmail.com

Abstract

High voltage gain dc–dc converters are required in many industrial applications such as photovoltaic and fuel cell energy systems, high-intensity discharge lamp (HID), dc back-up energy systems, and electric vehicles. This paper presents a novel input-parallel output-series boost converter with dual coupled inductors and a voltage multiplier module. On the one hand, the primary windings of two coupled inductors are connected in parallel to share the input current and reduce the current ripple at the input. On the other hand, the proposed converter inherits the merits of Dual coupled series-connected output capacitors for high voltage gain, low output voltage ripple, and low switch voltage stress. Moreover, the secondary sides of two coupled inductors are connected in series to a regenerative capacitor by a diode for extending the voltage gain and balancing the primary-parallel currents. In addition we

implemented Fuzzy control to stabilize the output voltage for any fluctuating input voltage. And SPWM technique to reduce power loss

1. Introduction

Nowadays high voltage gain DC-DC converters are required in many industrial applications. Photovoltaic energy conversion systems and fuel-cell systems usually need high step up and large input current dc-dc converters to boost low voltage (18-56 V) to high voltage (200-400 V) for the grid-connected inverters. High-intensity discharge lamp ballasts for automobile headlamps call for high voltage gain DC-DC converters to raise a battery voltage of 12 V up to 100 V at steady operation. Also, the low battery voltage of 48 V needs to be converted to 380 V in the front-end stage in some uninterruptible power supplies and telecommunication systems by high step-up converters. Theoretically, a basic boost converter can provide infinite voltage gain

with extremely high duty ratio. In practice, the voltage gain is limited by the parasitic elements of the power devices, inductor and capacitor. Moreover, the extremely high duty cycle operation may induce serious reverse-recovery problem of the rectifier diode and large current ripples, which increase the conduction losses. On the other

hand, the input current is usually large in high output voltage and high power conversion, but low-voltage-rated power devices with small on resistances may not be selected since the voltage stress of the main switch and diode is, respectively, equivalent to the output voltage in the conventional boost converter. Many other converter topologies have developed for high step up gain. Here a high gain input-parallel output-series DC-DC converter with

dual coupled inductors are designed. This configuration inherits the merits of high voltage gain, low output voltage ripple, and low voltage stress across the power switches. Moreover, the converter is able to turn ON the active switches at zero current and alleviate the reverse recovery problem of diodes by reasonable leakage inductances of the coupled inductors

2. Existing system

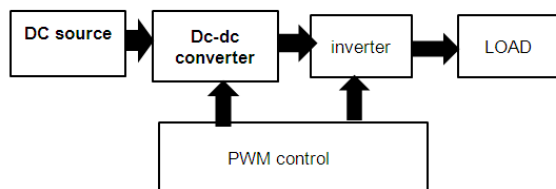

The existing system is open loop system so there is no voltage stability in output. In open

loop if input had fluctuation output voltage varies. So ripples will be high. In existing system dc source is given to the dc to dc converter. The dc signal is given to the inverter. PWM signal is produced by the PWM control and given to the both dc to dc converter and inverter. The inverted signal is given to the load.

3. Proposed system

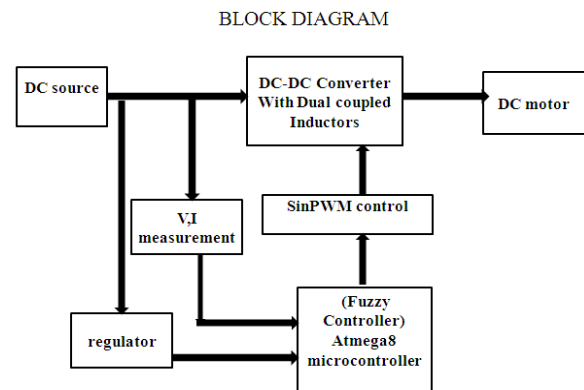

We implement closed loop fuzzy algorithm with Dual coupled converter so output voltage is very stable and ripple reduction. If input voltage had fluctuation also output voltage will be constant. Fuzzy is a new method in optimization technique so response time is very lower than other techniques. Implement speed control in induction motor. To design a low cost wind generation for areas without grid access or for backup power. Affordable, High efficiency, Battery charger stage for night time use, Maximum power point tracking for best use of photovoltaic panel. In proposed system the dc source is given to the dc to dc converter with dual coupled inductor. The feedback signal is given to the VI measurement for increasing the voltage

level when decreasing the supply voltage. The regulated 5V is given to the microcontroller. It has three ports namely A/D converter port, serial communication port, and SPWM signal generator. The SPWM signal is generated by SPWM control and given to the converter. The dual coupled inductor will increase the voltage level. This voltage gain is given to the load.

4. Hardware requirements

4.1. Power Supply:

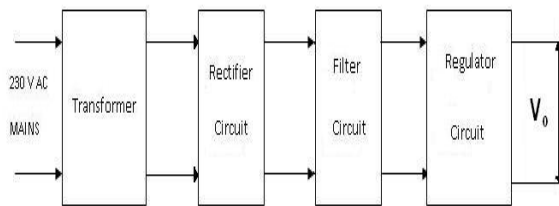

Power Supply is an important part of a circuit. It provides required supply to different blocks of the circuit from input 230V AC. The main blocks include transformer, rectifier circuit, filter circuit, and regulator circuit. For our project we require + 5 Volt and +12 Volts supply. +5 Volts is given to Micro-controller board.

4.2. Microcontroller- Atmega8:

The ATmega8 provides the following features: 8 Kbytes of In-System Programmable Flash with Read-While-Write capabilities, 512 bytes of EEPROM, 1 Kbyte of SRAM, 23 general purpose I/O lines, 32 general purpose working registers, three flexible Timer/Counters with compare modes, internal and external interrupts, a serial

programmable USART, a byte oriented Two wire Serial Interface, a 6-channel ADC (eight channels in TQFP and QFN/MLF packages) with 10-bit accuracy, a programmable Watchdog Timer with Internal Oscillator, an SPI serial port, and five software selectable power saving modes. The Idle mode stops the CPU while allowing the SRAM, Timer/Counters, SPI port, and interrupt

system to continue functioning. The Power down mode saves the register contents but freezes the Oscillator, disabling all other chip functions until the next Interrupt or Hardware Reset. In Power-save mode, the asynchronous timer continues to run, allowing the user to maintain a timer base while the rest of the device is sleeping. The ADC Noise Reduction mode stops the CPU and all I/O modules except asynchronous timer and ADC, to minimize switching noise during ADC conversions. In Standby mode, the crystal/resonator Oscillator is running while the rest of the device is sleeping. This allows very fast start-up combined with low-power consumption. The ATmega8 is supported with a full suite of program and system development tools, including C compilers, macro assemblers, program simulators, and evaluation kits.

4.3. DC motor

A DC motor is any of a class of rotary electrical machines that converts direct current electrical power into mechanical power. The most common types rely on the forces produced by magnetic fields. Nearly all types of DC motors have some internal mechanism, either electromechanical or electronic, to periodically change the

direction of current flow in part of the motor.

DC motors were the first type widely used, since they could be powered from existing direct-current lighting power distribution systems. A DC motor's speed can be controlled over a wide range, using either a variable supply voltage or by changing the

strength of current in its field windings. Small DC motors are used in tools, toys, and appliances. The universal motor can operate on direct current but is a lightweight motor used for portable power tools and appliances. Larger DC motors are used in propulsion of electric vehicles, elevator and hoists, or in drives for steel rolling mills. The advent of power electronics has made replacement of DC motors with AC motors possible in many applications.

4.4. Dc Dc Converter

A boost converter (step-up converter) is a power converter with an output DC voltage greater than its input DC voltage. It is a class of switching-mode power supply (SMPS) containing at least two semiconductor switches (a diode and a transistor) and at least one energy storage element. Filters made of capacitors (sometimes in combination with inductors) are normally added to the output of the converter to reduce output voltage ripple.

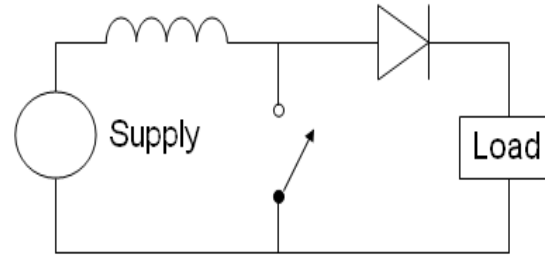

The basic schematic of a boost converter. The switch is typically a MOSFET, IGBT, or BJT. Power can also come from DC sources such as batteries, solar panels, rectifiers and DC generators. A process that

changes one DC voltage to a different DC voltage is called DC to DC conversion. A boost converter is a DC to DC converter with an output voltage greater than the source voltage. A boost converter is sometimes called a step-up converter since it “steps up” the source voltage. Since power ($P = VI$) must be conserved, the output current is lower than the source current.

5. Software Techniques

5.1. Code Vision AVR

The AVR is a modified Harvard architecture 8-bit RISC single chip microcontroller which was developed by Atmel in 1996. The AVR was one of the first microcontroller families to use on-chip flash memory for program storage, as opposed to one-time programmable ROM, EPROM, or EEPROM used by other microcontrollers at the time.

5.2. Program memory

Program instructions are stored in volatile flash. Although the MCUs are 8-bit, each

instruction takes one or two 16-bit words. The size of the program memory is usually indicated in the naming of the device itself (e.g., the ATmega64x line has 64 kB of flash while the ATmega32x line has 32 kB). There is no provision for off-chip program memory; all code executed by the AVR core must reside in the on-chip flash. However, this limitation does not apply to the AT94 FPSLIC AVR/FPGA chips.

5.3. Embedded C

Embedded C is used for microcontroller programming. There is a large and growing international demand for programmers with 'embedded' skills, and many desktop developers are starting to move into this important area. Because most embedded projects have severe cost constraints.

5.4. Programming interfaces

There are many means to load program code into an AVR chip. The methods to program AVR chips vary from AVR family to family.

5.5. ISP

The In-system programming (ISP) programming method is functionally performed through SPI, plus some twiddling of the Reset line. As long as the SPI pins of the AVR aren't connected to anything disruptive, the AVR chip can stay soldered on a PCB while reprogramming. All that's needed is a 6-pin connector and programming adapter. This is the most common way to develop with an AVR.

The Atmel AVR ISP mkII device connects to a computer's USB port and performs in-system programming using Atmel's software.

5.6. Program execution

Atmel's AVR's have a two stage, single level pipeline design. This means the next machine instruction is fetched as the current one is executing. Most instructions take just one or two clock cycles, making AVR's relatively fast among the eight-bit microcontrollers.

The AVR family of processors was designed with the efficient execution of compiled C code in mind and has several built-in pointers for the task.

6. Results and Discussion

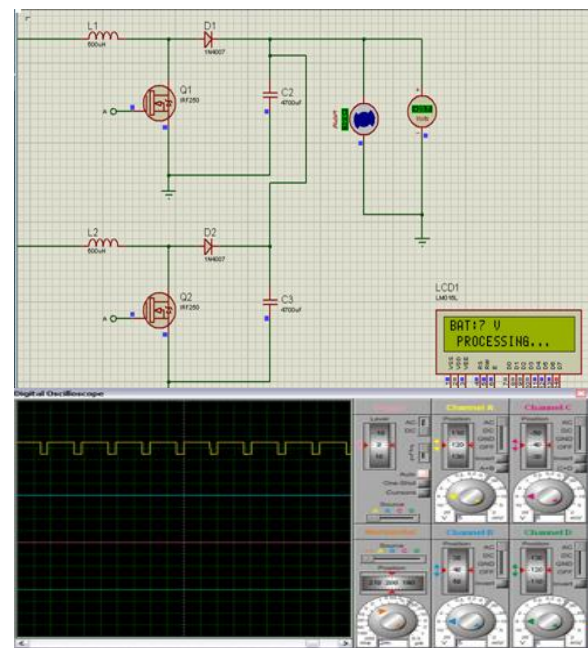

In this system, if the source voltage is decreased the output voltage is boost. For example, the given source voltage is 12V, when it is decreased to 7V the output voltage is boosted to 23.7V.

Conclusion

For low input-voltage and high step up power conversion, this paper has

successfully developed a high-voltage gain dc-dc converter by input-parallel output-series and inductor techniques. We used fuzzy control to stabilize the output voltage for any fluctuating input voltage and SPWM technique to reduce power loss. Dual coupled inductor is used to increase the voltage gain as well as current gain.

Reference

1. L. Henrique, S. C. Barreto, P. P. Praca, D. S.Oliveira Jr., and R. N. A. L. Silva, "High-voltage gain boost converter based on three-state commutation cell for battery charging using PV panels in a single conversion stage," *IEEE Trans. Power Electron.*, vol. 29, no. 1, pp. 150–158, Jan. 2014.
2. Y. P. Hsieh, J. F. Chen, T. J. Liang, and L. S. Yang, "Novel high step-up DC-DC converter for distributed generation system," *IEEE Trans. Ind. Electron.*, vol. 60, no. 4, pp. 1473–1482, Apr. 2013.
3. S. Chen, T. Liang, L. Yang, and J. Chen, "A cascaded high step-up dc-dc converter with single switch for micro source applications," *IEEE Trans. Power Electron.*, vol. 26, no. 4, pp. 1146–1153, Apr. 2011.