



Improving the Performance of a Refrigeration System by Utilizing Waste Heat from Condenser

M. BalaKumaran¹, T.Sivasubramaniyan², T.Santhosh², C.Sudharsan², V.Sudharsan².

Assistant Professor¹, UG Students²

Department of Mechanical Engineering, Nandha Engineering College, Erode- 52, Tamilnadu, India.

balamadhes@gmail.com,dhrasanraja69@gmail.com

Abstract- To review the energy saving associated with the improved utilization of waste heat from domestic refrigerator. Domestic refrigerator may be an operating continuously to maintain the proper food storage condition. The continuous operation of the equipment account more in electrical energy consumption. So it is that a significant and concrete effort should be made for the conserving energy through waste heat recovery. A significant amount of the waste heat was rejected by the condensers of the refrigerator. So an attempt has been made to utilize the waste heat from an condenser of the refrigerator. Practical use of waste heat from the domestic refrigerators are the typically to space heating and water heating in the minimum constructional maintenance and running cost. A cabin was installed in a domestic refrigerator with the condenser coils of refrigerator serving as heating coils inside the cabin. Known quantity of the water was heated by the condenser in coils due to convection currents thereby increasing the overall Cop of the refrigerator. Besides, the refrigerator may be used as a conventional refrigerator by keeping the cabin of the door open in case of the absence of heat sink.

Index words- Domestic refrigerator, air cooled condenser, heat recovery unit, experimental analysis.

1. INTRODUCTION

Refrigerators has become an essential commodity rather than luxury item. Household refrigerators is a common household appliances that consist of a thermally Insulated compartment and which when work, transfer heat from inside of the compartments to its external environment so that inside of the thermally insulated compartments is cooled to a temperature below the ambient temperature of the room. Heat rejection may occur directly to the air in the case of a conventional household refrigerator having air-cooled condenser or to water in the case of a water-cooled condensers. Tetrafluoroethane (HFC134a) refrigerant was now widely used in most of domestic refrigerator. Waste heat which is rejected

from the process at temperature enough high above the ambient temperature permit the recovery of energy for some useful purpose in economic manner the Heat can be recovered by using the water-cooled condenser and the system can work as a waste heat recovery units. The heat recovery from the condenser can be used for bathing, cleaning, laundry, dish washing etc. Low temperature waste heat may be useful in a supplementary way for preheating purposes Keeping this in mind, a technique, condensing heat of the refrigeration systems is proposed in this paper. The proposed system employs the combined air and water cooling (DE superheating) technique For condensing heat of refrigerators. This is the new system provides not only the refrigeration effect, but also hot water.

2. THEORY

A typical vapor compression system consist of the four major components i.e. compressor, condenser, expansion device and an evaporator are the depicted schematically in the Figure 1. Figure 2 is a thermodynamic diagram of the process where the number of points correspond to the numbered points in the Figure 1. The operation cycle consist of the compressing of low pressure vapor refrigerant to a high temperature vapor (process 1-2); condensing of high pressure vapor to the high pressure liquid (process 2-3); expanding high pressure liquid to the low pressured super cooled liquid (process 3-4); and the operating low pressure liquid to low pressure vapor (processes 4-1). The heat absorbed from the evaporator in process 4-1 is rejected to the outside ambient during the condensation process 2-3 and is generally a waste heat. Condensation process can be divided in three stages. Desuperheating 2-2a, condensation and the sub cooling. The saturation temperature by design is anywhere from ten to thirty degree above the heat sink fluid temperature, this ensure heat sink fluid can extract heat from the refrigerant. The superheat can be as much as 100 F or more above

saturation temperature. This so-called superheat is a part of waste heat that can be recovered from useful purposes through the use of a heat recovery unit. A heat recovery unit is special purpose of heat exchanger specifically designed to

- Remove the heat represented by process 2-3 in figure 2. Improved the overall system efficiency by using the water cooled condenser.
- Use of thermo syphon system to circulate the water to minimize pumping cost.
- Protection against the contamination of portable water via double wall

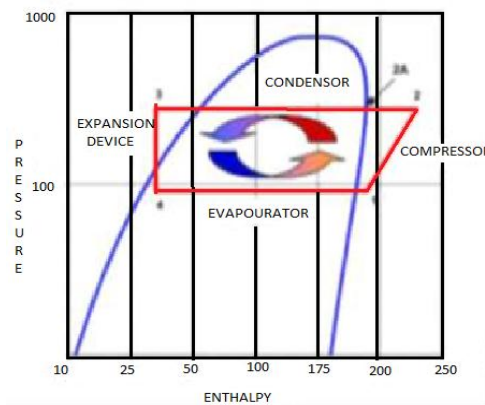

construction.

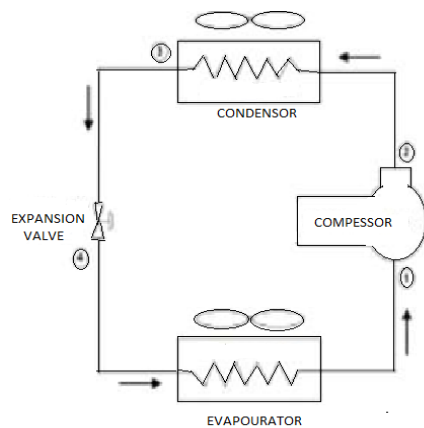

Fig. 1 P-H diagram

3. LITERATURE SURVEY

Romdhanebenslama developed the system that can recover heat from the condenser of the refrigerators. In this work air-cooled conventional condensers is replaced by another heat exchanger to heat water. The results show that water at a temperature of 60°C was produced by the systems. This paper also analyzed economic importance of waste heat recovery systems from the energy saving the point of view.

Shengshan Bi et al experimentally investigated the performance of a domestic refrigerator using TiO₂R600a nano refrigerants. The test results

shows that refrigerator performance was better than pure R600a system, with 9.62% less energy used with 0.52 g/L TiO₂R600 nanorefrigerants .

S.S.Hu, B.J.Huang et al conducted an experimental investigations on a split the air conditioner having water cooled condensers. They developed a simple water-cooled air conditioner utilizing a cooling tower with cellulose pad filling material to cool the water for condensing operations.

The experimental investigations verified that watercooled condensers and cooling tower result in the decreasing power consumption of the compressor designed and developed a thermo syphon heat recovery systems which can recover heat from a window air conditioners. They design two types of heat exchanger, concentric type heat exchangers & coiled heat exchangers and then it is retrofitted in to the air conditioning systems. They analyzed the performance of the systems with these two types of heat exchanger. The circulation of water through the heat exchangers is done with the thermo syphon effects which completely eliminate the need of pump. For having that, the heat exchanger are connected to water storage tanks and when the water in the heat exchanger get heated up by the superheated refrigerant hot water flow upward through the connecting pipes into the top of the storage tanks and at the same time the cold water from the bottom of the tanks will flow into heat exchangers. The test results show that the concentric heat exchanger produce hot water at a temperature of 45°C and the coil type produced hot water having 40°C. Sheng-shan Bi et al experimentally investigated the performance of domestic refrigerators with SUNISO 3GS mineral oil and TiO₂ nano particle in the working fluids. The result domestic refrigerators are typically to space heating and water heating in minimum constructional maintenances and running cost. A cabin was installed on a domestic refrigerator with condenser coil of refrigerator serving as heating coils inside the cabins. Known quantity of water was heated by the condenser coil (due to convection currents) thereby increasing the overall COP of the refrigerators. Besides, the refrigerator may be used as conventional refrigerator by keeping the cabin door open in case of absence of heat sink. Indicated that the energy consumption of the HFC134 refrigerant using SUNISO 3GS mineral oil and 0.06% mass fraction of TiO₂ nano particle mixture as lubricant reduced the energy consumption by 21.2% when compared to that of HFC134a and POE oil system.

S.C .Kaushiket al presents an investigation of the feasibility of heat recovery from the condenser of a vapor compression refrigeration VCR system through a Canopus heat exchanger CHE between the compressor and condenser component. The presence of the CHE makes it possible to recover the superheat of the discharged vapor and utilize it for increasing the temperature of the external fluid

water removing heat from the condenser. The effect of operating temperatures in the condenser and evaporator for different inlet water temperatures and mass flow rates on the heat recovery output and its distribution over the condensers and CHE the fraction of the condenser heat available through the CHE, the available outlet water temperature and heat recovery factor have all been studied and optimum operating parameter for feasible heat recovery have been ascertained. The parametric results obtained for different working fluids, such as R22, R-12, R-717 & R-500, have been presented. It is found that in general, a heat recovery factors of the order 2.0 and 40% of condensers heat can be recovered through the Canopus heat exchanger for a typical set of operating condition.

M.S.Tandale presented a case study on Super Heat Recovery Water Heater At Worli, Dairy. They used R717 Kirloskar Reciprocating Compressor having a refrigeration system capacity of 270 TR 950KW. The Inlet & Outlet temperature of the Refrigerant are 60°C and 115 °C. The Inlet & Outlet temperatures of the Water are 25 & 70°C. They installed the super heat recovery water heater in the countercurrent mode. The hot water flow rate is 70000 Lit/day. In this system the fuel saving is about 390 IFO/day. The annual saving is near about Rs.23 Lakhs/year. Also the reduction of CO₂ emissions is 330ton/year.

Mukuna and Kilfoi investigated the technical feasibility of a combined refrigerator/heat exchanger and the geyser system. It was concluded that 0.8 % of the total input energy in the geyser was saved in the cycling mode of the refrigerator and continuous mode of the geyser. However, the refrigerator's effectiveness was reduced because refrigerant was not cool enough. Patil and Dange[9] modified a domestic 190 liter refrigerator to recover the waste heat by installing a water tank containing the condenser coils of the refrigerator. Experiment showed that maximum temperature increment was up to 42 degree centigrade. But major drawback with this type of arrangement was that it had no mobility and cannot be used for the domestic purposes.

Sreejith investigated the different types of the compressor oil in a domestic refrigerator with the water cooled condenser. The experiments were done using Polyester oil (POE) oil, HFC134a as the refrigerant and SUNISO 3GS mineral oil. It was concluded that the HFC134a/SUNISO 3GS mineral oil system was working normally and efficiently in the household refrigerator with water-cooled condenser and the energy from consumption of the HFC134a refrigerator using SUNISO 3GS mineral oil as the lubricant reduced the energy consumption of the household refrigerator between 8% and 12% for different loads.

Momin et al. recovered the waste heat from condenser unit of a household refrigerator to

improve the performance of the system by using a thermo siphon. It was found that the after recovering heat from the condenser of the conventional refrigerator, its performance was improved than the conventional refrigerator. It was concluded that the theoretical Cop of the system was more than the system running with air cooled condenser.

M. M. Rahman et al. developed a heat recovery system which recovers the heat from a split air conditioning system. In this case, 65litre heating tank is designed in a way that the copper tube conveying refrigerant is not submerged in the water. The heating recovery tank consists of 2 cylindrical chambers, the inner chamber, is filled with the water, is coiled with the hot refrigerant carrying tube at the outer surfaces. It was found that this heat recovery system improved the compressor efficiency and continuously supplied warm water for domestic purpose. This system rejects less heat to the environment so it is safer in the environmental aspects. Turgul Ogulta discussed the utilization of the waste heat recovery from textile drying process. Sathiamurthi et al. discussed in studies about the waste heat recovery from an air conditioner unit that the energy can be recovered and utilized without sacrificing the comfort level

P. Sathiamurthi and PSS. Shrinivasan discussed in their studies on WHR from an air conditioning unit that the energy can be recovered and utilized without sacrificing comfort level. They have also shown that the system is economically viable. Energy consumption in their system and environmental pollution can still further be reduced by designing and employing energy saving equipment's.

F.N.Yu, K.T.Chan discussed the advanced improved condenser design for air cooled chillers.

O'Brien et al. designed a prototype refrigeration-cum-hot water heating system for domestic use purpose. The system used heat energy rejected from the compressor and condenser of a vapour compression refrigerator by storing it in a heat sink. It was concluded that the system was performing better as the prototype than it did as a hot water heater but it needs to be improve.

R.A Clark *et al.* described the design, model, and testing of an integrated heat recovery system which was designed both to enhance the performance of a refrigerator and simultaneously to provide preheated water for an electric hot water heater. They investigated in that study was to preheat the supply water for a hot water system using refrigerator condenser waste heat. An economic analysis revealed that a savings of 18.33 % on the water heater operating cost was possible. The refig. R- 12 used in that project was not ecofriendly to the ozone layer. The time to increase the temperature of water of 30 °C in the no use test

was 5 days. Thus the things developed in this experimental study did not heat water quickly enough.

Sanmati Mirji presented a multipurpose warming model utilizing the waste heat of domestic refrigerator. The multipurpose model was constructed as an additional part of the refrigerator. It uses the waste heat generated by the refrigerator

and has several possible household uses like food warming, domestic fermentation purpose such as curd making, and fermentation for Indian food. The maximum temperature of the chamber got as high as 51°C and the average temperature was around 40 °C.

4. RESULT AND CONCLUSION

The Design for waste heat recovery was tested with different refrigerant R-242 and R-236me. R-242 refrigerant gave a increase in waste heat recovery of

This paper undertook the review based study in to the COP Enhancement of a Domestic Air Cooled Refrigerator by recovering the heat from Condenser in terms of its background, originality, current status, and the researches. This work has great significant for developing new technologies relates to heat recovery from a domestic refrigerator, in order to get the cooling at low energy cost, no harmful effect to the environment and also having a low initial cost. So attention is required in this area and lot of work has to be done.

International domestic use of energy conference, cape town, South Africa (2011)

5. REFERENCES

Sheng-shan Bi, Lin Shi, Li-li Zhang. Application of nanoparticles in domestic refrigerators. *Applied Thermal Engineering* 28 (2008): 1834–1843.

Romdhane Ben Slama. Water-heater coupled with the refrigerator to develop the heat of the condenser. *International Renewable Energy Congress* November 5-7, 2009; Sousse Tunisia.

S.C.Kaushik, M.Singh., Feasibility and Design studies for heat recovery from a refrigeration

Momin, G.G., Deshmuk-Mulaweh. Design and performance of a thermosiphon heat recovery system. *Applied Thermal Engineering* 26 (2006): 471– 477.

S.S. Hu, B.J. Huang. Study of a high efficiency residential split water-cooled air conditioner. *Applied Thermal Engineering* 25 (2005): 1599–1613.

Shengshan Bi, Kai Guo, Zhigang Liu, Jiangtao Wu. Performance of a domestic refrigerator using TiO₂-R600a nanorefrigerant as working fluid. *Energy Conversion and Management* 52 (2011): 733–737.

Douglas T.Reindl, Todd B. Jekel,“Heat Recovery in Industrial Refrigeration”, *ASHRAE Journal*, August 2007.

Mukuna, J.G., Kilfoil, M., Testing of combined refrigerator/heat exchanger and geyser.