



Over load indicator for motor assembly based on semi automation

G.Kannan¹ V.S.Sivaprakash², R.Senthilkumar², M.Arulmurugan², K.Karventhan².

¹Assistant Professor, ²UG Students,

Department of Mechanical Engineering, Nandha Engineering College, Erode-52,
Tamil Nadu, India.

¹gkannan11@gmail.com, ²sivaerd1996@gmail.com, ²r.senthil193@gmail.com,
²arulmurugan688@gmail.com, ²karve4007@gmail.com

Abstract-The Object of this project is to detect the over load of the motor casing machine and indicate. It is very useful to the all motor industries in order to measure the load of the motor casing machine and also used to avoid the motor casing damage. A load cell can detect objects without physical contact. This object detected in the load cell and given to the amplifier and converting to the small amount of energy convert to the ADC analog to digital converter for measuring overload. We identify the overload through weight scale takes place bottom of the machine. A mechanical arrangement in hydraulic pressing machine the applied force being sensed deforms a strain gauge. As a result, overload indicator can prevent motor from damage by using simpler method.

Index words – Motor casing; Load cell; Hydraulic pressing machine

I.INTRODUCTION

In recent years, many industries attempted to automate everything and remove human element. But, people are still found on many industry today, because humans are still the most programmable, efficient "machines" for most tasks. Most of the industries based on semi-automation. Our project based on half manual and half automation. Whenthe operator place the motor on the fixture and start the process, the over load of the motor casing machine indicates by using weight scale that gives signal to the operator. A load cell is typically an electronic device (transducer) that is used to convert a force into an electrical signal. By a mechanical arrangement, the force can be sensed and deforming a strain gauge. It converts the deformation (strain) to electrical signals.In industrial applications, hydraulic is probably the second most common, and these are utilized to eliminate some problems with strain gauge load cell devices. Every load cell is subject to "ringing" when subjected to abrupt load changes. This stems from the spring-like behavior of load cells. In order

to measure the loads, they have to deform. As such, a load cell of finite stiffness must have spring-like behavior, exhibiting vibrations at its natural frequency. An oscillating data pattern can be the

result of ringing. Ringing can be suppressed in a limited fashion by passive means. Alternatively, a control system can use an actuator to actively damp out the ringing of a load cell. This method offers better performance at a cost of significant increase in complexity. Microcontrollers are play important role in revolutionizing various industries and influencing our day to day life more strongly than one can imagine. Building a complete microprocessor system on a single chip substantially reduces the cost of building simple products, which use the microprocessor's power to implement their function, because the microprocessor is a natural way to implement many products. This means the idea of using a microprocessor for low cost products comes up often. Each part carries costs of money. Even though a product design may require only very simple system, the parts needed to make this system as a low-cost product.

II.LITERATURE SURVEY

[1]. Zhifeng Lou Prediction of Pressing Quality for Press-Fit Assembly Based on Press-Fit Curve and Maximum Press-Mounting Force In order to predict pressing qualities of precision press-fit assembly, press-fit curves and maximum press-mounting force of press fit assemblies were investigated by finite element analysis (FEA). The analysis was based on a 3D Solid works model using the real dimensions of the microparts and the subsequent FEA model that was built using ANSYS Workbench. By verify the FEA results, experiments were carried out a press-mounting apparatus. The results show that the press-fit curves obtained by FEA agree closely with the curves obtained using experimental method. In addition,

the maximum press-mounting force calculated by FEA agrees with that obtained by the experimental method, with the maximum deviation being 4.6%, a value that can be tolerated. The comparison shows that the press-fit curve and max press-mounting force calculated by FEA can be used for predicting the pressing quality during precision press-fit assembly.

Benuzzi and Donzella [2] presented a new method to predict press fit curve. The accuracy of this method can satisfy precision requirements. In addition, the presented method is simpler than FEA method. However, it has its limitations as it can only be utilized in elastic field.

Hu et al. [3] calculated force-time curves by analyzing the working device mechanical structure of hydraulic excavator. According to force-time curves obtained from mechanical structure analysis, the load spectrum was controlled in order to reduce digging resistance. The advantages of that method were verified by practical application, fewer measured points, simpler measured procedures, and lower costs. It is not difficult to see that the method can only be used to control large hydraulic presses with complicated working device and not for low-speed high precision presses. The reason is that the working device of high-speed press should not be complicated.

Martin Bliddt [4]. Models for Bearing Damage Detection in Induction Motors Using Stator Current Monitoring. This paper describes newly models for the influence of rolling-element bearing faults on induction motor stator current. Bearing problems are one major cause for drive failures. Their detection is possible by vibration monitoring of characteristic bearing frequencies. As it is possible to detect other machine faults by monitoring the stator current, a great interest exists in applying the same method for bearing fault detection. After a presentation of the existing fault model, a new detailed approach is proposed. It is based on two effects of a bearing fault: the introduction of a particular radial rotor movement and load torque variations caused by the bearing fault.

Dharmaraj [5] Analysis of interference fit by modeling asperities of surface roughness with axial load capabilities. Interference fitted assemblies are mostly used for their compact design and good load bearing capacity. Interference fits are used in applications where higher loadbearing capacity is required like automotive starter ring to flywheel, timing gears to the crank shaft, motor stator to motor bodies, motor shaft to stators, removal and refitting of a gas turbine impeller, removal and refitting of hollow bolts in electrical generators, assembly of high precision roller bearing etc. They make very preventive assumptions that limit the

geometrical defects and the surface finish. Surface roughness can affect the performance of components and systems in a wide variety of fields including power or torque transmission, fluid sealing, heat transfer. It is progressively common to use a finite element analysis method to adapt the better model to the multifaceted forms of industrial parts. However, the surface geometry of many components and systems is not always identified and cannot always be measured.

YU Lei, BO Min [6] New technology for casing damage prevention and cure of thermal production wells. The casing damage was serious during the thermal production in Liao he Oilfield. Through investigations and researches, reasons for the initial casing damage were determined as follows; higher thermal stress, sand production in oil wells, unfit sub with API round thread and bias buttress thread, low cementing quality, easily appearing casing deformation in cementing annular section, and improper heat insulation tubing and heat insulation measures. The measures adopted are: restress pulling up, substituting N80 casing with bias buttress thread for the common casing, using special cement for thermal production wells and returning to the surface, and utilizing fine heat insulation tubing. After the management, the casing damage in thermal wells was decreased, but the initial casing damage was still heavy. Thus, new techniques were adopted: reducing the casing stress during steam injection using heat stress compensate tool, increasing the deformation resistance using TP100H casing, and solving hoop stress problems of production casings caused by sand production and perforation using TP120TH external upset casing. Through the long-term researches and practices, the initial casing damage rate of thermal wells was reduced.

Thomas G. Habetler [7] Motor bearing damage detection using stator current monitoring. This paper addresses the application of motor current spectral analysis for the detection of rolling-element bearing damage in induction machines. Vibration monitoring of mechanical bearing frequencies is currently used to detect the presence of a fault condition. Since these mechanical vibrations are associated with variations in the physical air gap of the machine, the air gap flux density is modulated and stator currents are generated at predictable frequencies related to the electrical supply and vibrational frequencies. This paper takes the initial step of investigating the efficacy of current monitoring for bearing fault detection by correlating the relationship between vibration and current frequencies caused by incipient bearing failures. This is an important result in the formulation of a fault detection scheme that monitors the stator currents.

SAMUEL S. WATERS [8] Modeling Induction Motors for System Studies Deriving induction motor equivalent circuit parameters task. Parameters for locked rotor and running conditions are supplied with the curves, but neither accurately describes motor response between these conditions. This paper presents a convenient way to derive a set of parameters suitable for the entire operating range and, therefore, suitable for use in induction motor-starting studies. An accurate model is essential to predict available starting torques.

III. WORKING PRINCIPLE

In this project, we are using load cell as a detector. A load cell can detect objects without physical contact. This object detected in the load cell and given to the amplifier. amplifier is converting to the small amount of energy convert to the ADC analog to digital converter. It is an electronic integrated circuit device. It is convert an input analog detail by digital number. It is converting to bits and this detail convert to control unit. It is temper storage device and control unit display the load. Already programmed by the controller in the machine maximum load level. Which is increasing the load against the load limits It is activating the alarm. this is the project is overload indicator for motor industries machine.

A. BLOCK DIAGRAM

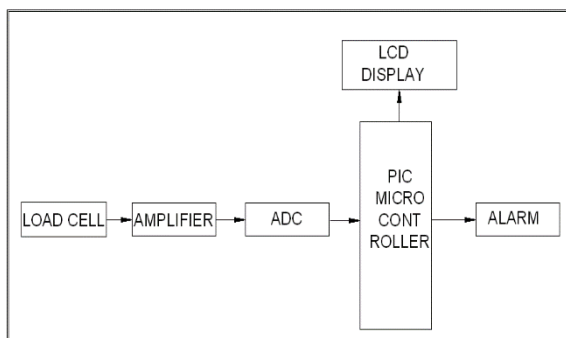

Fig-1:block diagram

B. ADVANTAGE

- Low cost
- Easy implementation
- Low power consumption
- More efficient

IV. BRIEF METHODOLOGY

This project is designed with

- Load cell,
- Amplifier
- ADC
- Pic microcontroller
- LCD display
- Alarm

A. LOAD CELL: A load cell is typically an electronic device (transducer) that is used to convert a force into an electrical signal. Through a mechanical arrangement, the force to be sensed is deforming a strain gauge. The strain gauge converts the deformation (strain) to electrical signals. Normally, a load cell consists of four strain gauges in a Wheatstone bridge configuration, but are also available with one or two strain gauges. The electrical signal output is normally in the order of a few millivolts and requires amplification by an instrumentation amplifier before it can be used.



Fig-2:Load cell

Although strain gauge load cells are the most common, there are other types of load cells as well. In industrial applications, hydraulic (or hydrostatic) is probably the second most common, and these are utilized to eliminate some problems with strain gauge load cell devices. As an example, a hydraulic load cell is immune to transient voltages (lightning) so might be a more effective device in outdoor environments.



Fig-3: piezo-electric load cells

Other types include piezo-electric load cells (useful for dynamic measurements of force), and vibrating wire load cells, which are useful in geomechanically applications due to low amounts of drift. Every load cell is subject to "ringing" when subjected to abrupt load changes. This stems from the spring-like behavior of load cells. In order to measure the loads, they have to deform. As such, a load cell is of finite stiffness and has spring-like behavior, exhibiting vibrations at its natural frequency. An oscillating data pattern can be the result of ringing. Ringing can be suppressed in a limited fashion by passive means. Alternatively, a control system can use an actuator to actively damp out the ringing of a load cell. This method offers better performance at a cost of significant increase in complexity.

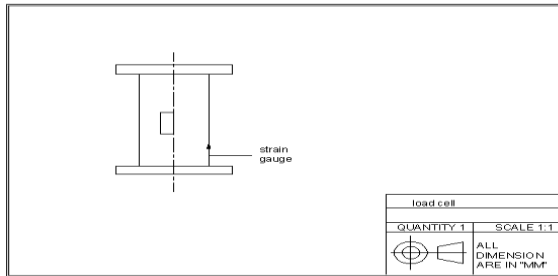

Fig-4:2d diagram of load cell

B. LOAD CELL TYPES

- double ended shear beam
- single ended shear beam
- single column
- multi column
- pancake
- "S" cell

C. APPLICATIONS

- Closed Loop Technology with Load Cells
- electronic crane scales
- finding the center of gravity of an object by weight
- force measurement
- hopper, tank and vessel weighing
- onboard weighing

V. POWERSUPPLY

The ac voltage, typically 220V rms, is connected to a transformer, which steps that ac voltage down to the level of the desired dc output. A diode rectifier then provides a full-wave rectified voltage that is initially filtered by a simple capacitor filter

to produce a dc voltage. This resulting dc voltage usually has some ripple or ac voltage variation. A regulator circuit removes the ripples and also remains the same dc value even if the input dc voltage varies, or the load connected to the output dc voltage changes. This voltage regulation is usually obtained using one of the popular voltage regulator IC units.

A. Block diagram

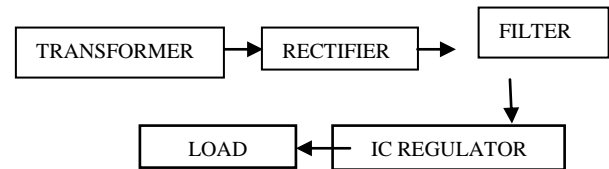

- ✓ Transformer: The potential transformer will step down the power supply voltage (0-230V) to (0-6V) level. Then the secondary of the potential transformer will be connected to the precision rectifier, which is constructed with the help of op-amp. The advantages of using precision rectifier are it will give peak voltage output as DC, rest of the circuits will give only RMS output.

Fig-5:bridge rectifier

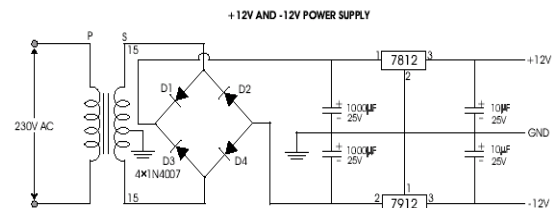
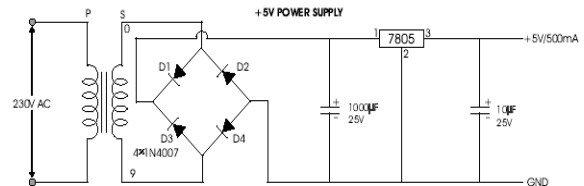

- ✓ Bridge rectifier: When four diodes are connected as shown in figure, the circuit is called as bridge rectifier. The input to the circuit is applied to the diagonally opposite corners of the network, and the output is taken from the remaining two corners. Let us assume that the transformer is working properly and there is a positive potential, at point A and a negative potential at point B. the positive potential at point A will forward bias D3 and reverse bias D4. The negative potential at point B will forward bias D1 and reverse D2. At this time D3 and D1 are forward biased and will allow current flow to pass through them; D4 and D2 are reverse biased and will block current flow. The path for current flow is from point B through D1, up through RL, through D3, through the secondary of the transformer

back to point B. this path is indicated by the solid arrows. Waveforms (1) and (2) can be observed across D1 and D3. One-half cycle later the polarity across the secondary of the transformer reverse, forward biasing D2 and D4 and reverse biasing D1 and D3. Current flow will now be from point A through D4, up through RL, through D2, through the secondary of T1, and back to point A. This path is indicated by the broken arrows. Waveforms (3) and (4) can be observed across D2 and D4. The current flow through RL is always in the same direction. In flowing through RL this current develops a voltage corresponding to that shown waveform (5). Since current flows through the load (RL) during both half cycles of the applied voltage, this bridge rectifier is a full-wave rectifier.

- ✓ IC voltage regulators: Voltage regulators comprise a class of widely used ICs. Regulator IC units contain the circuitry for reference source, comparator amplifier, control device, and overload protection all in a single IC. IC units provide regulation of either a fixed positive voltage, a fixed negative voltage, or an adjustably set voltage. The regulators can be selected for operation with load currents from hundreds of milli amperes to tens of amperes, corresponding to power ratings from milli watts to tens of watts. A fixed three-terminal voltage regulator has an unregulated dc input voltage, V_i , applied to one input terminal, a regulated dc output voltage, V_o , from a second terminal, with the third terminal connected to ground. The series 78 regulators provide fixed positive regulated voltages from 5 to 24 volts. Similarly, the series 79 regulators provide fixed negative regulated voltages from 5 to 24 volts.

B.MICROCONTROLLER: A microcontroller is a complete microprocessor system built on a single IC. Microcontrollers were developed to meet a need for microprocessors to be put into low cost products. Building a complete microprocessor system on a single chip substantially reduces the cost of building simple products, which use the microprocessor's power to implement their function, because the microprocessor is a natural way to implement many products. This means the idea of using a microprocessor for low cost products comes up often. But the typical 8-bit microprocessor based system, such as one using a Z80 and 8085 is expensive. Both 8085 and Z80 system need some additional circuits to make a microprocessor system. Each part carries costs of money. A microcontroller is a Computer-On-A-Chip, or, if you prefer, a single-chip computer.

Fig-6:Block diagram of microcontroller

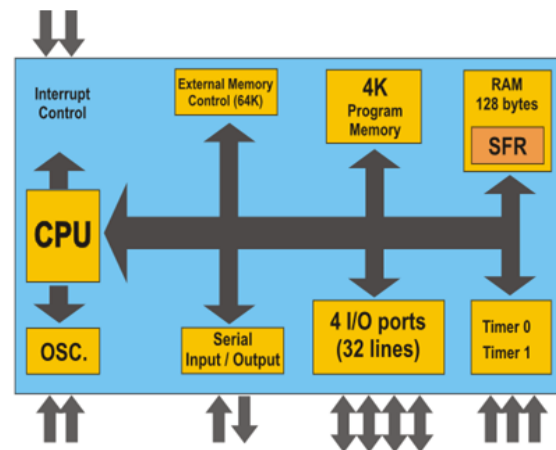

C.PIC: The microcontroller that has been used for this project is from PIC series. PIC microcontroller is the first RISC based microcontroller fabricated in CMOS (complementary metal oxide semiconductor) that uses separate bus for instruction and data allowing simultaneous access of program and data memory. The main advantage of CMOS and RISC combination is low power consumption resulting in a very small chip size with a small pin count. The main advantage of CMOS is that it has immunity to noise than other fabrication techniques. Various microcontrollers offer different kinds of memories.

D. CORE FEATURES:

- High-performance RISC CPU
- Programmable code-protection
- Power saving SLEEP mode
- Selectable oscillator options
- Fully static design

E.ANALOG TO DIGITAL CONVERTER (ADC):

There are two types of analog to digital converter present in this IC. We use 10-bit ADC. The ADC module can have up to eight analog inputs for a device. The analog input charges a sample and hold capacitor. The output of sample and hold capacitor is the input into the converter. The converter then generates a digital result of this analog level via successive approximation. The A/D conversion of the analog input signal results in a Corresponding 10-bit digital number. The A/D module has high and low voltage reference input that is software selectable to some combination of VDD, VSS, and RA2 Or RA3. The A/D module has four registers.

F.CPU TIMING: A machine cycle consists of 6 states. Each state is divided into a phase / half, during which the phase 1 clock is active and phase 2 half. Arithmetic and Logical operations take

place during phase1 and internal register - to register transfer take place during phase 2

G.TRENDS AND DEVELOPMENTS IN MICRO CONTROLLER

- ✓ The manner in which the use of micro controllers is shaping our lives is breathtaking. Today, this versatile device can be found in a variety of control applications. CVTs, VCRs, CD players, microwave ovens, and automotive engine systems are some of these.
- ✓ The micro controller is the most essential IC for continuous process- based applications in industries like chemical, refinery, pharmaceutical automobile, steel, and electrical, employing programmable logic systems (DCS). PLC and DCS thrive on the programmability of an MCU.
- ✓ There are many MCU manufacturers. To understand and apply general concepts, it is necessary to study one type in detail. This specific knowledge can be used to understand similar features of other MCUs.

VI. APPLICATIONS OF MICRO CONTROLLERS

Microcontrollers are designed for use in sophisticated real time applications such as

1. Industrial Control
2. Instrumentation and
3. Intelligent computer peripherals

They are used in industrial applications to control

- Motor
- Robotics

VOLTAGE SIGNAL FROM MICROCONTROLLER OR PC	TRANSISTOR Q1	TRANSISTOR Q2	BUZZER
1	ON	OFF	OFF
0	OFF	ON	ON

VII.ALARM

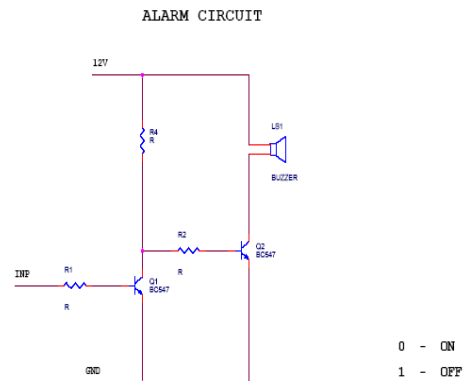

Fig-7:Alarm circuit

A. Buzzer: Buzzer or beeper is a signaling device, usually electronic, typically used in automobiles, household appliances such as a microwave oven, or game shows. It most commonly consists of a number of switches or sensors connected to a control unit that determines if and which button was pushed or a preset time has lapsed, and usually illuminates a light on the appropriate button or control panel, and sounds a warning in the form of a continuous or intermittent buzzing or beeping sound. Initially this device was based on an electromechanical system which was identical to an electric bell without the metal gong (which makes the ringing noise).

B. Circuit description: The circuit is designed to control the buzzer. The buzzer ON and OFF is controlled by the pair of switching transistors (BC 547). The buzzer is connected in the Q2 transistor collector terminal. When high pulse signal is given to base of the Q1 transistors, the transistor is conducting and close the collector and emitter terminal so zero signals is given to base of the Q2 transistor. Hence Q2 transistor and buzzer is turned OFF state. When low pulse is given to base of transistor Q1 transistor, the transistor is turned OFF.

VIII.CONCLUSION

In this paper, we are using load cell as a detector. A load cell can detect objects without physical contact. This object detected in the load cell and given to the amplifier. amplifier is converting to the small amount of energy convert to the ADC analog to digital converter. Already programmed by the controller in the machine maximum load level. Which is increasing the load against the load limits It is activating the alarm. this is the project is overload indicator for motor industries machine

IX.ACKNOWLEDGMENT

We have taken efforts in this project. However, it would not have been possible without the kind

support and help of many individuals and organizations. we would like to extend our sincere thanks to all of them. We would like to express our sincere gratitude to industrial person Mr. Natarajan, general manager for their guidance and giving such attention & time in completing the project. We are highly indebted to our Organization Guide G. Kannan, Assistant professor for their guidance and constant supervision as well as for providing necessary information regarding the project & also for their support in completing the project.

X. REFERENCES

- B. Yazici and G. B. Kliman. "An adaptive statistical time-frequency method for detection of broken bars and bearing faults in motors using stator current "IEEE Trans. Ind. Applicat.. Vol. 35. no. 2. pp. 442-452, Mar. Apr. 1999
- Boutoutaou H, Bouaziz M, Fontaine JF. Modelling of interference fits taking form defects of the surfaces in contact into account. *Material Design* 2011; 32:3692-701
- Croccolo D, DeAgostinis M, Vincenzi N. Static and dynamic strength evaluation of interference fit and adhesively bonded cylindrical joints. *International Journal of Adhesion and Adhesives* 2010; 30:359-66.
- Eyercioglu O, Kutuk MA, Yilmaz NF. Shrink fit design for precision gear forging dies. *Journal of Material Process Technologies* 2009; 209:2186-94
- R. L. Schiltz, "Forcing frequency identification of rolling element bearings," *Sound and Vibration*, pp. 16-19, May 1990
- R. R. Schoen and T. G. Habetler, "Effects of time-varying loads on rotor fault detection in induction machines," in *Con&Rec. 28th Annu. IAS Meeting*, Oct. 1993, pp. 324-330.
- Truman CE, Booker JD. Analysis of a shrink-fit failure on a gear hub/shaft assembly. *Engineering Failure Analysis* 2007;14:557-72
- Zhang Y, McClain B, Fang XD. Design of interference fits via finite element method. *International Journal of Mechanical Science* 2000;42:1835-50.