



## International Journal of Intellectual Advancements and Research in Engineering Computations

### Efficiency improvement in refrigeration system using sub-cooler

Mrs.A.D.Latha<sup>1</sup>, R. Kavinkumar<sup>2</sup>, A.Meezan<sup>2</sup>, R.Naveenkumar<sup>2</sup>, B. Raghuram<sup>2</sup>,

<sup>1</sup>Associate Professor, <sup>2</sup>UG Students,

Department of Mechanical Engineering, Nandha Engineering College, Erode-52,  
Tamil Nadu, India.

adlatha@yahoo.co.in, naveenkumar9696@gmail.com,

**Abstract:-**This work investigates the thermal performance of a thermal battery used in the domestic refrigerator as a sub cooler. A Thermal Energy battery is physical structure used for the purpose of storing and releasing thermal energy. In order to run the compressor without cut-off, the charging mode is used. In the charging mode, refrigeration effect is stored in the thermal battery. In the discharging mode, the refrigeration effect is used to sub cool the refrigerant after the condensation. This study also examines the thermal performance of the sub-cooled ice storage air conditioner under different cooling loads. In the ordinary refrigerator, when the required temperature is attained, the compressor is cut-off and vice versa. During the starting of the compressor the torque needed is high, so the power consumption is high. By using this thermal battery, the compressor need nor to be cut-off and hence the power consumption is also reduced. The system will give more cooling capacity and higher COP by the contribution of the thermal battery used as a sub cooler.

**Keywords:** efficiency, compressor, condensation, evaporation, sub-cooler, COP.

#### I.INTRODUCTION

Refrigeration is the process of moving heat from one location to another in controlled conditions. The work of heat transport is traditionally driven by mechanical work, but can also be driven by heat, magnetism, electricity, laser, or other means. Refrigeration is a science of producing and maintaining heat below that of the surrounding temperature. It means that the heated substance is to be cooled. The heat always flows from the higher temperature to lower temperature. Heat is the major

problem which is to be reduced in all the places. The refrigeration unit is to be employed in such places.

The equipment used to maintain the system at the lower temperature is known as refrigeration system.

#### II.LITERATURE REVIEW

Ming-Chao Huang et al (2006) dealt with the theoretical and experimental investigations of the thermal performance of a thermal battery used in the ice storage air-conditioning system as a sub cooler. The thermal battery utilizes the superior heat transfer properties of two-phase closed thermosiphon and eliminates the drawbacks found in convective energy storage systems. Experimental investigations are first conducted to study the thermal behaviour of thermal battery under different charge temperatures (-5 °C to -9 °C) in which water is used as the energy storage material. This study also examines the thermal performance of the sub-cooled ice storage air conditioner under different cooling loads. Experimental data of temperature variation of water, ice fraction, refrigerant mass flow rate and COP are obtained. The results show that super cooling phenomenon appears in the water and it can be ended when the charge temperature is lower than -6°C.

The system gives 28% more cooling capacity and 8% higher COP by the contribution of the thermal battery used as a sub-cooler. Bilal Ahmed Qureshi (2013) deals that the thermo economic considerations are given to heat exchanger inventory allocation in the vapour compression cycles with mechanical sub cooling. Investigation is made with respect to constant work rate, heat rejection and cooling rates as well as heat transfer in the sub cooler. It was found that no minimum exist for any of

the cost functions with respect to the absolute temperature ratio and the average sub cooling absolute temperature ratio. The derivatives for the integrated sub cooling cycle can be generated from the derivatives of the dedicated sub cooling cycle. It was concluded that the cost optimization of the integrated mechanical sub cooling system is qualitatively the same as the dedicated sub cooling system.

Liang Yang (2010) deals with the energy saving opportunity of supermarket refrigeration systems using sub cooler between the Medium-Temperature (MT) refrigeration system and the Low-Temperature (LT) refrigeration system has been identified in the previous work. The optimal sub cooling control is also discussed. With optimal sub cooler size and sub cooling control, the maximum energy savings of integrated two-temperature supermarket refrigeration system using R404A or R134a as working fluid can achieve 27% or 20%.

Chun-Lu Zhang et al (2015) presents a model-based analysis on the energy saving potential of supermarket HVAC (heating, ventilating, and air-conditioning) and refrigeration systems using multiple sub coolers among the high-temperature HVAC system, the medium-temperature refrigeration system, and the low temperature refrigeration system. The principle of energy reduction is to have the higher COP system generate more cooling capacity to increase the cooling capacity or reduce the power consumption of the lower COP system. The sub cooler could be placed between the medium-temperature and low-temperature systems, between the high-temperature and medium temperature systems, and between the high-temperature and low-temperature systems. All integration scenarios of adding one, two and three sub coolers have been investigated. The optimal sequence of adding sub coolers is also proposed.

#### SUMMARY OF LITERATURE REVIEW:-

The information from the above journals shows the need of instalment of sub cooler in refrigeration system for increase in COP. In the ice storage air conditioning system, the double pipe is used in order to transfer heat. Instead we kept copper coils in close to transfer the heat.

#### III. WORK FLOW PROCESS:-

#### Refrigeration System:

The vapour compression refrigeration system is normally used in fridges. Vapour compression refrigeration system is having four process namely compression, condensation, expansion and evaporation.

#### p-h Diagram of VCRS

The following processes are involved in vapour compression refrigeration system. The sequence of the operation is mentioned in the figure 1.

- (1-2)- Compression process
- (2-3)- Condensation process
- (3-4)- Expansion process
- (4-1)- Evaporation process

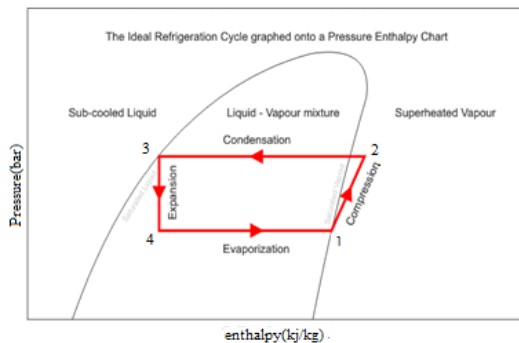

Figure 1 p-h diagram of VCRS without sub cooling

High temperature / low pressure vapour refrigerant comes out from the evaporator and enters to the compressor. The refrigerant is compressed so that the temperature of the refrigerant is increased. The high / temperature high pressure vapour refrigerant enters to the condenser. During the condensation, temperature decreases at the constant pressure process. The high pressure / low temperature liquid refrigerant enters to the expansion valve and the pressure drop occurs. Finally a low temperature / low pressure liquid refrigerant enters to the evaporator. It carries a heat from the heat from the evaporator at the constant pressure process. Vapour compression refrigeration system is an improved type of air refrigeration system in which a suitable working substance, termed as refrigerant, is used. It condenses and evaporates at temperature and pressure close to the atmospheric conditions. The

refrigerant used does not leave the system, but is circulated throughout the system alternately condensing and evaporating.

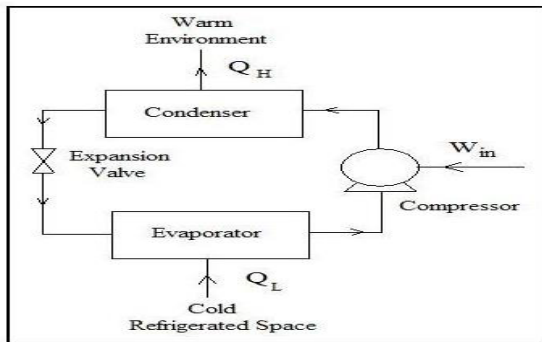

Figure 1(a) VCRS without sub cooling

#### ADDITIONAL SET-UP OF SUB COOLER:

The construction is that the copper tubes are wound into the rectangular box with both sides of projected copper tubes. These both sides are the charging and discharging modes of the sub-cooler. The refrigerant flowing from the condenser is split into two ways using the T-Joint and the refrigerant flowing tube connected to the expansion valves and then to the respective charging and discharging modes. In the charging mode the refrigerant flowing tube is connected directly to the compressor without entering the sub-cooler set up. In the discharging mode the refrigerant flowing tube is connected to the evaporator after entering the sub-cooler set up. The copper tube which is present inside the rectangular box is closed at the both ends. It is filled with refrigerant. The rectangular box is filled with water. The normal refrigerant flow tubes are wound over the projected copper tubes at both the ends. These wound copper tubes are welded using gas welding with the projected copper tubes so that the heat transfer will occur more effectively. The rectangular box is closed at both the ends. The schematic diagram of sub-cooler fixed in refrigerator is shown in Figure.

#### IV. WORKING PRINCIPLE OF SUBCOOLER:

The coefficient of performance in refrigeration is achieved by setting up the sub cooler. The sub cooler setup consists of evaporator, copper tube wound inside the rectangular box. The

refrigerant used here is R134a. The sub cooler setup consists of charging and discharging modes.

#### p-h Diagram of VCRS with sub cooling

Sub cooling is the temperature of a liquid or solid below its saturation temperature. Figure 2 shows the sub cooling process (3'-4'). Due to the sub cooling the refrigeration effect is increased as shown in the p-h diagram.

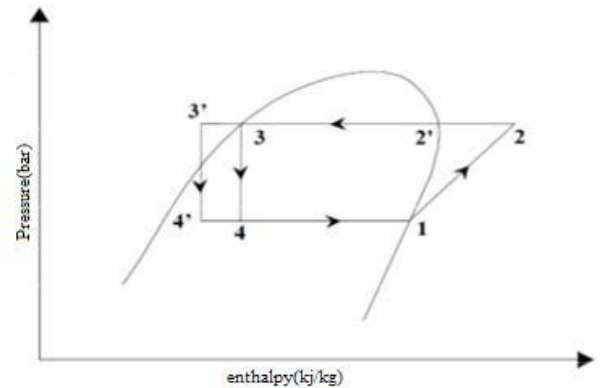

Figure 2 p-h diagram of VCRS with Sub cooling

When the VCRS system is assisted with sub cooling process, the length of the condensation process will be extended and the evaporation process line also extended. Thus the refrigeration effect is increased with respect to constant work done which leads to increase in COP.

In the charging mode, the refrigerant flows over the sub cooler setup and cools the water inside the rectangular box. The water inside the rectangular box is converted into ice. This ice cools the refrigerant which is flowing through the copper tubes inside the rectangular box. Since the refrigerant which is inside the copper tube becomes cool and it is converted into liquid. During the discharging mode, there will be the load so that the refrigerant is made to flow through the discharge tube. Therefore the refrigerant which is flowing through the discharge tube gets cooled and heat is transferred to the copper tube which is wound inside the rectangular box. The refrigerant which is flowing inside the copper tube gets heated and is converted into vapour state. Thus the refrigerant flowing through the copper tube in the rectangular box performs thermosiphon effect which is the process of cooling and evaporating. The two modes charging mode and discharging mode is operated by the direction control valve. The sub

cooling setup is fixed between the condenser and evaporator. In the charging mode, the refrigerant coming from the condenser flows through the sub cooler setup and then directly to the compressor whereas in the discharge mode the refrigerant coming from the condenser enters the sub cooler setup and then to the evaporator. The refrigerant which is flowing through the charging and discharging modes enters through the expansion valve. Thus the increase in cooling is achieved by using this kind of sub cooler.

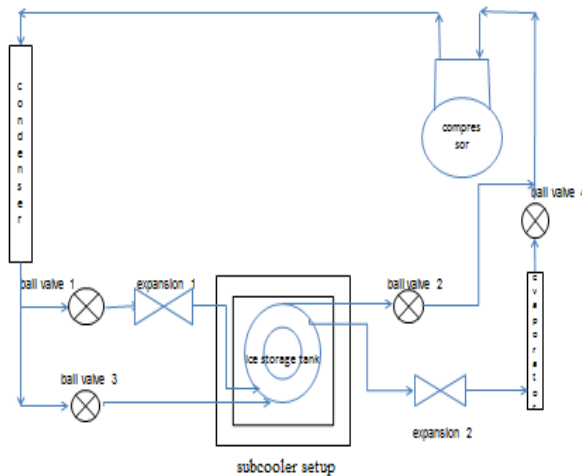

Figure 2(a) VCRS with Sub cooling

## V. DESIGN CALCULATION

Design description

$Q_1$  =Input power (100 watts i.e. given in the compressor name plate) in kW

$Q_2$  =Amount of heat rejected by the refrigerant when sub cooling in kW

$Q_3$  =Amount of heat should be absorbed by the water to sub cool the refrigerant in kW

$m$  =Mass flow rate of the refrigerant in kg/s

$h$  =Enthalpy in kJ/kg

$T$  =Temperature of the refrigerant in °C

$t$  = Temperature of the water in °C

$m_w$  = Mass flow rate of the water in kg/s

$U$  =Specific volume of water in m<sup>3</sup>/kg

$v$  =Volume flow rate in m<sup>3</sup>/s

$V$  =Volume of the water filled in m<sup>3</sup>

$d$  =Diameter of the copper tube in m

$A$  =Heat transfer area of the copper tube in m<sup>2</sup>

$h_o$  =Heat transfer coefficient of copper in W/m<sup>2</sup>K

$p$  =Pressure of the refrigerant in bar

$s$  = Entropy of the refrigerant in kJ/kg K

$C_r$  =specific heat of refrigerant in kJ/kg K

$C_w$  = specific heat of water in kJ/kg K

Sub cooling coil length calculation

The diameter of the copper tube = 12mm

Take heat transfer coefficient of copper as 450 W/m<sup>2</sup>K

$Q_1 = h_o A (\Delta T) kW$

$\Delta T$  =subcooling temperature 7 °C, W.K.T

$Q_1 = 100 \text{ watts}$

Take length of copper tube = 1.5m

$Q_1 = 450 \times 3.14 \times 12 \times 10^{-3} \times 1.5 \times 7 = 178.038 \text{ watts}$

This is not desirable then Take  $L = 1.2 \text{ m}$

$Q_1 = 450 \times 3.14 \times 12 \times 10^{-3} \times 1.2 \times 7 = 142.4304 \text{ W}$

This is also not desirable

Take  $L = 1 \text{ m}$

$Q_1 = 450 \times 3.14 \times 12 \times 10^{-3} \times 1.0 \times 7$

$Q_1 = 118.692 \text{ W}$ , Nearly equals to 100 watts

So the length of copper tube as 1m for the subcooler

## VI. CONCLUSION AND FUTURE SCOPE

This work provides a thermal battery allowing operation of charge, discharge and simultaneous charge and discharge modes. Application of thermal battery as a sub cooler in the refrigerator is demonstrated. The sub cooled ice storage refrigeration system can manually adjust the refrigerant mass flow rates at the charge and discharge heat exchangers, depending upon the energy contents of charge and discharge sides. In addition to providing an enhanced COP technology through sub cooling of high temperature condensate refrigerant, it also balances the cooling load to permit the outdoor unit operating at full load condition. At present this work is completed by circulating the copper tubes into spherical shape to perform thermosiphon effect. Thermosiphon is a physical effect and refers to a method of passive heat exchange based on natural convection, which circulates a fluid without the necessity of a mechanical pump. Thermosiphoning is used for circulation of liquids and volatile gases in heating and cooling applications, such as heat pumps, water

heaters, boilers and furnaces. The copper tube is filled with refrigerant which cools and evaporates according to the temperatures. In future this is to be replaced by series of straight copper tubes arranged parallel to transfer heat and as to perform thermosiphon effect. By doing so we can also be able to transfer more amount of heat that is there is more heat exchange takes place than the other. The sensors are used instead of manually opening and closing of charging and discharging modes.

issue.05, may2016] "cop enhancement of domestic refrigerator by sub cooling and superheating using shell & tube type heat exchanger"

#### References

- [1] Institut international du froid organisation inter gouvernement le pour le developement du froid 17th inforatory note on refrigerating technologies how to improve energy efficiency in refrigerating equipment
- [2] International journal of refrigeration volume 27, issue 2, march 2004, pages 120–128 thermal performance of cold storage in thermal battery for air conditioning
- [3] International journal of heat and mass transfer volume 41, issues 4–5, February–march 1998, pages 769–783 a study of supercooling phenomenon and freezing probability of water inside horizontal cylinders
- [4] International journal of scientific & engineering research, volume 6, issue 5, may-2015: issn 2229-5518 increasing the efficiency of refrigerator by reduces the losses in evaporator, compressor and condenser.
- [5] International journal of research in aeronautical and mechanical engineering to study the effect of sub-cooling and diffuser on the coefficient of performance of vapour compression refrigeration system
- [6] volume 2, issue 2 (2014) 325-332 issn 2347 - 3258 international journal of advance research and innovation 325 IJARI thermodynamic performance evaluation of multi-evaporators single compressor and single expansion valve and liquid vapour heat exchanger in vapour compression refrigeration systems using thirteen eco friendly refrigerants for reducing global warming and ozone depletion
- [7] Issue 3, vol.1 (january 2013) issn 2249-6149 page 521 effect of sub cooling and superheating on vapour compression refrigeration systems using r-22 alternative refrigerants
- [8] International advanced research journal in science, engineering and technology vol. 2, issue 6, june 2015 enhancement of coefficient of performance by analysis of flow through vapour compression refrigeration cycle using cfd
- [9] elk asia pacific journals – special issue isbn: 978-81-930411-4-7 effect of subcooling in vcrcs as compared to simple vcrcs system
- [10] International journal of engineering research & technology (ijert) issn: 2278-0181 enhancement of cop in vapour compression refrigeration system
- [11] Effect of condenser subcooling of the performance of vapor compression systems: experimental and numerical investigation
- [12] International journal of engineering research and advanced technology (ijerat) issn: 2454-6135 [volume. 02