



## International Journal of Intellectual Advancements and Research in Engineering Computations

### The speed control of BLDC motor is performed by PWM

S.Natarajan<sup>1</sup>, K.Rithika<sup>2</sup>, Pavithra<sup>2</sup>, K.Thenmozhi<sup>2</sup>, P.Srinithi<sup>2</sup>

<sup>1</sup>Assistant Professor, EEE Department, Vel Tech , Avadi, Alamthi Road, Chennai 600062, Tamilnadu, India,

<sup>2</sup>UG Students, EEE Department, Vel Tech , Avadi, Alamthi Road, Chennai 600062, Tamilnadu, India

#### ABSTRACT

This work deals with the utilization of solar photovoltaic (SPV) energy in the brushless DC (BLDC) motor driven water pump. A DC-DC boost converter, used as an intermediate power conditioning unit plays a vital role in efficiency enhancement of SPV array and soft starting of the BLDC motor with proper control. The speed control of BLDC motor is performed by PWM (Pulse Width Modulation) control of the voltage source inverter (VSI) using DC link voltage regulator. No additional control or current sensing element is required for speed control. The behavior of proposed pumping system is demonstrated by evaluating its various performances through MATLAB/simulink based simulation study

**Keywords:** Solar PV, BLDC Motor, Boost Converter, Soft Starting, PWM, VSI, Speed Control.

#### INTRODUCTION

The water pumping has become the most attractive application of solar photovoltaic (SPV) energy particularly in the remote rural areas where power transmission is either almost impossible or uneconomical if possible [1]. In general, a DC-DC converter is employed for maximum power point tracking (MPPT) of a SPV array. A DC-DC buck converter is used in [2] for a permanent magnet DC (PMDC) motor driven centrifugal pump. A PMDC motor although avoids one of the power conversion stage i.e. voltage source inverter (VSI), unfortunately it has low efficiency, high maintenance cost and requires frequent maintenance [3]. On the other hand, a buck converter necessarily calls for a ripple filter at its input resulting in the increased cost and size, hence not adapted.

In this work, a DC-DC boost converter is utilized in MPPT of the PV array. The reasons behind opting this converter are its inherent properties of minimum possible switching stress, high conversion efficiency because of less number

of components, very good switch utilization and elimination of input ripple filter since the input inductor itself acts as a ripple filter [4]. Except three classical DC-DC converters viz. buck, boost and buck-boost converter, all other developed topologies [5] have higher number of components resulting in the efficiency deterioration, increased cost, weight and size. In addition, these converters, including the classical buck-boost converter, suffer from higher stress on their power devices and very poor switch utilization. These issues encourage to use a boost converter for desired task.

The induction motor is widely used machine for water pump because of its robustness, low cost, high efficiency, availability in local markets, and low maintenance cost as compared to the DC motor [3]. However, this motor suffers from complex control requirement and overheating problems, thence not adapted [5].

Therefore, a brushless DC (BLDC) motor, possessing a higher efficiency and reliability than an induction motor, low EMI and noise, no

maintenance [1, 6], is employed in the proposed water pumping system.

A combination of boost converter and BLDC motor is already reported in [7] for water pumping but a closed loop control is used to command the speed of BLDC motor which requires additional current sensing elements and complex control scheme. In the proposed system, since the BLDC motor speed is commanded by pulse width modulation (PWM) of VSI using a DC link voltage regulator, no additional current sensing element and control scheme is used. The BLDC motor drive without any current sensor and closed loop speed control for SPV array fed water pump is also reported in [1, 8-10] but these topologies use the DC-DC converters such as buck-boost converter [8], Cuk converter [1], Luo converter [9] and canonical switching cell (CSC) converter [10], which possess the drawbacks of poor switch utilization, high stress on their power devices and large number of reactive elements [4].

As reported in [11], the boost converter, possessing a bounded MPPT region, causes design constraints on SPV array. Therefore, the SPV array is selected that the MPPT is ensured regardless of weather condition. Moreover, proper selection of the SPV array and the BLDC motor also ensures the optimum design of the boost converter. The continuous conduction mode (CCM) of operation

is adapted for boost converter operation to get the reduced stress on its semiconductor devices and components. The starting inrush current of BLDC motor is also limited and the soft starting is accomplished by proper control of SPV array through MPP operation.

The proposed pumping system, offering simplicity, compactness and cost-effectiveness is designed to operate successfully even at 20% solar irradiance of the standard one. The system is designed, modelled and its performance is analyzed in MATLAB/simulink environment. The various starting, steady state and dynamic behaviours are evaluated, considering the practical operating conditions, which manifests its suitability for waterpump.

## CONFIGURATION OF PROPOSED SYSTEM

Fig. 1 shows a detailed schematic of proposed PV array fed BLDC motor driven water pump. This system constitutes a SPV array, boost DC-DC converter, VSI, BLDC motor and water pump. An incremental conductance (INC) MPPT method is applied for efficiency enhancement of PV array through boost converter operation. On the other hand, the speed control of BLDC motor and electronic commutation are.

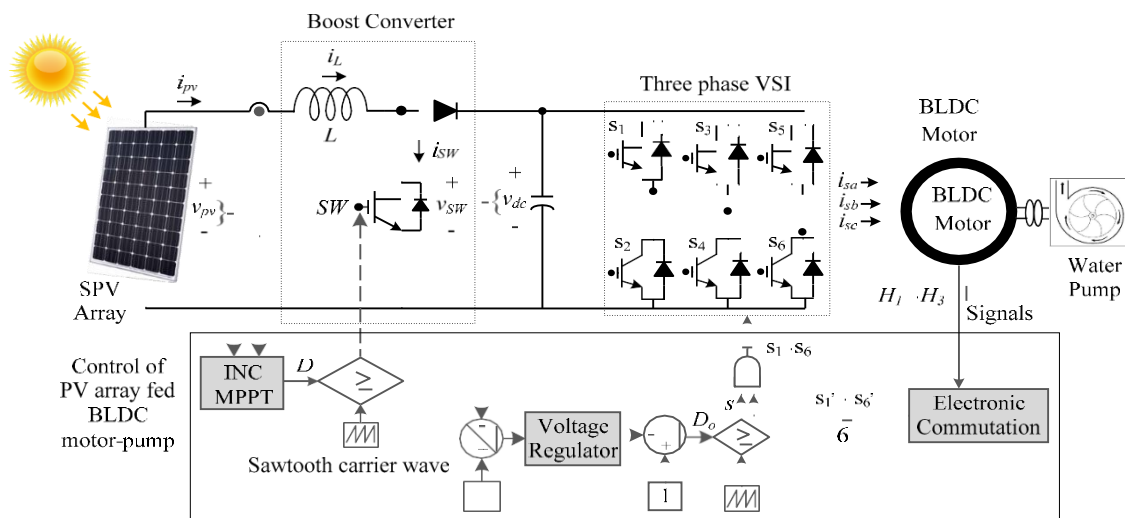

Fig.1 Configuration of PV array fed BLDC motor-pump.

performed by PWM control of the VSI. An inbuilt encoder, mounted on the BLDC motor itself, provides three Hall signals following the rotor position which are further converted into six pulses. Following sections elaborate design and control methodologies of proposed system.

## PROPOSED SYSTEM DESIGN

The design of proposed water pumping system is based on the selection of BLDC motor and pump. A BLDC motor with 1.8 kW power rating is selected, as indicated in Table I, and the other stages viz. PV array, boost DC-DC converter and water pump are accordingly designed. The estimation of various parameters are elaborated in following sections.

### Design of SPV Array

The SPV array of 2.24 kW maximum power rating is selected to feed the BLDC motor - pump of 1.8 kW power rating. The surplus power from SPV array is required to compensate the losses of converters and motor-pump. To estimate the other parameters, SPV array voltage is first considered

according to the rated DC voltage of BLDC motor and optimum design of boost converter. It is selected such that the optimum duty ratio at MPP is at its minimum possible value, which results in a very good switch utilization, reduced voltage and current stress on power devices, reduced current rating of the inductor. A PV module HB-1280, manufactured by HBL Power System Ltd. [12] with peak power of 80 W at standard insolation level of  $1000 \text{ W/m}^2$  is considered to design a SPV array of required capacity. Table II describes the estimation of its parameters.

### Design of Boost DC-DC Converter

The MPP voltage of SPV array,  $v_{pv} = V_{mpp} = 238 \text{ V}$  is boosted to the DC bus voltage of VSI,  $V_{dc} = 310 \text{ V}$ . This offers a minimum duty ratio,  $D$ , resulting in the merits mentioned in previous section. Table III summarizes the estimation of inductor,  $L$  [4] and capacitor,  $C$  [1], where  $f_{sw}$  is the switching frequency of boost converter;  $I_L$  is the average inductor current;  $\Delta I_L$  is ripple contents in the inductor current;

**Table I specifications of BLDC motor**

Power, $P$	1.8 kW
Speed, $N_r$	3000 rpm
DC voltage, $V_{dc}$	310 V
Poles, $P$	4
Inertia, $J$	$3.5 \text{ kg.cm}^2$
Current, $I_s$	5.64 A
Voltage constant, $K_e$	78 V/krpm
Torque constant, $K_t$	0.74 Nm/A
Phase resistance, $R_s$	2.3 $\Omega$
Phase inductance, $L_s$	7.68 mH

**Table II Design of SPV array**

Solar PV Module	
Cells	36
Module voltage	21 V
Module current	5.6 A
Module MPP voltage, $V_m$	17 V
Module MPP current, $I_m$	4.75 A
Solar PV array	
MPP voltage, $V_{mpp} = v_{pv}$	238 V
Power at MPP, $P_{mpp} = p_{pv}$	2240 W
Current at MPP, $I_{mpp} = i_{pv}$	$P_{mpp}/V_{mpp} = 2240/238 = 9.4$ A
Numbers of modules in series, $N_s$	$V_{mpp}/V_m = 238/17 = 14$
Numbers of modules in parallel, $N_p$	$I_{mpp}/I_m = 9.4/4.75 = 1.98 \approx 2$

**Table III Design of boost dc-dc converter**

Parameter	Expression	Data	Value	Selected value
$D$	$V_{dc} \approx v_{pv}$	$v_{pv} = 238V$	0.23	0.23
	$V_{dc}$	$V_{pv} = 310V$		
$L$	$I_L = N_p * I_m$	$D = 0.23$	2.88mH	3 mH
	$L \approx D * v_{pv} / f_{sw} \approx I_L$	$v_{pv} = 238 V$		
		$f_{sw} = 20$ kHz		
		$N_p = 2$		
$f_{sw} \approx I_L$	$I_m = 4.75$ A	$\Delta I_L = 10\%$ of $I_L$		
$C$	$\approx 2 * \approx f \approx 2 * \approx N_r * P$	$P = 4$	309 $\mu$ F	500 $\mu$ F
	$\approx 2 * \approx N_r * P$	$N_r = 3000$		
	$\approx 2 * \approx N_r * P$	rpm		
	$I_{dc} = P_{mpp}/V_{dc}$	$V_{dc} = 310$ V		
	$* C \approx I_{dc} / \Delta V_{dc}$	$P_{mpp} = 2240$ W		
	$6 * \approx * \approx V_{dc}$	$\Delta V_{dc} = 2\%$ of $V_{dc}$		

\* DC bus of VSI comprises the sixth harmonic component of VSI output voltage

$\Delta V_{dc}$  is ripple contents in the capacitor voltage;  $I_{dc}$  is average current flowing through the DC bus of VSI;  $f$  and  $\omega$  are the input voltage frequencies of BLDC motor in Hz and rad/sec. respectively. The poles of BLDC motor are denoted by  $P$ , and speed of the BLDC motor is denoted by  $N_r$ . The values of converter parameters are selected such that the

proposed system performs satisfactorily even at the bad weather condition also.

## Design of Pump

The water pump is designed on the basis of its power- speed characteristics [1, 13] as,

$$K_p = \frac{P}{\omega^3} = \frac{1800}{(2*\pi*3000/60)^3} = 5.8 * 10^{-5} \text{ W}/(\text{rad}/\text{sec})^3 \quad (1)$$

Where  $K_p$  is proportionality constant and  $\omega$  denotes the BLDC motor speed in rad/sec.

## PROPOSED SYSTEM CONTROL

The control techniques used at various stages of proposed water pumping system are divided into following three parts.

### MPPT of Solar PV Array

In order to enhance the efficiency of a SPV array, MPPT is mandatory due to variable weather condition. The proposed system adapts an INC type of MPPT technique [2, 14-15]. This technique is less sensitive to the system dynamics and noise. The direct duty ratio control is used because it offers good stability characteristics and simplicity. The initial duty ratio is set as zero in view of soft starting of the motor. Likewise, the perturbation size is 0.001 in order to get reduced swing around the optimum operating point.

### Electronic Commutation of Brushless DC Motor

The VSI which feeds the brushless DC motor is switched in a predefined sequence to perform the so called electronics commutation [1, 6]. It is a procedure of converting the three Hall signals into the six switching signals,  $s_1$ '- $s_6$ '. The three Hall signals are generated by the encoder, mounted on the shaft, according to the rotor position. The conduction of only two switches at a time results in a reduced conduction losses.

### Speed Control of Brushless DC Motor-Pump

The speed control of BLDC motor-pump is accomplished by PWM switching of VSI while regulating its DC bus voltage. As illustrated in Fig. 1, the reference and sensed DC bus voltage,  $V_{dc}^*$  and  $v_{dc}$  respectively, are compared and the error is passed through voltage regulator which is a PI (Proportional-Integral) controller. Further, the output value of voltage regulator is compared with the maximum possible value of duty ratio i.e. 1 to

get the final duty ratio,  $D_o$ . The comparison of  $D_o$  and a high frequency carrier wave results in a PWM signal, Finally, the PWM switching signals for VSI are generated by modulating  $s_1$ '- $s_6$ ' with  $s$  using AND logic. The duty ratio of the switches of VSI,  $D_o$  varies following the variation in weather condition, resulting in the BLDC motor-pump speed control. This proposed method of speed control completely eliminates the motor current sensing elements and requires only a voltage sensor at the DC link, resulting in a reduced complexity, cost and size.

## SIMULATED RESULTS AND PERFORMANCE ANALYSIS

The proposed water pumping system is simulated in MATLAB environment to demonstrate its starting, steady state and dynamic behavior subjected to the rapid variation in weather conditions. This performance, presented in Figs. 2-7, includes the performance of solar PV array, boost DC-DC converter and brushless DC motor-pump as elaborated in the following sections. This performance analysis manifests the superior performance of proposed water pumping system.

### Starting and Steady State Performances of Proposed

#### System at 1000W/m<sup>2</sup>

The starting and steady state behavior of various indices of solar PV array, boost DC-DC converter and brushless DC motor-pump are presented in Figs. 2-4 respectively. As shown in Fig. 2, MPP of the SPV array is properly tracked, hence the SPV array is operating at 2240 W. The boost converter is operating in CCM and the DC bus voltage of VSI is regulated at 310 V as shown in Fig. 3. The peak

voltage stress on the switch is 310 V. Similarly the peak current stress on the switch is observed as 9.5 A. Fig. 4 exhibits that the motor current is limited to permissible range at starting and the motor is running at its rated speed of 3000 rpm, pumping the water with full capacity.

**Dynamic Performance of Proposed System**

To demonstrate the dynamic behavior of proposed water pumping system, the irradiance is increased from 200 W/m<sup>2</sup> to 1000 W/m<sup>2</sup> and

reduced to 200 W/m<sup>2</sup> as shown in Fig. 5. The SPV array, irrespective of variation in irradiance, operates at its MPP. The boost converter operates in CCM and the DC bus voltage is regulated at 310 V as shown in Fig. 6. Following the variation in solar irradiance, speed of the motor is controlled and the motor draws corresponding current as presented in Fig. 7. The speed of motor at 200 W/m<sup>2</sup> is observed as 1310 rpm, a sufficient speed to pump some amount of water.

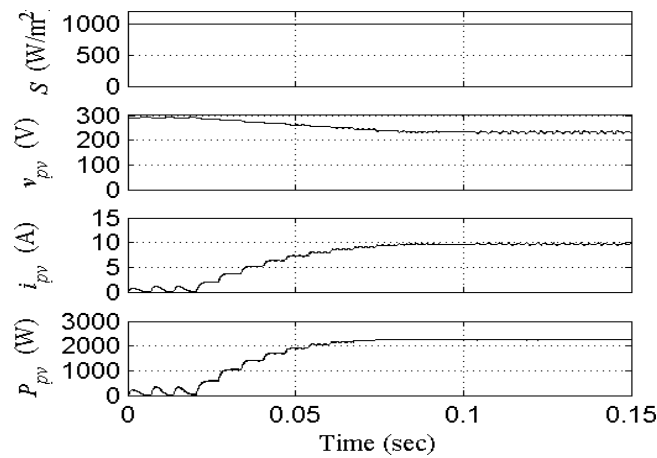

**Fig.2 Starting and steady state performances of solar PV array**

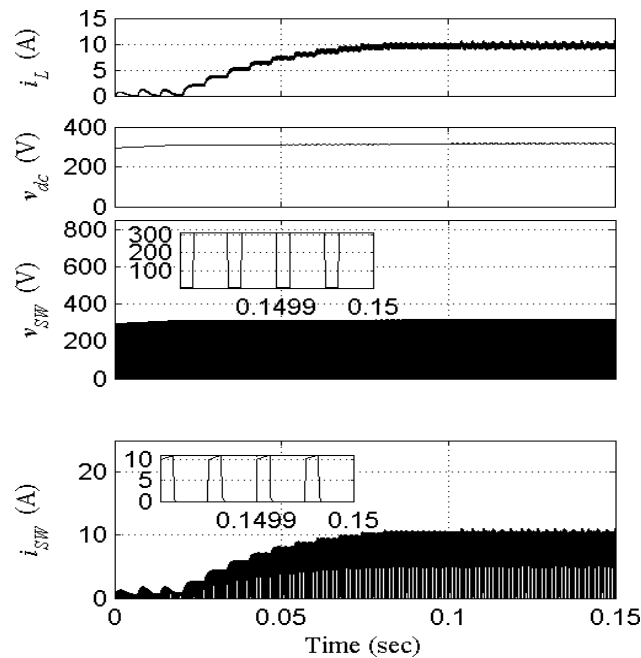

**Fig.3 Starting and steady state performance of boost DC-DC converter**

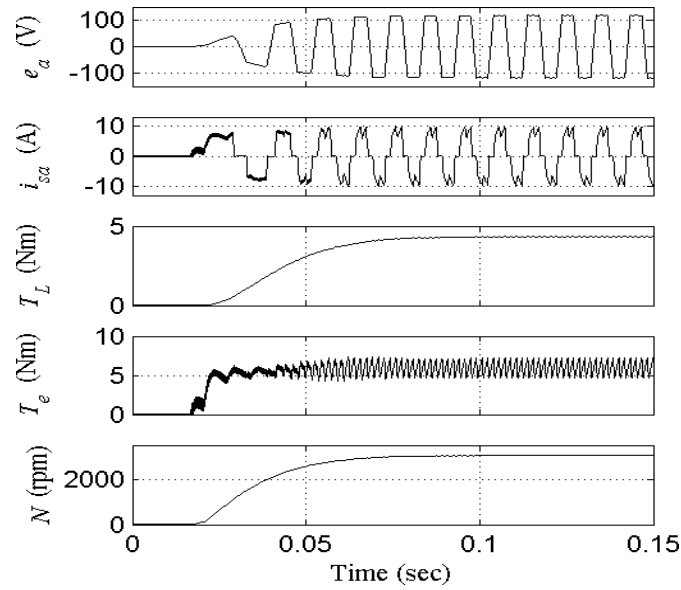

**Fig.4 Starting and steady state performance of brushless DC motor-pump**

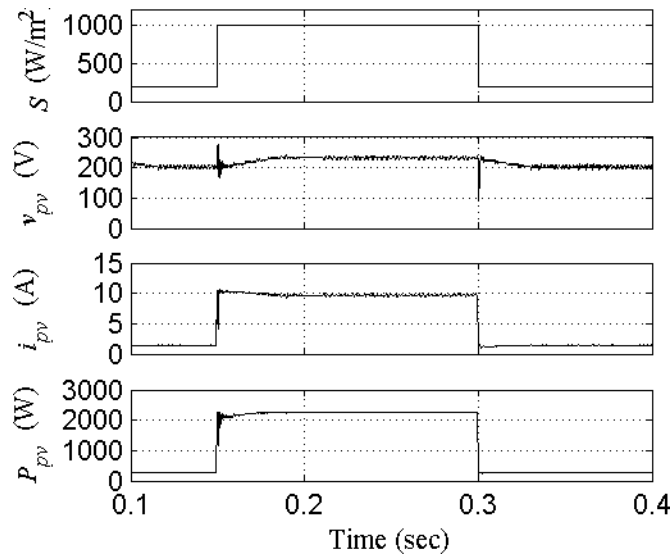

**Fig.5 Dynamic performance of solar PV array**

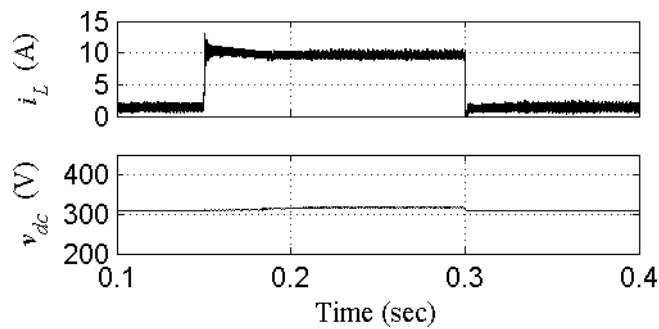

**Fig.6 Dynamic performance of boost DC-DC converter**

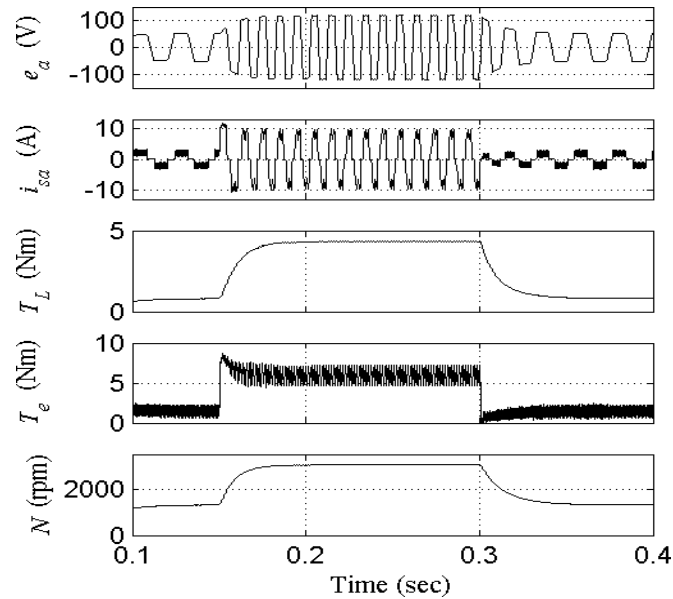

**Fig.7 Dynamic performance of brushless DC motor - pump**

## CONCLUSIONS

The SPV Array fed boost converter based BLDC motor driven water pump has been proposed and its suitability has been demonstrated by analyzing its various performance indices using MATLAB based simulation study. A simple, efficient and economical method for speed control of BLDC motor has been suggested, which has offered absolute elimination of current sensing elements. The proper selection of

SPV array has made the boost converter capable of tracking MPP irrespective of weather conditions. An optimum design of the boost converter has been presented. The safe starting of brushless DC motor has been achieved without any additional control. The desired performance of proposed system even at 20% of standard solar irradiance has justified its suitability for solar PV based water pumping.

## REFERENCES

- [1]. R. Kumar and B. Singh, "Solar PV array fed Cuk converter-VSI controlled BLDC motor drive for water pumping," 6th IEEE Power India Int. Conf. (PIICON), 5-7, 2014, 1-7.
- [2]. M. A. Elgendy, B. Zahawi and D. J. Atkinson, "Assessment of the Incremental Conductance Maximum Power Point Tracking Algorithm," IEEE Trans. Sustain. Energy.,4(1), 013, 108-117.
- [3]. J.V. Mapurunga Caracas, G. De CarvalhoFarias, L.F. Moreira Teixeira and L.A. De Souza Ribeiro, "Implementation of a High-Efficiency, High-Lifetime, and Low-Cost Converter for an Autonomous Photovoltaic Water Pumping System," IEEE Trans. Ind. Appl., 50(1), 2014, 631-641.
- [4]. N. Mohan, T. M. Undeland and W. P. Robbins, Power Electronics: Converters, Applications and Design, 3rd ed. New Delhi, India: John Wiley & Sons Inc.2010.
- [5]. M. H. Rashid, Power Electronics Handbook: Devices, Circuits, and Applications," 3<sup>rd</sup>ed. Oxford, UK: Elsevier Inc.2011.
- [6]. B. Singh and V. Bist, "A BL-CSC Converter-Fed BLDC Motor Drive With Power Factor Correction," IEEE Trans. Ind. Electron., 62(1), 2015, 172-183.
- [7]. M. Ouada, M.S. Meridjet and N. Talbi, "Optimization Photovoltaic Pumping System Based BLDC Using Fuzzy Logic MPPT Control," Int. Renew. Sustain. Energy Conf. (IRSEC), 7-9, 2013, 27-31.
- [8]. Rajan Kumar and Bhim Singh, "Buck-boost converter fed BLDC motor drive for solar PV array based water pumping," in IEEE International Conference on Power Electronics, Drives and Energy Systems

- (PEDES), 16-19 Dec. 2014,pp.1-6.
- [9]. Rajan Kumar and Bhim Singh, "Solar photovoltaic array fed Luo converter based BLDC motor driven water pumping system," in 9th International Conference on Industrial and Information Systems (ICIIS), 15-17 Dec. 2014,pp.1-5.
- [10]. Rajan Kumar and Bhim Singh, "Solar photovoltaic array fed canonical switching cell converter based BLDC motor drive for water pumping system," in Annual IEEE India Conference (INDICON), 11-13 Dec. 2014,pp.1-6.
- [11]. M. H. Taghvaei, M. A. M. Radzi, S. M. Moosavain, Hashim Hizam and M. Hamiruce Marhaban, "A Current and Future Study on Non-isolated DC-DC Converters for Photovoltaic Applications," *Renew. Sustain. Energy Rev.*, 17, 2013, 216-2273.
- [12]. StandardSolarPVModuleSpecifications[Online]Available:<http://www.hbl.in/brochures%20pdf/SOLAR%20MODULE-Broucher.pdf>
- [13]. W.V. Jones, "Motor Selection Made Easy: Choosing the Right Motor for Centrifugal Pump Applications," *IEEE Ind. Appl. Mag.*, vol.19, no.6, pp.36-45, Nov.-Dec.2013.
- [14]. Boualem Bendib, Hocine Belmili and Fateh Krim, "A survey of the most used MPPT methods: Conventional and advanced algorithms applied for photovoltaic systems," *Renew. Sustain. Energy Rev.*, 45, 2015, 637- 648.
- [15]. M.A.G.de Brito, L.Galotto, L.P.Sampaio, G.de Azevedo e Melo and Canesin, "Evaluation of the Main MPPT Techniques for Photovoltaic Applications," *IEEE Trans. Ind. Electron.*, 60(3), 2013, 1156-11673.