



International Journal of Intellectual Advancements and Research in Engineering Computations

Implementation of students attendance monitoring system using RFID and GSM

Mahendran P¹, NaveenKumar K², Prasanth G³, Soundharya M S, Vidhyashree S⁴

¹Assistant Professor, Department of ECE

²PG Scholar, Department of ECE, K.S.R. College of Engineering, Tiruchengode-637215.

ABSTRACT

In Schools, Colleges, Institutions there is a problem of irregularity of students that affects the overall academic performance of Students. Currently, in some institutions, the attendance is taken by calling or signing in registers i.e. very time consuming and space consuming. So, in this paper the authors wants to present an RFID and GSM Based Attendance Monitoring System using door locking/unlocking system. In this paper RFID Reader receives the data from RFID tag. Each student is issued an RFID tag. A predefine program is stored in this tag for Student ID. Whenever the Student enters into the institution, he has to swept that RFID tag near RFID Reader that is attached externally to our microcontroller based embedded system. At that moment the reader will checks whether the information of the students is correct or not and then it will decide whether the student is permitted to enter or leave. If the student's information is correct then the door of the institution is opened and he will be permitted to enter inside. After some time, the door would be closed and if the information is not correct then he will not permit inside, as the door will not get unlocked .The Student Details will be indicated on the LCD display and send through GSM SIM 300 Modem to parents to display whether the student is present or not. The designed system provides an acknowledgement to the parents whose attendance has been taken.

Keywords: Door locking/ unlocking system, RFID, GSM SIM 300 modem, 8051 Microcontroller, Fingerprint sensor, Relay, AVR Studio.

INTRODUCTION

In recent years, there is a problem of irregularity of students which may affect the student growth in education. This problem is also faced by parents as they don't know whether their ward is attending the school/college or not. Today, in most Institutions teachers take attendance by calling out names or passing a sheet of paper. Both ways have respective drawbacks. First way of taking attendance is time consuming as well as prone to errors and in second case there are chances of having proxy attendance. So RFID and GSM Based Attendance Monitoring System using door locking/unlocking system aims at removing

all these problems and drawbacks. In this System, Each student is assigned a RFID Tag that has a unique ID. Whenever the Student enters the college premises, he will swipe that card near the Reader. The Reader will read the Student's Information and if that information is correctly matched then the door of the Institution is opened and student is permitted to enter. After some time the door gets closed automatically and at the same time message will get displayed on LCD indicating that at the attendance has been taken. At the same moment SMS will be send to the parents mobile via GSM SIM 300 Modem to alert the parents that their ward is attending the college/school. Here Microcontroller is used for controlling the events.

Author for correspondence:

Department of ECE, K.S.R. College of Engineering, Tiruchengode-637215.

This System is implemented using RFID Card Reader, AT89S52 Microcontroller, RFID Tags,

Driver unit for door/locker control, GSM SIM 300 Modem and LCD display.

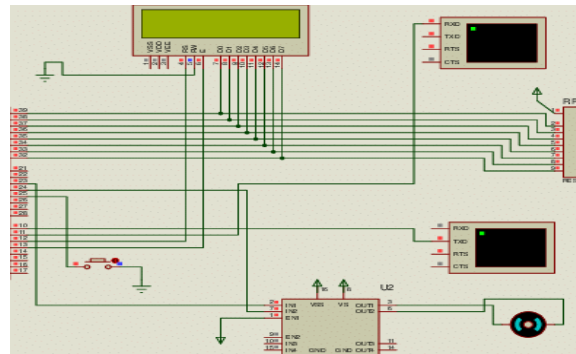

Circuit diagram of RFID and GSM based attendance monitoring system

WHAT IS 8051 MICROCONTROLLER

In 1981, Intel Corporation introduced an 8-bit microcontroller called the 8051. The 8051 is an 8-bit processor, meaning that the CPU can work on only 8 bits of data at a time [1-5]. There are various family members of 8051 but in this paper we use AT89S52 Microcontroller. The controller is ATMEL'S AT89S52 which is a 40 pin

microcontroller with 32 input/output lines. The microcontroller communicates with the RFID Reader and GSM SIM 300 Modem using RS232 protocol for which MAX232 IC is required. This IC is used for converting the CMOS (0-5V) voltage levels into RS232 (plus/minus 12V) voltage levels.

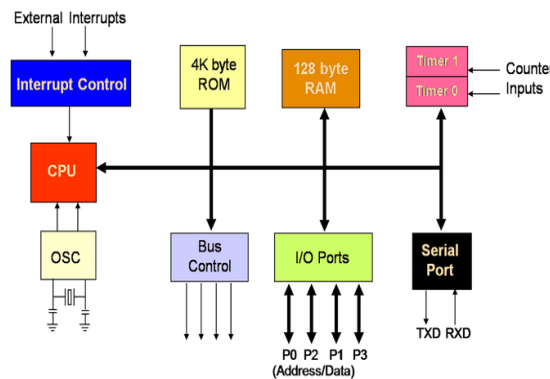

THE 8051 BLOCK DIAGRAM

WHY AT89S52 IS USED

The AT89S52 is a low power, high performance CMOS 8 bit microcontroller with 8K bytes of in-system programmable Flash Memory. This AT89S52 is manufactured by ATMEL Company. Reprogramming is to be done by the on

chip Flash feature. The features of AT89S52 are: 8K bytes of Flash, 256 bytes of RAM, 32 I/O lines, Watchdog timer, two data pointers, three 16-bit timer/counters, a six-vector two level interrupt architecture, a full duplex serial port, on-chip oscillator, and clock circuitry.



WHAT IS GSM SYSTEM

GSM (Global System For Mobile Communication) is widely used digital mobile telephony system. It works on TDMA (Time Division Multiple Access) approach and it is used in three digital wireless telephony technologies

(TDMA, GSM and CDMA). Today, more than 690 mobile networks provide GSM services across 213 countries and GSM represents 82.4% of all global mobile connections. According to GSM World, there are now more than 2 billion GSM mobile phone users worldwide.

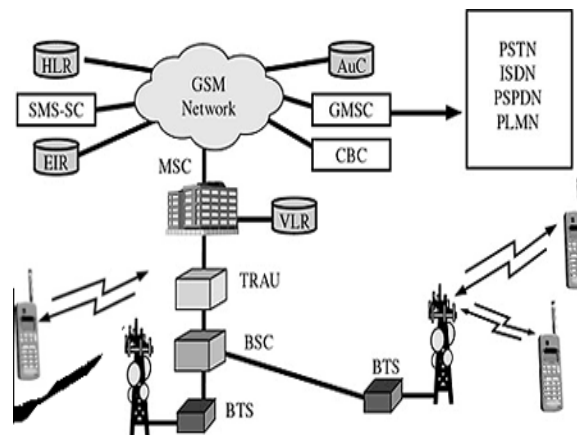

BLOCK DIAGRAM OF GSM ARCHITECTURE

WHAT IS GSM MODEM

The specialized feature of this modem is that it also accepts a SIM card, and just like a mobile phone, it operates over a subscription to a mobile operator. So, it just looks like a mobile phone. It provides various applications like SMS for sending and receiving messages over the modem. Here the

charges are to be taken for sending and receiving messages as done on a mobile phone [6, 7]. All these tasks are performed on a GSM modem and that modem must support an “extended AT command set” for sending/receiving SMS messages.



WHY GSM SIM 300 MODEM WITH RS232 IS USED

- It is a trib and GSM modem (900 MHZ, 1800 MHZ, 1900 MHZ). A facility of serial TTL direct interface to microcontroller is available.
- It also controls through Standard AT commands.
- It comes with a standard RS232 interface which can be used to easily interface the modem to micro controllers and computers
- For better reception, there is an onboard wired antenna is there.
- By default, the serial baud rate of SIM 300 is 9600. It also provides an adjustable baud rate from 1200 to 115200 bps.
- A low power consumption of 0.25 A during normal operations and around 1 A during transmission.
- Operating Voltage: 7 – 15V AC or DC (board has onboard rectifier).
- In GSM Modem SIM (Subscriber Identity Module) is to be inserted inside it. Through this modem, SMS will be sent to the parent's mobile indicating that the Student is attending the college/school or not. SMS, commonly referred as "Text messaging" is a service for sending short messages up to 160

characters to mobile devices including Cellular Phones, Smart phones.

WHAT IS RFID

RFID (Radio Frequency Identification). It is a technology that uses radio waves to transfer data from an electronic tag, called RFID tag or label, attached to an object, through a reader for the purpose of identifying and tracking the object. The first School in USA to introduce RFID technology was Spring Independent School District near Houston, Texas in 2004, it gave 28,000 students RFID badges to record when students got on and off school buses. This was expanded in 2008 to include location tracking on school campuses. According to different needs and requirements there are different types of Attendance System. Like,

- Biometric Attendance System
- Magnetic Stripe Attendance System
- Barcode Attendance System and
- RFID Attendance System.

RFID Reader (also called as RFID Interrogator)

It is a low frequency Reader operates at 13.56 MHz is used to detect the tag. It can detect the presence of RFID tags as well as send and receive data and commands from RFID tags.

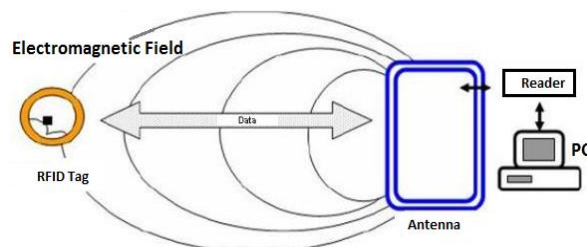

FUNCTIONING PRINCIPLE OF RFID SYSTEM

RFID TAG (also called as Transponders)

There are two types of RFID tags,

- (i) Passive Tags (Does not have battery) and
- (ii) Active Tags (Have Battery on the board). The 18 digit number tag is inbuilt on the Passive Tag, whereas in Active Tag, one can either read /write from/to the tag. We have used passive tag.

Whenever the tag is swapped near the reader, because of the induced mutual inductance energy, data is transferred to reader. From the Reader, the data is transferred to the microcontroller. Then attendance is taken by the microcontroller if the tag is proved to be authenticated.



RFID TAGS

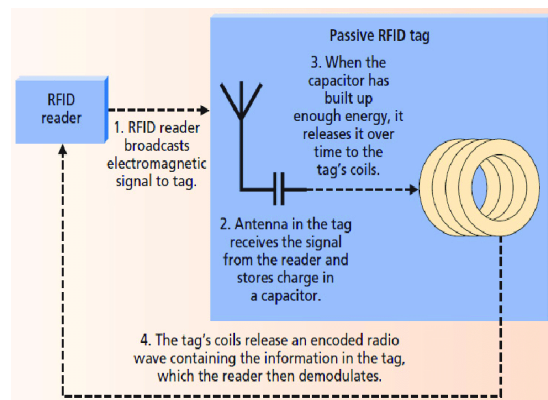

Simplified view of data transfer in a low frequency passive rfid tag

FINGERPRINT SENSOR

Automated fingerprint based attendance system has replaced the annoying manual registers in many organizations. Fingerprint attendance system prevents fraud recording of working hours that employees otherwise used to do with manual paper attendance system. Fingerprint scanners are

security systems of biometrics. They are used to unlock doors and in other security applications. Every fingerprint is different from any other in the world. Because there are countless combinations, fingerprints are much used for identification.



FINGER PRINT SENSOR

RELAY

A relay is an electrically operated switch. Many relays use an electromagnet to operate a switching mechanism mechanically, but other operating principles are also used. The first relays were used in long distance telegraph circuits. When voltage is supplied to the primary circuit, current flows through the coil winding to ground. Whilst doing so, a magnetic field develops around the primary coil. As the magnetic field builds, it pulls together the switch contact in the secondary circuit, thus supplying current to the component being operated. When the relay is switched off the magnetic field is removed and the sprung plate returns the switch to the open circuit position, thus switching off the power.

SOFTWARES USED

AVR Studio is an Integrated Development Environment (IDE) for writing and debugging AVR Applications in Windows 9x/ME/NT/2000/XP/VISTA/7/8 Environments. **AVR Studio 4** has a modular architecture, which allows even more interaction with 3rd party software vendors.

AVR studio is an Integrated Development Environment (IDE) by **ATMEL** for developing applications based on 8-bit AVR microcontroller. Prior to installation of **AVR Studio** you have to install the compiler WinAVR.



PROGISP is the software used to load the HEX file on to the target chip. KEIL Microvision is the software to create HEX file using C code or Assembly language. The In-system programming (ISP) programming method is functionally performed through SPI, plus some twiddling of the Reset line. As long as the SPI pins of the AVR aren't connected to anything disruptive, the AVR chip can stay soldered on a PCB while

reprogramming. All that's needed is a 6-pin connector and programming adapter. This is the most common way to develop with an AVR. The In-system programming (ISP) programming method is functionally performed through SPI, plus some twiddling of the Reset line. As long as the SPI pins of the AVR aren't connected to anything disruptive, the AVR chip can stay soldered on a PCB while reprogramming.

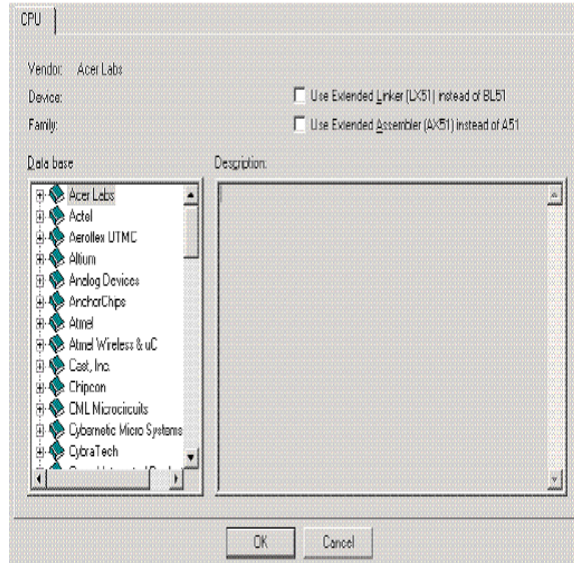

WINDOW FOR CHOOSING TARGET DEVICE

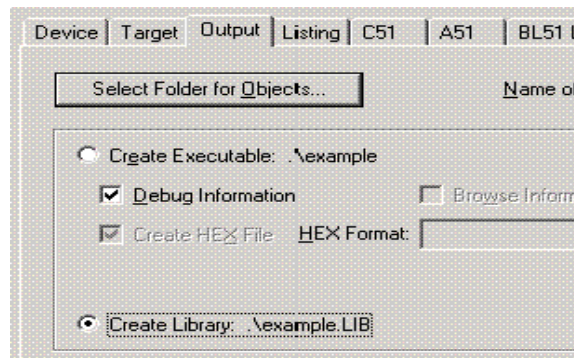

PROJECT OPTIONS DIALOG

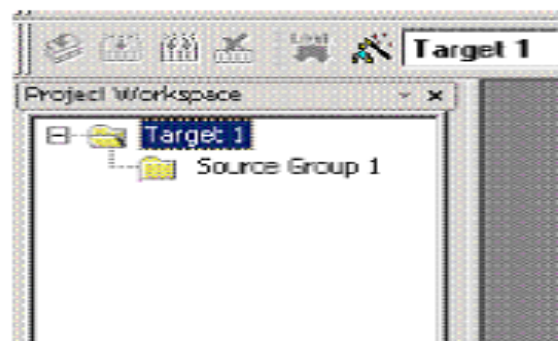

PROJECT WORKSPACE PANE

RFID and fingerprint based attendance management system was developed to provide a faster, more secure, and more convenient method

of user verification than passwords and tokens can provide for a reliable personal identification.

WORKING OF PROPOSED SYSTEM

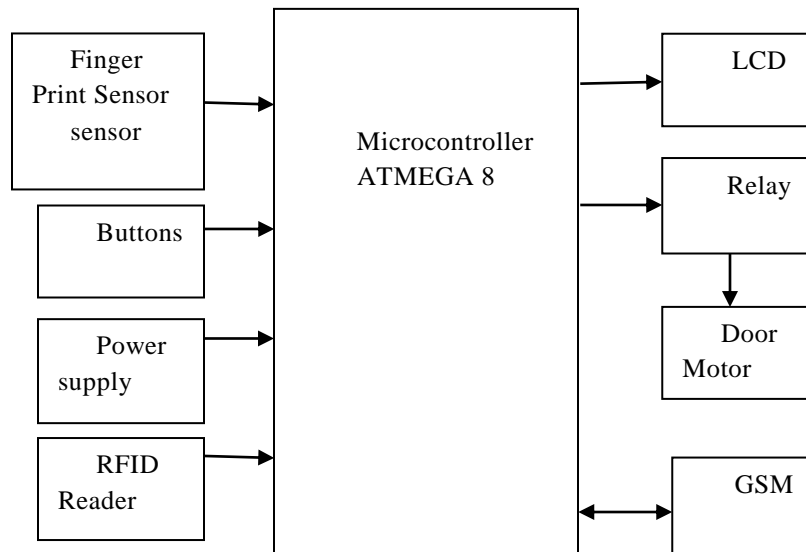

BLOCK DIAGRAM OF PROPOSED SYSTEM

In this System, a radio frequency wave is to be sent from RFID Reader to the tag and the tag sends its stored data to the reader. The reader sends out a power pulse to the antenna lasting for about 50 Ms. The system has two antennas, one is situated on the tag and another on the reader. Then the stored data passes from Reader to microcontroller and Students Information get displayed on LCD. So, the attendance of the students were maintained and their status updated to the parents via GSM. GSM (Global System for Mobile Communication) network is used to send SMS to parents about the student's detail. We have tried to extend this application by the use of locking/unlocking of door. In this system the fingerprint recognition is also adopted to enable the process of identifying of students more reliably and securely for facilities management.

RFID and fingerprint based attendance management system was developed to provide a faster, more secure, and more convenient method of user verification than passwords and tokens can provide for a reliable personal identification. As soon as student sweeps the card and fingerprint is scanned, the door gets opened and student is permitted to enter inside.

At the same time message on LCD gets displayed that the Student is present and at the same moment a message will be sent to the mobile that the Candidate 1 is present.

- After making all above connections, Switch on the Circuits.
- On LCD, Project name is displayed "RFID AND GSM BASED ATTENDANCE MONITORING SYSTEM AND ITS HARDWARE IMPLEMENTATION". Then again message will be displayed "PLS SCAN YOUR ID".
- A Student then sweeps the RFID tag near the RFID Reader.
- Reader then reads the data stored in the tag (Student ID) and transmits it to the microcontroller.
- Then the student has to scan the finger in the fingerprint sensor.
- Microcontroller compares the tag information and the fingerprint image with the database. Database means that program which is burned in AT89S52 I.C. If they are correctly matched then LCD displays" CORRECT ID" and takes your attendance.
- At the same moment, Door is opened and student permits to enter and at the same time

- SMS will be send to the parents mobile via GSM indicating that “Candidate 1 is present”. After some time the Door gets closed.
- Now place another card that is not present in our database for authentication.
- Now LCD displays “INCORRECT ID” and will never take the attendance. And the door will not

ADVANTAGES

- This System operates at a low cost.
- Automated operation.
- Low power consumption.
- Very Flexible and easy to manufacture.
- The main advantage that is provided by RFID gadget over above Stated attendance system is that is not necessary to place the card exactly near to the RFID Reader. Today, we know the problems faces by store billers that they have to scan the bar code of any item by exactly placed it to nearer to that scanner or the ATM debit card/credit card need to be swiped through card reader only. In comparison to this, RFID device can function from few feet away (approx... 20 feet for devices of high frequency) of the scanner machine.

APPLICATIONS

- It is very useful in educational institutions or an organizations, industries, home appliances, monitor and provide security of the office, industry etc.
- For the Security of petroleum products distribution such as petrol, diesel, and kerosene etc. If any product theft is there then a person comes to know by the use of our System
- This system allows booksellers to gain such information as the range of books a shopper has browsed, if any particular book is going low in number or any theft get is there then bookseller will get alert by SMS via GSM.
- In Bank Locker Security system.
- In Library management System
- Help visually impaired people in mobility
- Inventory and Asset Management
- Fleet management

get opened so the student is not permitted to enter inside.

- Again at the same moment SMS will be send to the parents mobile via GSM indicating that “Candidate 1 is absent”.
- In this way, we can implement this circuit.
- This system is used in various things like to unlock our car door, the automatic detection of payment while using tollbooths, payment cards and even passports.

RESULT

We developed our proposed system which is used to uniquely identify and record attendance for a person. An RFID and fingerprint automated attendance system was designed and implemented. Each student’s RFID card as well as fingerprint is captured and stored in the database. During attendance taking, the system prompts the student to place his/her finger on the fingerprint sensor, the print is then captured and compared to the one stored in the database if there is a match it then prompts the student to swipe his/her RFID card on the RFID reader, the card number is read and compared to the one in the database and if there is a match, the attendance of that student is marked and the door is opened and a confirmation message of attendance is sent to through the GSM. The whole process is viewed through the Liquid crystal display (LCD).

CONCLUSION

The developed RFID & GSM based Student Attendance System will be helpful in saving valuable time of Students and lecturers and helps to generate accurate reports at a required time. It also decreases the manual work to almost zero level.

The system provides an automatic approach in capturing the student attendance, i.e. students have to flash their RFID Cards (Student Ids) to the RFID reader. We are able to transmit messages via GSM SIM 300 Modem to the parents mobile so that parents get updated by the students attendance record and at the that same moment information

will be get displayed on LCD also indicating that the attendance has been marked.

However, some improvements can be made on this GSM System using RFID in order to increase its effectiveness and reliability. The developed system can be improved further by extending the system with Online Web based attendance system can be made by providing the Student Database to the Host Computer so that the Student's Record is to be updated automatically. This whole process of managing the Students Database is to be performed. Online with specific software installation.

Whenever Administrators are connected to Internet they can access the whole database from anywhere across the world. Risk of data loss can be reduced as compared to manual filing. Specific to lecturers or teachers, they can easily monitor their students' attendance online and this could improve the quality of teaching since less time is needed to manage the student attendance record. Better yet the system can be enhanced further to offer another significant enhancement where the system can be extended to monitor staff attendance record.

REFERENCES

- [1]. Available from: https://www.ijser.org/researchpaper/rfid-based_students-attendance_management-system.pdf, 2017.
- [2]. Available from: https://www.ajocict.net/uploads/V6N3P3-2013_Adetiba_et_al_-_OBCAMS_-_n_Online_Biometricsbased_Class_Attendance.pdf, 2017.
- [3]. Arulogun O. T., Olatunbosun A., Falolujo O. A., Olaniyi O. M. RFID-Based Students Attendance Management System. International Journal of Scientific & Engineering Research. 4(2), 2013, 1 – 9.
- [4]. Emmanuel Adetiba, Oghenetega Iortim, Anthony T. Olajide, Richard Awoseyin. An Online Biometrics-based Class Attendance Management System, African Journal of Computing & ICT 6(3), 2013, .25 - 38.
- [5]. Rufai M. M., Adigun J. O., Yekini N. A. (2012). A biometric model for examination screening and attendance monitoring in Yaba College of Technology, World of Computer Science and Information Technology Journal, 2(4), 2012, 120 – 124.
- [6]. Hanisah Binti Hamid, RFID based systematic student's attendance management system, 2010.
- [7]. Karthik V.E., Shanmuganathan S., A. Sumithra, S.Kishore, P.Karthikeyan, A Fool proof Biometric Attendance Management System. International Journal of Information and Computation Technology. 3(5), 2013, 433-438.