



---

## International Journal of Intellectual Advancements and Research in Engineering Computations

---

### Tracking System Using GPS/GSM/GPRS Technology with Accident detector

**ArunVarshan.S, Dhandapani.S, Subashini.S, Thangasurya.E, Mr.T.Jayachandran\***

UG Scholars, Department of ECE, Nandha Engineering College

\*Assistant Professor, Department of ECE, Nandha Engineering College

---

#### ABSTRACT

An efficient vehicle tracking system is designed and implemented for tracking the movement of any equipped vehicle from any location at any time. Speed is one of the basic reasons for vehicle accident. Many lives could have been saved if emergency service could get accident information and reach in time and also proposed to inform the accident. Sensor is used detect the drunken driver Nowadays; GPS has become an integral part of a vehicle system. This paper proposes to utilize the capability of a GPS receiver to monitor speed of a vehicle and detect accident basing on monitored speed and send accident location to an Alert Service Center. The GPS will monitor speed of a vehicle and compare with the previous speed in every second through a Microcontroller Unit. Whenever the speed will be below the specified speed, it will assume that an accident has occurred. The system will then send the accident location acquired from the GPS along with the time and the speed by utilizing the GSM network. This will help to reach the rescue service in time and save the valuable human life.

**Index Terms:** Traffic Safety, Naturalistic driving behavior, Accident Monitoring, GPS, GSM.

---

#### INTRODUCTION

The development of a transportation system has been the generative power for human beings to have the highest civilization above creatures in the earth. Automobile has a great importance in our daily life. We utilize it to go to our work place, keep in touch with our friends and family, and deliver our goods. But it can also bring disaster to us and even can kill us through accidents. In USA, 33,808 people died in vehicle traffic crashes in 2009. Speed is one of the most important and basic risk factors in driving. It not only affects the severity of a crash, but also increases risk of being involved in an accident.

Despite many efforts taken by different governmental and non-governmental organizations all around the world by various programs to aware against careless driving, yet accidents are taking majorplace every now and then. However, many

lives could have been saved if the emergency service could get the information in time. A study shows that 4.6% of the fatalities in accidents could have been prevented only in Finland if the emergency services could be provided at the place of accident at the proper time. As such, efficient automatic accident detection with an automatic notification to the emergency service with the accident location is a necessary one to save the precious life of the humans.

The Global Positioning System (GPS) is a popular technology. The GPS was developed by the American Department of Defense (DoD) for military use. Later it was available for civilian use. It is used for wide range of applications such as location, direction, speed, timing, surveying, logistics, traffic management, security etc. Nowadays, it has become an integral part of a vehicle system for tracking and navigation system.

---

**Author for correspondence:**

Department of ECE, Nandha Engineering College

It can provide accurate time, location coordinate and speed. On the other hand, Global System for Mobile communications (GSM) is a digital mobile telephony system that is used widely. More than 690 mobile networks provide GSM services across 213 countries and GSM represents 82.4% of all global mobile connections. Besides the voice communication it also provides Short Message Service (SMS) and General packet radio service (GPRS) to transfer data.

This paper is proposed to utilize the capability of a GPS receiver to monitor the speed of a vehicle and to detect an accident based on the monitored speed and send the location and time of the accident from the GPS data processed by a microcontroller by using the GSM network and to the Alert Service Center. The rest of the paper is organized as follows. The Related Work section discusses about the researches related to the accident detection system, the Equipments and Proposed Methodology section describes the required equipment's and algorithm to detect the accident, the Accident Detection and Reporting Procedure describes the procedure to calculate the speed to detect accident and sending procedure and finally the paper is concluded.

## RELATED WORK

Many researchers carried out their studies on accident detection system. Traditional traffic accident prediction uses long-term traffic data such as annual average daily traffic and hourly volume. In contrast to traditional traffic accident prediction, real-time traffic accident prediction relates accident occurrences to real-time traffic data obtained from various detectors such as induction loops, infrared detector, camera etc. Real-time traffic accident prediction focuses on the change of traffic conditions before an accident occurrence, while traffic incident detection studies are concerned with the change of traffic conditions after an incident occurrence. However, the performance of these detection and prediction system is greatly restricted by the number of monitoring sensor, available fund, algorithms used to confirm an accident, weather, traffic flow etc.

Besides the automatic detection system, manual incident detection methods detects the accident

from the motorist report, transportation department or public crews report, aerial surveillance or close circuit camera surveillance. The drawback of this type of detection system is that someone has to witness the incident. Moreover, there are delays and inaccuracies due to the expression problem of the witness. Compared to these detection method, driver initiated incident detection system has more advantages which includes the quick reaction, more incident information etc. However, with the severity of the accident, driver may not be able to report at all [1-5].

Conventional built-in automatic accident detection system utilizes impact sensor or the car airbag sensor to detect an accident and GPS to locate the accident place. L. Chuan-zhiet *al.* proposed a freeway incident detection system by utilizing the car air bag sensor and accelerometer, GPS to locate the accident place and GSM to send the accident location. However, the system did not utilize the GPS to detect the accident. A smart phone based accident detection system is proposed. However, smart phones are very expensive and due to false alarm filter, it may not detect all accidents. An acoustic accident detection method is proposed by D. A. Whitney and J. J. Pisano. There are possibilities of false alarm in the system and also does not guarantee the occurrence of an accident. Accident detection by utilizing an impact sensor and reporting system by wireless module is proposed. However, a wireless reporting infrastructure is very expensive and difficult to implement as installation of repeated receivers on the road at a very short interval are required. The proposed method aims to overcome the above mentioned limitations and utilizes only the GPS data to detect the accident and GSM network to send the location and activate a voice channel with the Alert Service Center [6-8].

## EQUIPMENTS AND PROPOSED METHODOLOGY

### GPS Receiver

The sensor for the accident detection is the GPS receiver. Nowadays, GPS technology has become more accurate, smaller, reliable, and economical. A very sensitive and accurate GPS

signal acquiring device is required for the system. The receiver continuously tracks all satellites in view and provides accurate satellite positioning data. Its 20 parallel channels and 4000 search bins provide fast satellite signal acquisition and short startup time which is <8 second in hot start and

<40 second in cold start. Tracking sensitivity of -159dBm offers good navigation performance even in urban canyons having limited sky view. It provides output in NMEA standards in every second which allows monitor the speed continuously.



**TTL GPS Receiver**

### **GSM/GPRS Modem**

The GSM/GPRS modem utilizes the GSM network to send the location of the accident. The modem can be controlled by a microcontroller through AT Command set. GSM/GPRS engine-SIM900A works on frequencies 900/ 1800 MHz. The Modem is coming with RS232 interface,

which allows you connect PC as well as a microcontroller with RS232 Chip (MAX232). It is suitable for SMS, Voice as well as DATA transfer application in M2M interface.. It supports dual frequency (GSM/GPRS 900/1800MHz) with voice function and RS-232 interface. This modem supports all the AT Commands.

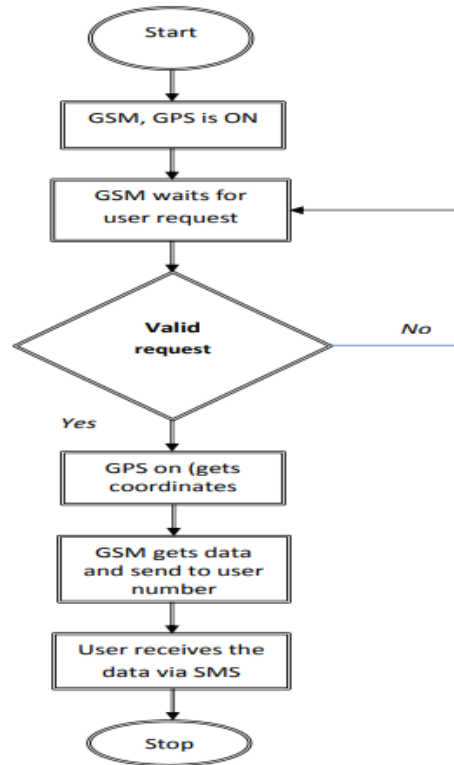

**SIM900A GSM Modem**

### Microcontroller Unit

The microcontroller unit (MCU) is the heart of the system. It receives data from the GPS, processes all data and detects the accident from the processed data. The location of the accident is also

sent by the microcontroller (PIC16F877A) is proposed for this system. The Large amounts of RAM is used for buffering, Enhanced Flash program memory and low power consumption make it ideal for the proposed system.

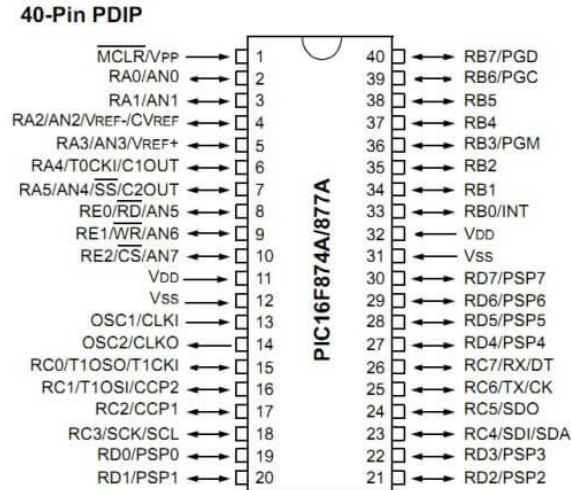

### Accident Detection Algorithm

Speed is one of the most important and basic risk factors in driving. It not only affects the severity of a crash, but also increases risk of being involved in a crash. People need some processing time to decide whether or not to react and then to execute an action. At high speeds the distance between starting to brake and a complete stand still is longer. The braking distance is proportional to the square of speed. Therefore, the possibility to avoid a collision becomes smaller as speed increases. A moving body contains kinetic energy. When an accident occurs, kinetic energy is transformed into destructive forces cause injury to occupants as well as to the vehicle.

$$\text{KineticEnergy} = \frac{1}{2}mv^2 \quad (1)$$

Where  $m$  = mass of object and  $v$  = speed of the vehicle.

When brake is applied, two forces work on the vehicle to decelerate the speed. One is the gravitational force ( $g$ ) and the other one is the friction force ( $f$ ). Considering the friction coefficient 0.8 for a plain road surface and standard gravitational force (9.8 metres per square second), we can get the final speed of a vehicle ( $u$ ) after one second once the brake is applied. This is the maximum speed after considering the deceleration factors. Table 1 shows the maximum speed starting from the initial speed of 160 kph after one second once the brake is applied. As such, if the speed is less than these maximum speed, than it would be assumed that some other deceleration force worked on the vehicle to reduce the speed and an accident has occurred.

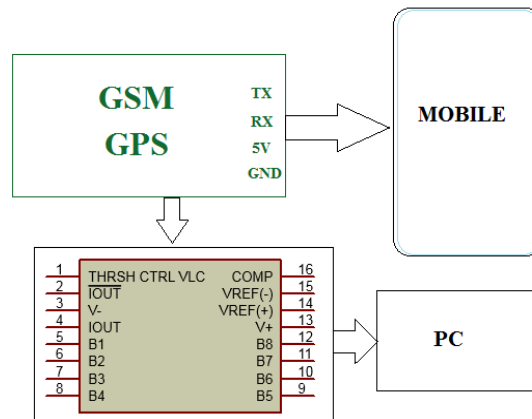

## ACCIDENT DETECTION AND REPORTING PROCEDURE

### Speed Measurement

Many techniques can be used to measure vehicle speed. The most common is the car speedometer. But analog to digital converter is required to acquire speed from the speedometer. Laser speed guns are limited to single point and instantaneous measurements. But a GPS receiver provides speed information in every second. Therefore, it is more convenient to monitor the speed with a GPS receiver.

GPS receiver communication is defined by National Marine Electronics Association (NMEA) specification. The idea is to send a line of data called a sentence that is totally self-contained and independent from other sentences. Out of these sentences, GPRMC is the most common sentence transmitted by the most GPS devices. This sentence contains nearly everything a GPS application needs.

### Detection Procedure

GPS provides data in RS-232 protocol. As such, a level converter (MAX232) is required to convert it to TTL and to connect it with the MCU's transmit and receive in. The GPS receiver acquires the sentence in every second. From the GPRMC sentence, the speed information will be extracted

by counting the number of comma, by the MCU. Two memory spaces will be allocated for the speed, one memory space for the time and another for the latitude and longitude. The latest time and latitude/longitude will be always saved in the memory overwriting the previous values. The last two speed information will be always kept in memory. The latest speed information will be stored in the first memory space and will move to the second memory speed once new speed information is acquired. The MCU will compare the latest speed with the previous speed. If the speed is less than the maximum speed found from, the MCU will raise a flag to indicate that an accident took place.

### Reporting Procedure by MCU

When a flag is raised for accident, the MCU will initiate an emergency situation automatically. The MCU will wait for 5 seconds for the driver to press a button to cancel the accident reporting procedure. This will enable to reduce the false alarm to the Alert Service Center. Once the 5 seconds waiting time is over, the accident information containing the location, time and the speed along with the contact number of relative of the occupant will be sent as a GPRS data to the Alert Service Center through the GPRS modem by the MCU.

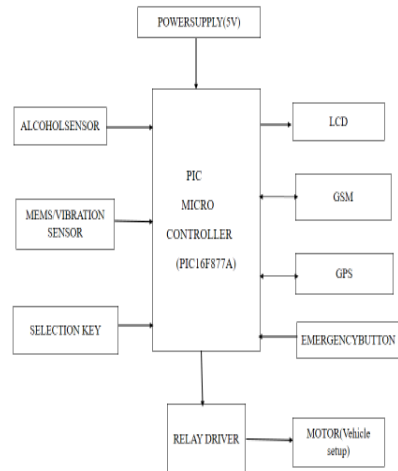

GPRS coverage is not always available in every place. As such, simultaneously an SMS will also be initiated containing the same information. After the SMS is sent, the MCU will also initiate a voice call to the Alert Service Center. This will enable the vehicle occupant to describe the emergency situation if they are in a condition to describe. Besides automatic accident detection system, by pressing the Manual Detection Switch, the vehicle occupant will also be able to initiate an emergency situation and it will report like the automatic accident detection system.

### Accident Data Interpretation

The information sent as a GPRS data and SMS will be received by a GSM/GPRS modem

connected to a computer. A middleware will be written to interpret the SMS and GPRS data. An appropriate program will be written so that Google Maps can be incorporated and the accident location is automatically plotted in the map utilizing the information from the interpreted SMS/GPRS data. It will also show the previous speed of the vehicle before committing the accident. This data will help the Alert Service Center to assess the severity of the accident basing on the speed. The modem will also establish a voice channel with the Alert Service Center.

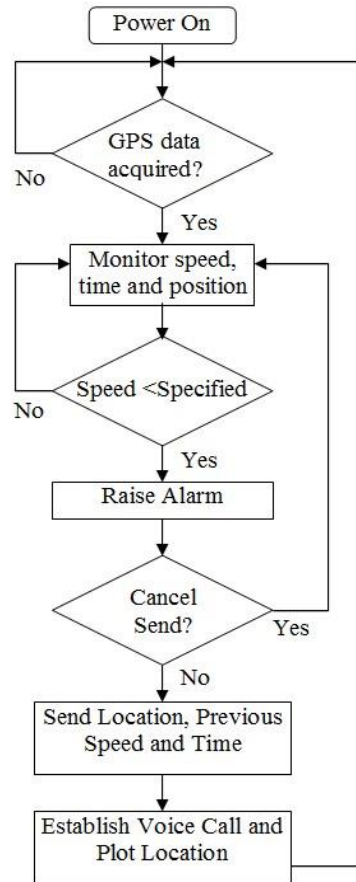

**Flowchart of the accident detection and reporting system**

## CONCLUSION

Speed and drunken drive are the major causes for an accident. Nowadays, GPS receiver has become an integral part of a vehicle. Besides using in other purposes, the GPS can also monitor the speed and detect the location of an accident. It can use a very cheap and popular GSM modem to send the accident location to the Alert Service Center. It can also send the last speed before accident which

will helps to assess the severity of the accident and can initiate a voice call. Beside the automatic detection system, the vehicle occupant will be able to manually send the accident situation by pressing the Manual Detection Switch. A rescue measures in time with sufficient preparation at the correct place can save many life. Thus, the proposed system can serve the humanity by a great deal as human life is valuable.

## REFERENCES

- [1]. R.K. Mega lingam, R.N. Nair and S.M. Prakhya, "Wireless Vehicular Accident Detection and Reporting System," in International Conference on Mechanical and Electrical Technology (ICMET 2010), 2010, 636-640.
- [2]. G.Marfia, et al., "Safe driving in LA: Report from the Greatest Intervehicular Accident Detction test ever", IEEE Trans. On Vehicular Technology, 62(2), 2013, 522-535.
- [3]. Alan M John, BhaveshPurbia, Ankit Sharma, Mrs. A.S Udupurkar, "LPG/CNG Gas leakage Detection System with GSM Module", International Journal of Advanced research in computer and Communication Engineering-6(5), 2017.

- [4]. T. Mantoro, M.A. Ayu, A. Borovac, "GPS Based Tracking Framework for Walking Pedestrian", Informatics Engineering and Information Science Communication in Computer and Information Science, 252(3), 2011, 337-348.
- [5]. B.Venkateswara Reddy, D.V. Subba Rao," Vehicle Tracking and Accident Identification System", International Journal of Applied Sciences, Engineering and Management ISSN 2320-3439,4(1), 2015, 06-12.
- [6]. Q.Liu, B. Lathrop, and V. Butakov, "Vehicle Lateral position prediction: A small step towards a comprehensive risk assessment system," in Proc. 17<sup>th</sup>Int.IEEEConf.Intell. Transp.Syst.(ITSC), 2014, 667-672.
- [7]. T.Jayachandran and D.Arulalanatham," Design of Low voltage Comparator for Analog to Digital Conversion", International Journal of Advanced Research in Electrical, Electronics and Instrumentation Engineering, 3(12), 2014, 13697-13703.
- [8]. T.Jayachandran "DESIGN OF DOUBLE TAIL COMPARATOR FOR ANALOG TO DIGITAL CONVERSION", Unique Journal of Engineering and Advanced Sciences, ISSN 2348-375X 2, 2014, 63-66.