



---

## International Journal of Intellectual Advancements and Research in Engineering Computations

---

### Wireless electricity theft detection using ZIGBEE

**Dr.P.Sukumar<sup>1</sup>, S.Mounika<sup>2</sup>, G.Nesan<sup>2</sup>, B.Boopathi<sup>2</sup>, M.Vinoth Kumar<sup>2</sup>**

<sup>1</sup>Professor, Department of ECE, Nandha Engineering College(Autonomous),Erode-52,Tamil Nadu

<sup>2</sup>UG Students Department of ECE, Nandha Engineering College(Autonomous),Erode-52,Tamil Nadu

---

#### ABSTRACT

Electricity is building block of any nation so it is necessary to monitor and control the uses of theft of electricity. Wireless electricity theft detection system using Zigbee module present an efficient and less costly way to adulterate the wireless technique.The regional/individual theft detection algorithm and the abnormal consumption pattern signal are designed for shortlist regions with a high probability of theft and selecting suspected fraudulent customers in real time.In early days theft detection is used to find out using gsm but that system having a drawback such as tampering area is not find out and transmission loss is not calculated.To overcome this problems we used to implement our proposed method ,Mainly this system consists of microcontroller, and a Zigbee module to check for the theft of electricity and then make an alarm to the actual user.AVR studio andWIN AVR compilers are the softwares used for this system for detecting theft.

**Keywords:** Atmega8 Microcontroller, Zigbee Transmitter And Receiver, Current Transformer, AVR Studio, Relay, Liquid Crystal Display.

---

#### INTRODUCTION

India is the largest democracy with an estimated population of about 1.04 billionpeople , is on a road to rapid growth in economy. Energy, particularly electricity, is a key input for accelerating economic growth of our country. The theft of electricity is a major criminal offence and power utilities are losing billions of rupees year by year. The following sections will describe the proposed detection and control system forthe illegal electricity usage using the power lines using zigbee.The theft of the electricity is the major problem over worldwide. The transmission losses in the supply of the electricity are increasing day by day. The electricity is being stolen by bypassing the energy meters therefore this wireless system is utilizes to overcome this type of the electricity theft and is very beneficial for the authorized persons to control its revenue. Power theft is the biggest and major problem in recent times which

leads to huge loss to the electricity boards.. So if we can prevent this theft related to electricity then we can save lot of power which will in turn be very beneficial for our future uses.

Rampant power theft at the low voltage consumer end is a growing concern for the power distribution companies. This paper proposes an effective method for detection of power theft at low voltage consumer end. The proposed method is designed to reliably detect hooking in service line cable and bypassing of electric energy metr. In this method, a low magnitude, high-frequency, non-interfering signal has been injected into the power line. Two LC traps have been designed and placed on either side of the energy meter to restrict the flow of the injected component from reaching the load end. In either case of bypassing or hooking, the power of the high-frequency component will deviate from its value under normal operating condition.

---

#### Author for correspondence:

Department of ECE, Nandha Engineering College(Autonomous),Erode-52,Tamil Nadu

Here this system utilizes the technique named ZIGBEE because all the problems associated with the wired techniques early days. There are a lot of problems related with the wired techniques such as installation problem, and high cost. The problem associated is about the rural areas where it's really difficult to install the wired system to convey the information. The ZIGBEE module provides a good and efficient way to convey this information to the authorized person at low cost as compare to that of the GSM Modem or any wired technique.

## ZIGBEE TECHNOLOGY OVERVIEW

An IEEE 802.15.4 standard ZIGBEE is used for data communications with business and the consumer devices. ZIGBEE is designed around low-power consumption allowing the batteries to essentially last forever. Operating on Top of the IEEE 802.15.4 Medium Access Control (MAC) and Physical Layer (PHY) wireless standard the ZIGBEE standard provides network security. Employing a suite of technologies it enables scalable, self-organizing, that can manage various data traffic patterns. ZIGBEE is a low-cost, low-power, mesh networking standard. The lower cost allows the technology to be widely deployed in wireless control application.

The mesh network provides high reliability and larger range of operations. ZIGBEE has been developed to meet the growing demand for capable wireless networking between various low power consumption devices. The ZIGBEE will also serve as the official test and certification group for ZIGBEE devices. ZIGBEE is the only standards-based technology that addresses the needs of most remote sensing and monitoring and control and sensory networks applications. The 802.15.4 specification only covers all the lower networking layers. It uses unlicensed 2.4 GHz ISM band it is available worldwide. ZIGBEE has range between

15 m to 3 km and it works well with networks such as Wi-Fi, Ethernet makes it suitable to be used in controlling and monitoring application.

## LITERATURE SURVEY

The main problem identified is large amount of power shortage is caused due to power theft. Power theft is considered as a crime. Illegal connection can severely overburden the grids and invite power wastages responsible electricity user may suffer power problems. Manually it is difficult to detect the theft of electricity. Power theft in transmission lines is shown in fig 1.

[1] Implement a theft detection method in 2015, but this system uses power line communication method having drawback as tampering area is not detected. And the other author [2] proposed a method of power theft automatic energy meter reading having drawback such as If theft occur supply cut off from EB Side and Record of billing within certain period message from EB side. The other method proposed by [3] of detecting survey of power theft technique using method SVM, ELM, ANN having disadvantage such as Detection rate accuracy (%) is differ from one algorithm.

The other method implemented in the year 2016 by [4] Survey on identify electricity theft using data mining technique using method such as ANN-K-Means cluster in algorithm. Fuzzy logic which having cons such as implementation is very difficult. In the year 2016 [5-8] Mali implemented a method of Survey: Electricity Theft Detection Technique having drawback as Less Accuracy and Installation problem. In the year 2017; [9,10] implement a power theft detection using gsm having problem such as Automated smart metering Power consumption is monitored by mobile only it is not good at all times working.



**Fig[1]:Power theft in transmission lines**

In the year 2017; Muhammad [11] proposed a method Theft detection based GSM Prepaid electrical system having drawback such as complex design an installation problem. Later in the year 2017 [12 ]implement a method Development of cost effective electricity theft detection & prevention system based on IoT Technology but having serious drawback such as Detects human tampering ,If robot is programmed to tamper the meter this system is useless ,Passive IR sensor detects human within 5m. Again in the year 2017 [12] implement a method IoT Based power theft detectionhaving drawback such as ESP Module is used but It sometimes cause too much reliability problems Wifi codes takes lot of CPU power.

In 2017 [13,14] Implement a method of power theft detection using RF Technology having problem such as Onetime installation cost and used for lifelong Circuit implementation is simple. In 2018; [15] GSM based electricity theft using arduino had some demerit such as No human interface Cost high to implement. Received theft tampering messages to mobile. To overcome these problems in the electricity theft detection. we used to implement our proposed method by find out the tampering area and transmission loss and good installation facility our proposed method will help to overcome these types of problems in future .survey of power theft all over India is shown in fig 2.

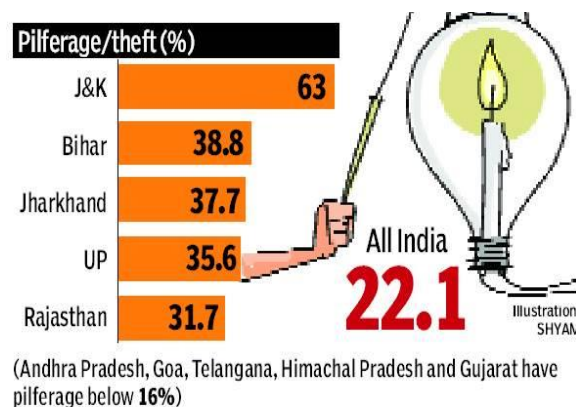

**Fig[2]:survey of electricity theft all over India**

Rampant power theft at the low voltage consumer end is a growing concern for the power distribution companies. This paper proposes an effective method for detection of power theft at low voltage consumer end. The proposed method

is designed to reliably detect hooking in service line cable and bypassing of electric energy meter. In this method, a low magnitude, high-frequency, non-interfering signal has been injected into the power line.

## SOFTWARE DESCRIPTION

AVR studio is an Integrated and Development Environment (IDE) by ATMEL for developing applications based on 8-bit AVR microcontrollers. Prior to installation of the AVR Studio you have to install the compiler Win AVR. wever, it is commonly accepted that the AVR stands for Alf and Vegard's RISC and CISC processor. AVR is a family of microcontrollers developed since 1996 by the Atmel corporation, acquire by Microchip Technology in the year 2016.AVR was one of the first microcontroller families to use on-chip flash memory for program storages, memory as opposed to the one-time programmable ROM and RAM, EPROM, or EEPROM used by other microcontrollers at the time.AVR Library is a free Software Atmel AVR microcontrollers.

Together, avrbinutils, avr-gcc, and avr-libc form the heart of the Free Software tool device tool chain for the Atmel AVR microcontrollers.

Download the latest Atmel Studio installer, AVR Studio, Atmel Studio. The web installer is a

small file (<10 MB) and which will download specified components devices as needed. The offline installer has every required components embedded Atmel Studio can be run side-by-side with older versions of Atmel Studio and AVR Studio. Un installation of any previous versions is not required. Verify the hardware and software requirements from the 'System Requirements' section make sure your user has local administrator privilege. Save all your work before starting. The installation might prompt you to restart if required. Disconnect all the USB Serial hardware devices, Double-click the installer executable files and follow the installation wizard Once finished, the installer displays an option to Start Atmel Studio after completion. If you choose to open, then note that Atmel Studio will launches with administrative privileges, and since the installer was either launched as administrator or with elevated privileges, In the Atmel Studio you may see an update notification next to the Quick Launch the fields in the title bars.

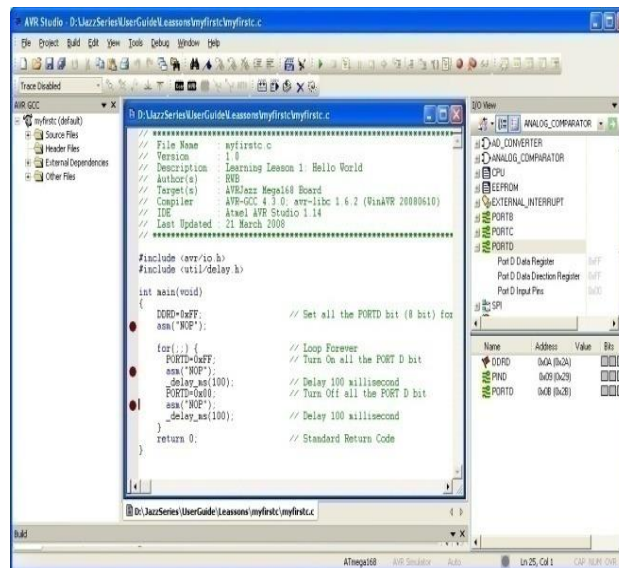

Fig[3]: AVR Project window file

## PROPOSED METHOD

### TRANSMITTER SIDE

#### ATmega8 Microcontroller

AVR Microcontroller was produced by the "Atmel". The Microcontroller includes the Harvard

architectures that works rapidly with the RISC processor. The features of this Microcontroller include different features like sleep modes, internal oscillator and serial data communication, performs the instructions in a single execution cycle faster and easier mode. These

Microcontrollers were very fast and they utilize low power to work in different power saving modes and operations. There are different configurations of

AVR microcontrollers are available to perform various operations like 8-bit, 16-bit, and 32-bit and 64 bit.

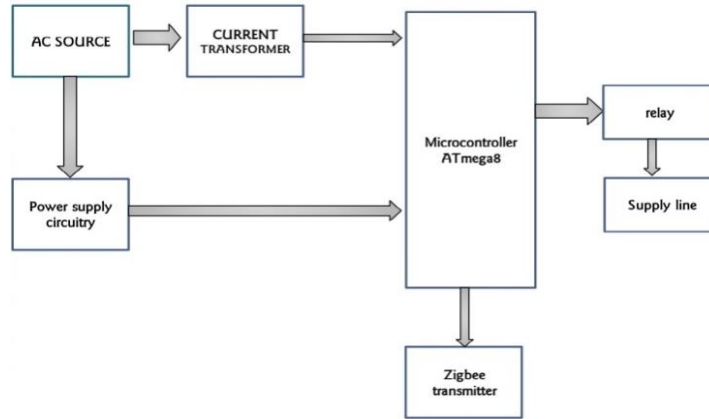

**Receiver side**

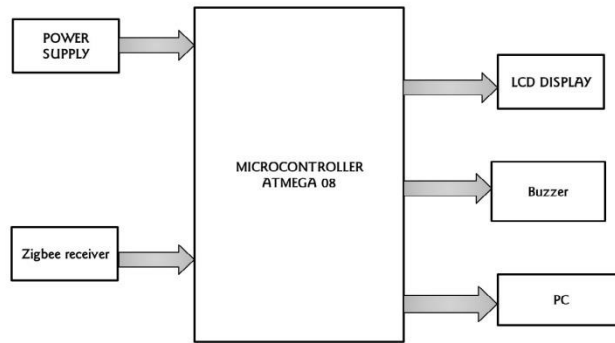

**Current Transformer**

The Current Transformer is a type of “instrumental transformer” which is designed to produce an alternating current AC in its secondary windings which is proportional to the current being

measured in its primary coil. Current transformers are used extensively for measuring current and power voltage and monitoring the operation of the power grid. Current transformer is shown in fig 4 below.

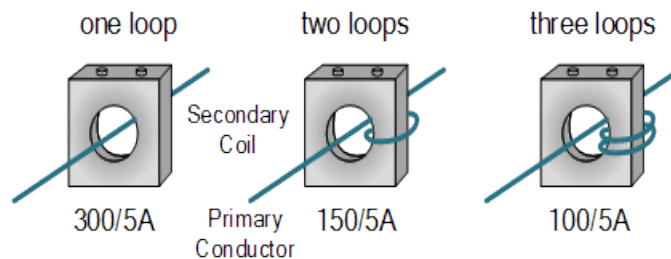

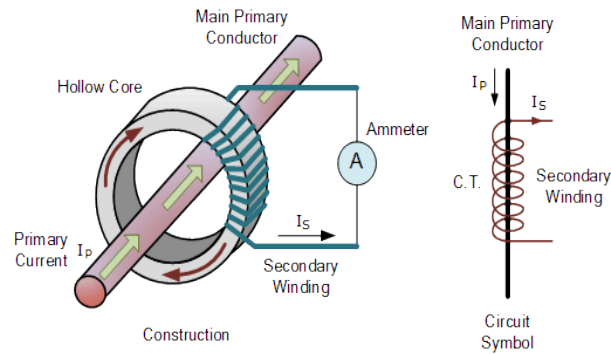

**Fig [4] current transformer**

## Relay

Relays are switches type that open and close circuits electromechanically or electronically. Relays control one electrical circuit by opening and closing the contacts in another circuit. Relays are used in switching circuits by giving a small signal to the coil inside it, When a signal is sent into the coil.

## Zigbee

ZigBee is an IEEE 802.15.4- standard specification suited for high-level communication protocols used to create personal area networks with small, low-power digital radios, networks such as for home automation, medical devices data collections, and other low-power consumption and low-bandwidth needs, designed for small scale projects which is shown in fig 2.

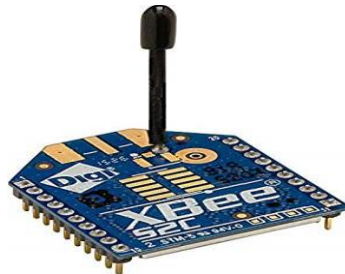

**Fig [5]zigbee module**

## Power supply

A power supply is an electrical device that supplies electric power to the electrical loads. The main functions of the power supply is to convert electric current from the source, to the correct voltage, as electrical power converters. Some power supplies are separated by stand alone pieces of equipment, while others are built into the load appliances that they power.

electrical. A 16x2 LCD means it can display 16 characters per line and there are 2 such lines and displays messages.

## Buzzer

A buzzer or beepers are an audio signalling devices in electrical items, which may be electrical, mechanical, electromechanical, or piezoelectric. Typical uses of buzzers and beepers include alarm devices, timer indicators detectors.

## LCD

LCD (Liquid Crystal Display) screen is an electronic display module and to find a wide range of applications. A 16x2 Liquid crystal display is very basic modules and is very commonly used in various devices and circuits in electronics and

## PC

A personal computer is a multi-purpose computer whose size, shape, intelligence, capabilities, and price make it feasible for individual use. Personal computers are intended to

be operate directly by an end user, rather than by a computer expert or technician

## METHODOLOGY

### Transmitter side

The proposed system deals with the idea of developing a system that prevents electricity theft. Here a microcontroller atmega8 is fixed in both transmitter side and receiver side. In both transmitter and receiver side the zigbee transmitter and receiver is fixed with the atmega8 microcontroller at input and output ports. A microcontroller is used which acts as the central control unit of the sysetm which coordinates and controls all the input and output devices. Transmitter part consisting of two current transformer which iks connected in the load.

Then transformer is used to fix in the transmitter side to step down the ac current source and rectified to 12V dc current source ,because all the zigbee and other devices in our project works in the dc current source. The current transformer here acts as the power sensor. The microcontroller ATmega8 continuously monitors the signal from the current transformer. Incase of any extra load on the load side, there will be a varying signal from current transformer, and the controller is programmed in such a way that when the signal from the current transformer goes beyond the threshold value, the relay has to be shut down. When there is any tapering or fraud connections occurred in our transmission lines or energy meters or transformers the load resistance may change automatically.



**Fig[6]:Initial condition of LCD Display**

### Receiver side

In the receiver section the atmega8 microcontroller is fixed which is connected with the zigbee receiver and the power supply. The power supply block is the one that supplies power to the microcontroller ATmega8 ,zigbee receiver and the liquid crystal display. The microcontroller ATmega8 does the job of displaying the data that is received from the zigbee receiver. If there is any tampering occurred in the transmitter side, the zigbee transmitter transmits the data to the zigbee

receiver side, then the sensor senses the output and displayed on the liquid crystal display and buzzer and the pc which is already programmed and dumped on the microcontroller. The parameters are viewed on the LCD ,PC and Buzzer. In the display if there is any load connected by us initially the meter is no theft condition, if there is any tampering occurred in our load side the transmission loss is indicated on the LCD and it displays electricity theft at which area or place in the line in the display.



**Fig[7]: LCD Displaying for bypassing**

## CONCLUSION

The new proposed system introduces a new technique of detection of theft of electricity. The results under the no theft condition and theft condition has proved that the embedded system technique can be effectively used for the detection of the theft of electricity in the Power system. By using this technique electricity power theft in our home, industries, factories are easily find out and calculated without any human interface. The crime of stealing power may be brought to an end and thereby a new bloom may be expected in the

economy of our motherland and also there will no wastage of electricity and power in our nation.

## FUTURE SCOPE

- Automatic meter reading and billing in water management system.
- Notification via SMS or email of billing of any information related to the power management systems.
- Online billing systems should be link with this systems.

## REFERENCES

- [1]. Rakesh dwivodi, Ashwanikumar, Sandhya dubey "Design and implementation of power theft detection in automatic meter reading using power line communication" IJEETC ; 1(2), 2015.
- [2]. G.Kate ,R.Rana " Zigbee monitoring theft detection using automatic electricity meter reading" ICESA ;2015.
- [3]. M.Jain ,A.M.KarandiakrA survey of power theft detection" IJIRCCE, 4(1), 2016.
- [4]. C.Dhendwaldiksha ,H.Yadevmayer, Prof.BalaKumkum "Survey on identify electricity theft using data mining technique" IJIRCCE; 4(11), 2016.
- [5]. PratapJumale, Avinash, Khaire, Harshada, Jadhawar, Sneha ,Awathare, Manisha Mali "Survey Electricity Theft Detection Technique" International Journal of Computer Engineering and Information Technology, 8(2), 2016.
- [6]. M.K.Sangole, AkshayBhandane, Nitin bhandane, Giridhari balder "Smart Energy Metering and Power Theft Control using Arduino &gsm" 2nd International Conference for Convergence in Technology I2CT, 2017.
- [7]. Visalatchi ,kamalsandeep, "Smart Energy Metering and Power Theft Control using Arduino &gsm" 2nd International Conference for Convergence in Technology I2CT, 2017.
- [8]. Muhammad saad ,Muhammadfaraztariq " Theft detection based GSM Prepaid electrical system", IEEE-9781-53-86-0484, 2017.
- [9]. R.E.Ogu, G.A.Chukwvdebe "Development of cost effective electricity theft detection & prevention system based on IoT Technology" IEEE-3<sup>rd</sup> ICETND 2017.
- [10]. R.Giridharbalakrishna, P.Yoganandhareddy M.L.N.VitalIoT Based power theft detection", IJiet, 8(3), 2017.
- [11]. Saurabh Singh, KrishnaYadav, HarjeetMatharu, Prachi Singh, Anvita Birje "Electricity and power theft detection" International Journal of Innovative Research in Science, Engineering and Technology 6(11), 2017.

- [12]. L.Hinduja ,B.Priyavardhana“GSM based electricity theft using arduino ” IJEECS 7(3), 2018.
- [13]. V.A.VelgnanaVenkateshDr.P.Sukumar ,K.Mothiram , N.Narmatha , B.Pavithra2018International Journal of Intellectual Advancements and Research in Engineering Computations 6(1), P209-21.
- [14]. P Sukumar, S Ravi, K Tamilselvan 2016 International Journal of Emerging Technologies in Engineering Research (IJETER) “Secured Wearable Bio-Sensor System Using ZigBee for Monitoring Sick Patients”.
- [15].”Design and Implementation of a Microcontroller Based Buck Boost Converter as a Smooth Starter for Permanent Magnet Motor “S Ravi, VitaliyMezhuyev, K IyswaryaAnnapoorani, P Sukumar Indonesian Journal of Electrical Engineering and Computer Science 566-574.