



## International Journal of Intellectual Advancements and Research in Engineering Computations

### Solar based trapper for pest control

**Nandhakumar.P<sup>1</sup>, Priyatharsan.P<sup>1</sup>, Ramkumar.S<sup>1</sup>, Sivakumar.P<sup>1</sup>, Mr.T.Jayakumar<sup>2</sup>**

<sup>1</sup>Under Graduate, Dept of EEE, Nandha Engineering College, Erode, Tamilnadu ,India

<sup>2</sup>Assitant Professor, Dept of EEE, Nandha Engineering College, Erode ,Tamilnadu, India

#### ABSTRACT

Farmers encounter the problems of various types of insect pests that harm crops and result in loss of productivity each year. Therefore, it is necessary for farmers to use pesticides to prevent crop damage. However, when pesticides are used in large quantity, they cause adverse impacts on people, animals and the environment. This study aimed to develop Solar Energy-Based Insect Pests Trap by using ultraviolet light emitting diode tube to lure the insect pests and 12 volt battery as power supply to light emitting diode tube.

#### INTRODUCTION

##### **Agriculture is a principal occupation in Thailand.**

Every year farmers face pest problems which seriously destroy crops. There are many preventions and exterminations of pest problems, such as mechanical method, physical method, biological method, and chemical method. Using pesticides and chemical method directly affects on agriculturists and consumers, for example, pests are chemical resistant which leads farmers using more and more pesticides.

This causes plant residue which is dangerous for consumers, and also effects on environment and ecology. At present, the consumers emphasize on safe and non-chemical food. The producers should be aware of this matter and reduce pesticide to decrease farmers' and consumer's health problems by creating non-chemical and pesticide measures. Moreover, agriculturalists has tried to find other ways instead of chemical used such as using lights to tempt pests which is popular way for farmers. However, that way is still lack of electric energy for bulbs because the farm is far away, and trap is also expensive. From this point, the researcher has developed Solar Energy Based Insect Pest Trap for orchards and vegetable [1.3].

#### EXISTING SYSTEM

We manufacture and supply Solar Powered Insect Trap which is an effective solution for insect control in crop fields. This cutting edge device identifies the Pest and Insects pattern and develops Pest Management and control plan accordingly. Our Solar Powered Insect Trap is very easy to install and operate. Solar Powered Insect Trap offered by us is completely automatic, economical and eco-friendly device.

#### PROPOSED SYSTEM

The main structure of Solar Energy-Based Insect Pest Trap is made from steel for durable using in agricultural fields. Its height is 150 centimeters. On the top of Insect Pest Trap, install the 20 watts solar cells panel, size 45x45 cm, 10-15 degrees of elevation angle for solar effective. The base of the trap is steel plates to mount the ground. The insects tempt consists of 30x40x15 (width x length x thickness) clear acrylic square box which can let LED light out of the box. There is wire mesh of electronic mosquito trap on one side of the box. There are 150 LED size 7x7 mm; 5 rows of 30 LED bulbs each inside the box. Other stuffs are 5 amps battery charger, 12 V 14 Ah Sealed Lead Acid Calcium battery, light sensor switch circuit, and high voltage circuit of mosquito

#### Author for correspondence:

Department of EEE, Nandha Engineering College, Erode, Tamilnadu, India

trap are set in steel box to prevent from any damages .

Nowadays there are many ways to destroy insect and reduce damages from pest. Besides,

there are pests in exported products that affect on export value and setting price of agricultural products. Insect and pest control is necessary for agriculturists to solve the problem.

## BLOCK DIAGRAM

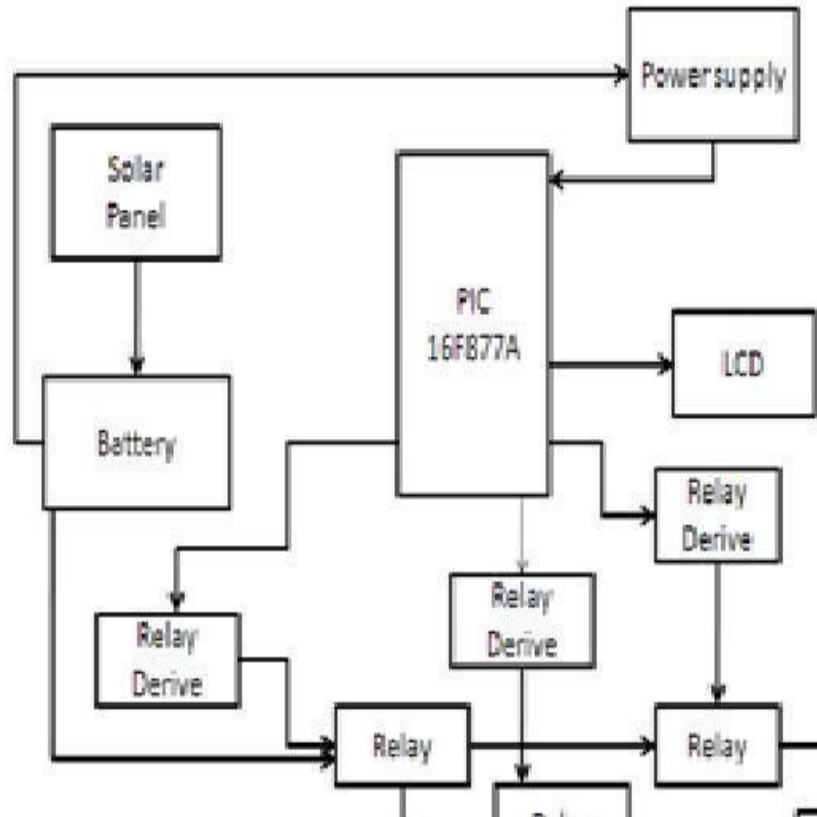

Fig 1. Block diagram of proposed system

## PIC16F877A

PIC16F877a is a 40-pin PIC Microcontroller and is used mostly in Embedded Projects and Applications. Few of its features are as follows: It has five Ports on it starting from Port A to Port E. It has three Timers in it, two of which are 8 bit Timers while 1 is 16 Bit. It supports many communication protocols like:

- Serial Protocol.
- Parallel Protocol.
- I2C Protocol.

It supports both hardware pin interrupts and timer interrupts. Here's the PIC16F877a Pin Diagram, I have mentioned the names of all the Pins and have also given different colors to different Ports. The above image gives you the overall idea of PIC16F877a Pins and Ports. You should also have a look at Introduction to Atmega 328, it's another microcontroller, you should compare them [4].



**Fig 2. Pin diagram of PIC16F877A**

## METHODOLOGY

The Solar Energy-Based Insect Pest Trap research is an experimental research. The purpose is, to produce and invent Solar Energy-Based Insect Pest Trap by using ultraviolet LED bulbs as light source. The ultraviolet is effective wavelength to tempt insects. Solar cells are used to change solar energy to electric energy and change to battery for pest trap. After that, bring the trap to test the effectiveness and results of pest trap in agricultural areas.

## CONCLUSION

This solar energy-based insect pest trap research chose general materials to be adapted for pest trapping such as electronic mosquito trap and

clear acrylic board. Then simple design was created for easily teach to farmers. 2. The Solar Energy-Based Insect Pest Trap can trap many pests such as Coccinellidae, Nephrotettix nigropictus, Adult cotton leaf worm, Leaf minor fly, Rhinoceros beetle, and Brontispa longissima Gestro. They are general pests in farm around Thailand but small number can be destroyed because there was only one side of wire mesh

## RESULT

The result of insect and pest trapping found that, Coccinellidae, Cicada leafhopper, Adult cotton leaf worm, Leaf minor fly were trapped in orchard. The Rhinoceros beetle and Brontispa longissima Gestro were trapped coconut farm.

## REFERENCE

- [1]. N. Aflitto and T. DeGomez, "Sonic Pest Repellents", The University of Arizona Cooperative Extension, 2005, 1-4.
- [2]. S. Jhaveri, R. Singh and T. Hiremani, "Electronic Pest Repellent", [www.ee.iitb.ac.in](http://www.ee.iitb.ac.in), 2009. [Online]. Available: [www.ee.iitb.ac.in/uma/~we1/we145/public\\_html/ed109s/b01.pdf](http://www.ee.iitb.ac.in/uma/~we1/we145/public_html/ed109s/b01.pdf)
- [3]. "LM317 3-Terminal Adjustable Regulator", [www.ti.com](http://www.ti.com), 2016.
- [4]. Nur Najiah Binti Mohd Nasir, "Design A Smart Insect Repeller Using Ultrasonic Sensor", Faculty Of Electrical & Electronics Engineering, Universiti Malaysia Pahang, 2012.
- [5]. "LM340, LM340A and LM7805 Family Wide VIN 1.5-A Fixed Voltage Regulators", [www.ti.com](http://www.ti.com), 2016. [Online]. Available: <http://www.ti.com/lit/ds/symlink/lm7805.pdf>.