



International Journal of Intellectual Advancements and Research in Engineering Computations

IOT based underground cable fault detector

M.Boopathi¹, R.Karthikeyan¹, R.Gowthaman¹, S.Krishnakumar¹, M.Prabu²

¹Students, Nandha Engineering College (Autonomous)

²Professor, Nandha Engineering College (Autonomous)

ABSTRACT

Underground cables are prone to a wide variety of faults due to underground conditions, wear and tear, rodents etc. Diagnosing the fault source is difficult and entire cable should be taken out from the ground to check and fix faults. The project work is intended to detect the location of fault in underground cable lines from the base station in km using a PIC16F877A controller. The objective of this project is to determine the distance of cable fault from the base station in unit distance using PIC board.

Keywords: Underground Cable, Fault Location, Location Methods, Microcontroller, Webpage.

INTRODUCTION

Power supply networks are growing continuously and their reliability getting more important than ever. The complexity of the whole network comprises numerous components that can fail and interrupt the power supply for end user. For most of the worldwide operated low voltage and medium voltage distribution lines, underground cables have been used for many decades. Underground high voltage cables are used more and more because they are not influenced by weather conditions, heavy rain, storm, snow and pollution.

Even though the Cable manufacturing technology is improving steadily, there are still influences which may cause cable to fail during test and operation.

Cables can be easily damaged by incorrect installation or poorly executed jointing, while subsequent third party damage by civil works such as trenching or curb edging.

OBJECTIVE

The objective of this project is to determine the distance of cable fault from the base station in unit distance using PIC board.

TYPES OF CABLE FAULT

Open circuit fault

A break in the conductor of the cable, it is called open circuit fault of the cable. The open circuit fault can be checked by megger. For this purpose, the three conductors of the 3-core cable at the far end are shorted and earthed.

Then resistance between each conductor and earth is measured by a megger. The megger will indicate zero resistance in the circuit of the conductor that is not broken. However, if the conductor is broken, the megger will indicate infinite resistance in its circuit

Short circuit fault

Two conductors of a multi-core cable come in electrical contact with each other due to insulation failure, it is called short-circuit fault. The two terminals of the megger are connected to any two conductors.

The megger gives zero reading, it indicates short-circuit fault between these two conductors. The same step can be repeated for other conductors taking two at a time.

Earth fault

The conductor of the cable comes in contact with earth, it is called earth fault or ground fault. To identify this fault, one terminal of the megger is connected to the conductor and the other terminal connected to earth. Megger indicates zero reading, it means the conductor is earthed. The same procedure is repeated for other conductors of the cable.

INTERNET OF THINGS

The evaluation of IOT in the electrical Power Industry transformed the way things performed in usual manner. IOT increased the use of wireless technology to connect power industry assets and infrastructure in order to lower the power consumption and cost.

The applications of IOT are not limited to particular fields, but span a wide range of applications such as energy systems, homes,

industries, cities, logistics, health, agriculture and so on.

Power grids are now been considered to be one of the vital components of infrastructure on which the modern society depends. It is essential to provide uninterrupted power without outages or losses.

It is quiet hard to digest the fact that power generated is not equal to the power consumed at the end point due to various losses. It is even harder to imagine the after effects without power for a minute.

Power outages occur as result of short circuits. This is a costly event as it influences the industrial production, commercial activities and consumer lifestyle. Government & independent power providers are continuously exploring solutions to ensure good power quality, maximize grid uptime, and reduce power consumption. Increase the efficiency of grid operations and eradicate outages, power loss & theft.

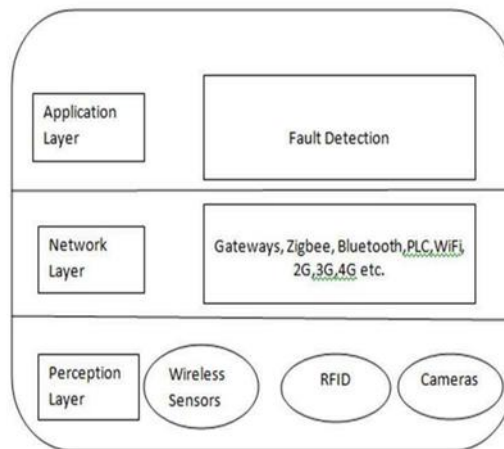

Fig

ONLINE MONITORING OF POWER LINES

As more buildings and areas are being covered with power line systems, the number and severity of power outages become more serious leading to lower system's reliability. Reliability is important as it causes serious negative impacts on public health and economical systems.

Integration of IOT's technology together with the power grid, aims to improve the reliability of power grids through a continuous monitoring of

transmission lines status; in addition to environmental behavior's and consumers activities to send periodic reports to the grid control units.

ONLINE DEMAND- SIDE ENERGY MANAGEMENT

Demand-Side Energy Management (DSM) is the change in consumers energy consumption profiles according to varying electricity price over time, and other payment's incentives from utility

companies. Demand response is used to minimize consumer's electricity bill, shift peak's load demand, minimize operation cost of the power grid, and minimize energy loss and greenhouse's gas emissions.

IOT components collect energy requirements of different home appliances and send them to smart meters. The control unit in smart grid schedules energy consumption of homes' appliances according to the user's preferences in a strategy that minimizes the electricity bill.

PROPOSED SYSTEM

The proposed system is an IoT enabled underground cable fault detection system. The basic principle behind the system is Ohms law. When fault occurs in the cable, the voltage varies which is used to calculate the fault distance. The system consists of Wi-Fi module, Microcontroller, and Real-Time Clock.

The power supply is provided using step- down transformer, rectifier, and regulator. The current sensing circuit of the cable provides the magnitude of voltage drop across the resistors to the microcontroller and based on the voltage the fault distance is located.

Block diagram

A switch connected to a particular phase is closed, the LED connected to the particular phase alone glows. The resistance connected to that particular phase adds up and the voltage drop thus generated is given to Port A of the Microcontroller.

The voltage drop is converted to distance as per Table 1 and is displayed in the LCD. Additionally, the pin of Port C connected to that particular LED goes high and the name of the faulted phase is displayed in the LCD.

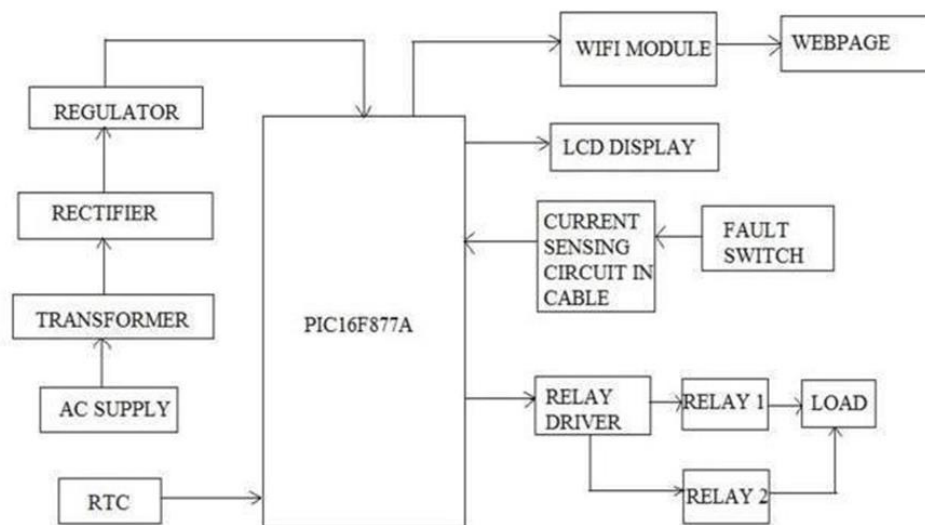

Fig: Block diagram

Circuit diagram

The Real Time Clock DS1307 is connected to Port C of the Microcontroller to display the time at which fault has occurred. For every clock period the time gets incremented. During fault, SCL pin of RTC

synchronizes the data and SDA pin transmits data to the Microcontroller which is displayed in the LCD. The switch over connection is activated during fault period of the cable to transmit uninterrupted power supply.

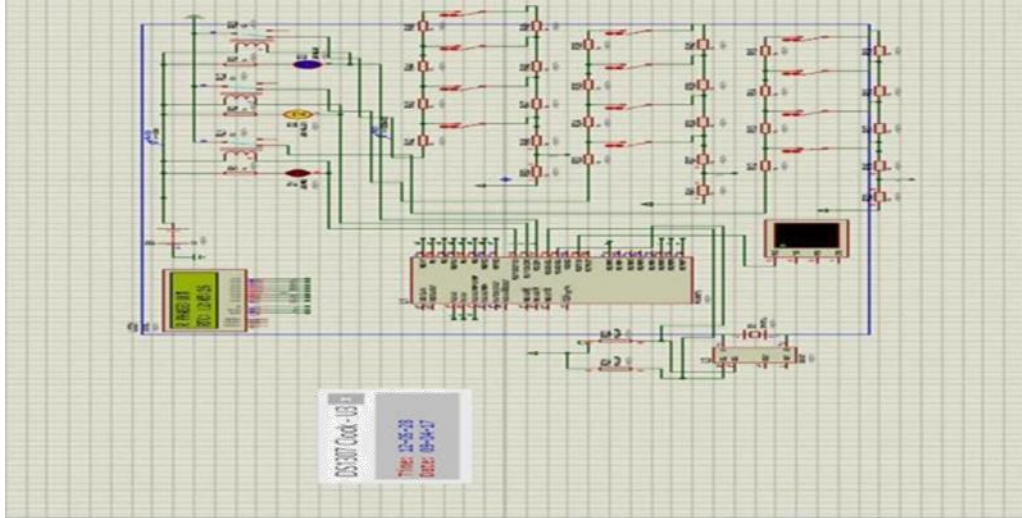

Fig: Circuit diagram

CONCLUSION

The short circuit fault at a particular distance in the underground cable is located to rectify the fault efficiently using simple concepts of Ohms law. The work automatically displays the phase, distance and time of occurrence of fault with the help of PIC 16F877A and ESP8266 Wi – Fi module in a webpage. The benefits of accurate location of fault are fast repair to revive back the power system, it improves the system performance,

it reduce the operating expense and the time to locate the faults in the field.

OBSERVATION AND RESULT

The fault detection system is simulated using Proteus 8.5 professional software and the fault information is displayed in the LCD. The simulation and hardware setup of the fault detection system are respectively. The work IOT Based Underground Cable Fault Detector” is an efficient system as it reduces the time.

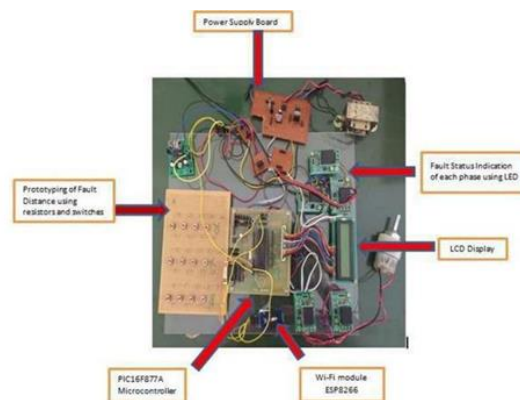

REFERENCES

- [1]. Xiaoning Kang; Xiuda Ma; Shuai Jiang; Xiaoyun Qu, Chao Zhang; Xiaoning Kang; Xiuda Ma; Shuai Jiang; Xiaoyun Qu 2016 IEEE PES Asia-Pacific Power and Energy Engineering Conference (APPEEC)
- [2]. Gilbert Cheung, Yuan Tian, Tobias Neier, Technics of Locating Underground Cable Faults inside conduits, International Conference on Condition Monitoring and Diagnosis IEEE (CMD 2016)

- [3]. Nikhil Kumar Sain, Rajesh Kajla, and Mr.Vikas Kumar, Underground Cable Fault Distance Conveyed Over GSM, International Organization of Scientific Research Journal of Electrical and Electronics Engineering, 11(2), 2016.
- [4]. C.Bharatiraja, S.Jeevananthan, J.L. Munda, A Timing Correction Algorithm based extended SVM for three level Neutral point clamped MLI in Over Modulation Zone IEEE Journal of Emerging and Selected topics in Power Electronics.
- [5]. Manar Jaradat, Moath Jarrah, Abdel Kader Bousseham, Yaser Jararweh, Mahmoud AlAyyoub The Internet of Energy: Smart Sensor Networks and Big Data Management for Smart Grid, Procedia Computer Science Elsevier, 2015.
- [6]. Dhivya Dharani. A and Sowmya. T, Development of a Prototype of Underground Cable Fault Detector, International Journal Electrical, Electronics, and Computer Systems, 2, 2014.
- [7]. Md. Fakhru Islam, Amanullah M T O, Salahuddin. A. Azad, Locating Underground Cable Faults: A Review and Guideline for New Development, 2013 IEEE Conference
- [8]. M.Fonseca_Badillo,L. Negrete_Navarrete,A. Gonzalez_parada,A.Castaneda_Miranda, Simulation and analysis of underground power cables faults, 2012 Elsevier Procedia Engineering
- [9]. Abishek Pandey, Nicolas H. Younan Underground cable fault detection and identification using Fourier analysis, 2010 IEEE Conference
- [10]. Tobias Neier, Cable fault location practical experience,HV Technologies, version-1, 2006.
- [11]. M.S. Choi, D.S. Lee, and X. Yang, A Line to Ground Fault Location Algorithm for Underground Cable System, Korean Institute of Electrical Engineers International Transactions on Power Engineering, 2005, 267-273.
- [12]. K.K. Kuan, Prof. K. Warwick, Real-time expert system for fault location on high voltage underground distribution cables, IEEE Proceedings-C, Volume. 139(3), 1992.