



---

## International Journal of Intellectual Advancements and Research in Engineering Computations

---

### Improvement of coordinated bidirectional overcurrent relay's sensitivity and load restoration time using neuro-fuzzy technique in smart grid

**K Syed Mansoor, Dr P Aravindan**

PG Scholar, Department of Electrical and Electronics, Engineering K.S.Rangasamy College of Technology, Tiruchengode, Tamilnadu, India

Professor, Department OF Electrical and Electronics, Engineering K.S.Rangasamy College of Technology, Tiruchengode, Tamilnadu, India

---

#### ABSTRACT

Protection system for power system has prevailed developed to minimize the damage and to make sure supply in safe condition, continuously and economically. Relay is one of the most paramount components in protection system. There are several kinds of relay that each kind has own characteristic. A relay is device that makes a measurement as a supposititious succedaneum receives a signal that causes it to operate and to affect the operation of other equipment. It responds abnormal conditions in faulty section of the system with the minimum interruption of supply. Protection of distribution networks is one of the most paramount issues in power systems. Overcurrent relay is one of the most commonly used protective relays in these systems. There are two types of settings for these kinds of relays: current and time settings. A opportune relay setting plays a crucial role in reducing undesired effects of faults on the power systems. Overcurrent relays commonly have plug setting (PS) ranging from 50 to 200% in steps of 25%. The PS shows the current setting of the overcurrent relays. For a relay installed on a line, PS is defined by two parameters: the minimum fault current and the maximum load current. However, the most paramount variable in the optimal coordination of overcurrent relays is the juncture multiplier setting (TMS). The proposed work is on bi-directionally communicated directional overcurrent relay protection scheme for perspicacious grid which is supplied by multiple renewable sources under islanded mode. Antecedent work has prevailed gone in protection coordination based on the bi-directional relay utilizing Neuro-Fuzzy control technique. As still there is a possibility to improve the relay's sensitivity and further reduction of load restoration time can be done from the previous control techniques. The scheme is tested on IEEE 9 bus system equipped with the sundry renewable generation units as well as distribution generation units. To achieve the desired relay sensitivity and load restoration time the neuro-fuzzy control techniques will be used and opportune bi-directional communication is maintained within the relay pairs. So that the power system protection and stability can be improved further. Simultaneously the lifespan of the protective relay can be improved by the prevention of false tripping. Simulations are verified by using of MATLAB/Simulink.

**Terms:** Protection Coordination; Directional Overcurrent Relay; Neuro-Fuzzy Techniques; ANFIS; Smart Grid, IEEE 9 bus system

---

#### INTRODUCTION

Albeit DOCRs have nonlinear characteristic curves (nonlinear function), the coordination is

carried out as a linear quandary. This is by virtue of the coordination of a pair of relays is performed based on one point, which is the maximum coordination current of the pair of relays.

---

#### Author for correspondence:

Department of Electrical and Electronics, Engineering K.S.Rangasamy College of Technology, Tiruchengode, Tamilnadu, India

Consequently, the relays guarantee coordination at this point; however, there may be a loss of coordination for faults that are located far from this point. Over the past decades, manual coordination of DOCRs has prevailed the most prevalent practice performed by protection experts. However, due to its complexity and nonlinearity, manual coordination has prevailed formulated as an optimization quandary. Several optimization methods have prevailed proposed to attack this quandary. Coordination of DOCRs in the frame of deterministic optimization theory utilizing linear programming (LP) was an approach first reported in 1988. The quandary was presented as a linear function in which dials were computed for given values of pickup currents. LP was then studied more for this quandary due to its simplicity. Heuristic methods, such as the genetic algorithm (GA) and particle swarm optimization (PSO) of the artificial intelligence (AI) family have expeditiously gained popularity in solving coordination quandaries. GA has prevailed frequently reported in different literatures due to its simplicity, robustness and facile implementation. This algorithm is based on the evolutionary ideas of natural selection of genes which consist of selection, reproduction and mutation. In this case, the quandary was presented as a nonlinear function in which both the dial and the pickup current parameters were computed.

Recently, hybrid methods have withal arisen in solving coordination quandary [11]. Their main attractions are the reduction of search space, execution juncture and the number of iterations required in encountering the solution. The hybrid GA and mixed PSO are newly developed methods that are combined with LP, in which their search space is drastically reduced by encoding only the pickup currents as input variable strings, leaving the dials as task for LP to solve. In other words, these hybrid methods solve coordination quandaries by the linearization of the relay function. Coordination of DOCRs considering different network topologies has prevailed reported in different occasions. A set of relay settings are encountered which will gratify the coordination constraints of different cases of the network topology. On the other hand, the authentic juncture coordination proposed in this thesis is not to find a set of relay settings that will gratify the

coordination constraints of different cases of the network topology, but to re-coordinate all DOCRs for every change of network topology. The advantages by doing so are minimum relay operation juncture, increment of sensitivity, and the facility to withstand another unknown contingency. Moreover, the conception is to coordinate DOCRs online, which as a result enhances in meeting the fundamental requirements of the DOCRs. The ant colony optimization (ACO) has not prevailed implemented in the coordination study but has lately prevailed used for the study of reactive power flow planning, power flow economic dispatch, power generation scheduling, and has reported to be a puissant tool in solving complex quandaries in different areas. The advantage of this algorithm compared to GA is the role of global recollection played by pheromone matrix which leads to better and faster solution convergence. The differential evolution (DE) is a family of the evolutionary algorithm (EA). But compared to most other EAs, de is much simpler and more straightforward to implement. Main body of the algorithm takes four to five lines to code in any programming language. The DE is studied and compared with other algorithms, the gross performance of the DE in terms of accuracy, convergence speed, and robustness makes it very attractive for applications to real-world optimization quandaries, where finding an approximate solution in reasonable amount of computational juncture is much weighted. Hence, it is a novel conception in this thesis to formulate the coordination quandary utilizing ACO and DE. The GA, which is widely kenneed in the coordination area, is used as the comparison reference the fault is located behind the relay, then no operation will take place. But if the fault is located in front of the relay, a comparison of fault magnitude and reference current will take place in order to make the decision whether to operate or not.

### **Indicator of Fault Locations**

The exceeding of actual sensed current from the reference current is called fault or short circuit current. It is an indicator used to identify the fault location. But the fault current depends on the pre-fault voltage and Thevenin's impedance at the fault point (distance). The further the fault is located from the source the bigger the impedance between

the fault and the source, consequently, the smaller the fault magnitude. It is illustrated in Figure 1 that

the fault **F1** which is located nearby bus 2 has a fault magnitude of 13,000 a while Figure 1

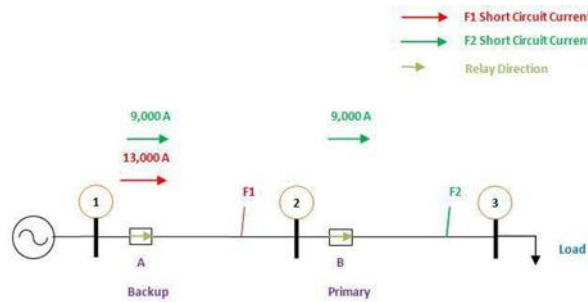

**Figure 1 Indicator of fault locations: ISC**

## DIRECTIONAL OVERCURRENT RELAY

Lines are protected by overcurrent, distance, or pilot relays, depending on the requirements. Overcurrent relay is the simplest and cheapest, the most arduous to apply, and the quickest to need readjustment or even replacement as a system change. It is generally used for phase and ground fault protection on station accommodation and distribution circuits in electric utility and in industrial systems, and on some sub transmission lines where the cost of distance relay cannot be justified. It is withal used for primary ground fault protection on most transmission lines where distance relays are used for phase faults, and for ground backup protection on most lines having pilot relaying for primary protection.

It is generally the practice to use a set of two or three overcurrent relays for protection against inter-phase faults and a separate overcurrent relay for single phase to ground faults. Separate ground relays are generally favoured by virtue of they can be adjusted to provide faster and more sensitive protection for single phase to ground faults than the phase relays can provide. However, the phase relays alone are sometimes relied on for protection against all types of faults. On the other hand, the phase relays must sometimes be made to be inoperative on the zero-phase sequence component of ground fault current.

The directional overcurrent relays are designed to sense the actual operating conditions on an electrical circuit and trip circuit breakers when a

fault is detected. Phase relationship of voltage and current are used to determine the direction to a fault. The relay first discriminates whether the fault is located in front of as a supposititious succedaneum behind the relay. If fault **F2** which is located nearby bus 3 has a fault magnitude of 9,000 a. Both relay **A** and **B** optically discern the same fault magnitude for faults **F1** and **F2**. this is very paramount, as this concept is latterly used in coordination of overcurrent relays in a radial system. Keep in mind that there are occasions when the primary and backup relays sense different fault magnitudes. This is due to in feed effect and will be presented afterwards. Note that faults **F1** and **F2** in Figure 1 and Figure 2 are not simultaneous and the relays used are non-directional due to the reason that they are in a radial system

## COORDINATION OF DIRECTIONAL OVERCURRENT RELAYS

"Coordination" can withal be kened as "selective setting". When the directional overcurrent relays (DOCRs) are implemented on the lines they can offer protection to adjacent lines, buses, transformers, motors etc. The overcurrent relays' settings must ensure that the primary protection has enough juncture to clear the fault in its protected zone afore the backup comes in. A backup device that should not trip "selects" with the downstream device that is close to the fault. The downstream device that is closer to the fault and should trip "coordinates" with the backup device that should not trip. Coordination on

feeders or radial lines is the same, except that it moves only in one direction: from the power source to the loads. The conception of coordination of DOCRs in radial system is illustrated in figure 1. Coordination a mesh system will be explained utilizing Figure 2. Relays **R12**, **R23** and **R31** are in clockwise direction. **R12** offers backup for **R23**, **R23** offers backup for **R31** and **R31** offers backup for **R12**. By doing so the clockwise coordination circle is closed. Meanwhile relays **R21**, **R13** and **R32** are in anticlockwise direction. **R21** offers backup for **R13**, **R13** offers backup for **R32** and **R32** offers backup

for **R21**. Then the anticlockwise coordination circle is closed too. Note that each relay functions as primary for faults in its own zone and backup for adjacent zone. for convenience, the relay names are no longer named with alphabets **A**, **B**, **C**, **D** as in a radial system but by location of each relay. This is due to the reason that a ring fed system can consist of hundreds of relays, so it will be very advantageous if each relay reveals its location in the network. For example, **R12** represents relay connected near bus 1 facing bus 2.

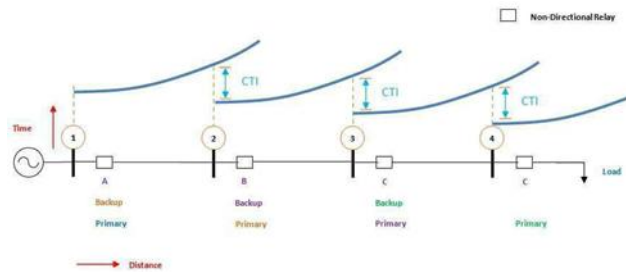

**Figure 2 Coordination of DOCRs in a radial system.**

Similarly, **R21** represents relay connected near bus 2 facing bus 1, and so on. the conception is to set the protection to operate as expeditious as possible for faults in its primary zone, and yet delay sufficiently for faults in its backup zones" or "the process to decide the sequence of the relay operations for each possible fault location and to provide sufficient coordination margins without excessive juncture delay, taking into account the desired protection qualities of selectivity, reliability, sensitivity, and speed". In a radial system it is recommended to start the coordination from the relay nearest to the load toward the source. On the other hand, there is no such recommendation in a mesh system but arbitrary optate a start point and coordinate the relays. This might result to a deplorable coordination at the moment closing the mesh system, meaning the last relay which must be coordinated with the first relay that was chosen as start point do not gratify the coordination conception. in other words, the first relay that was chosen as the start point fails to offer backup for the last relay that was to be coordinated with at the moment of closing the ring fed system. This is very prevalent scenery, so if it transpires one must start the coordination all over

again from selecting a incipient start point. As a result, optimization algorithms were implemented to eschew the repetitive and extreme juncture consumption of coordinating a mesh system.

### Adaptive neuro-fuzzy inference system

To overcome these problems, researchers used intelligent methods like FLC (Fuzzy Logic Control), ANN, (Artificial Neural Networks), etc. In order to bring together the benefits of Fuzzy Logic and ANN methods, these commands were combined in a single bloc named ANFIS (Adaptive Neuro-Fuzzy Inference System) which provide better efficiency with preferred accuracy and speed. [16-20]

Adaptive network-based fuzzy inference system (ANFIS) is an adaptive network which allows the application of neural network topology together with fuzzy logic. An Adaptive Neuro-Fuzzy approach combines these two methods and uses the advantages of both methods. It is capable of handling complex and nonlinear problems. ANFIS is a class of adaptive multi-layer feed-forward networks that is functionally equivalent to a fuzzy inference system. It implements a Takagi-Sugeno fuzzy inference system and has a five layered architecture as shown in Figure 3.

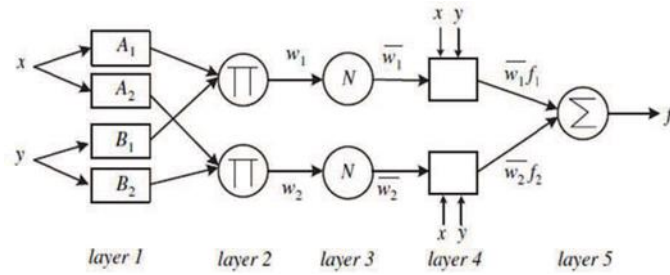

Figure 3 ANFIS architecture based on Takagi-Sugeno

Analyzing the mapping relation between the input and output data, ANFIS can establish the optimal distribution of membership functions using either a back-propagation gradient descent algorithm alone or in combination with a least-squares method. More details about ANFIS, layers and training methods of ANFIS can be found in [16-20].

**PROPOSED METHODOLOGY**

The main obligation of protective relays is to detect the faults and clear them in minimum juncture by sending the "open" signal to the circuit breakers. OC relay is one of the most prevalent by virtue of its simplicity and economic features. It has prevailed used as the main relay to bulwark the sub transmission and distribution systems or as backup protection of the transmission system. Both the main and backup relays detect and sense the fault as anon as it occurs. However, the primary relay is the first one which should clear the fault and the backup relay would take over tripping with a pre-determined juncture interval with the operation juncture (OT) of the main relay only if the primary relay does not eliminate the fault in its specific juncture. The

minimum OT of a backup relay should be more than the total of the related main relay OT, main circuit breaker OT, and overshoot juncture of the backup relay. Hence, the OC relays coordination can be considered a significant concern for power systems protection.

The settings of OC relays include plug setting multiplier (PSM) and juncture setting multiplier (TSM), which should be calculated such that the faulty part of the network is disconnected. Generally, in traditional OC relays, the rating of PSM is from 50 to 200% in steps of 25% and the rating of TSM is from 0. 05 to 1 in steps of 0. 05. However, these parameters can be set in a step of 0. 01 in digital relays. PSM is determined based on the minimum fault current and the maximum load current. The coordination of OC relays in a radial network is genuinely simple, since each relay is the backup for its downstream relays, while in interconnected networks each relay may be a backup for more than one relay and withal several relays can be the backup for one relay. Albeit OC relays have a simple structure, their coordination can be an intricate quandary in some interconnected networks.

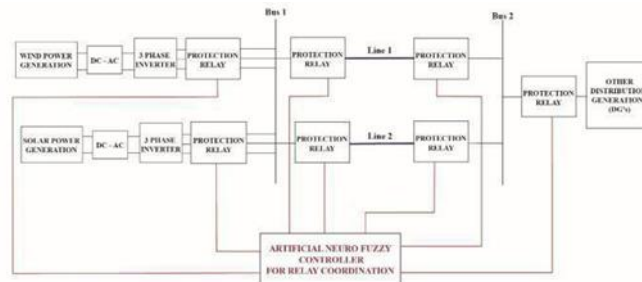

Figure 4 The Block Diagram of Proposed Methodology

This quandary would become more complex if the size and complexity of the system increases. It should be noted that in the interconnected system the directional OC relays should be used, which is simply addressed by the OC relay in this paper. The traditional methods [1], [2] for overcurrent relays coordination in interconnected networks are juncture consuming considering the astronomically immense amount of calculation burden and the arduousness of determining the power system break point. Diverse ranges of optimization methods and approaches have prevailed proposed to achieve not only the coordination between the relays but withal the optimal operation juncture of the protection system. The objective functions used in these methods have some drawbacks related to operation juncture of relays and their coordination. The proposed method integrates the renewable energy sources like wind, solar power, other DG's and supplies the power to the load. The load is supplied by integrated renewable energy source i.e. the supply from wind and solar PV. At this instant the load supplied by the grid is equal to the power delivered by the DG's to the grid. In any instant the relay may leads to false tripping due to any impulse overcurrent fluctuation, which may lead to disconnection of nearby DG's and also overload the active DG's to supply the entire load. This makes the system instable and leads to damages of all the equipment's connected along the active DG's [6]. To prevent the DG's from this problem the entire protective relays in the system is controlled by the neuro-fuzzy controller as shown on figure 4. All the relays connected in the system are communicated bi-directionally and the controller decides which protective relay should trip for the corresponding problem. The time taken for the restoration of the load or DG's are also be monitored and bring controlled by the neuro-fuzzy controller.

This make the protective system reliable and even more sensitive from bring false tripped.

## PROPOSED SIMULINK MODEL

Simulink, developed by math works, is a graphical programming environment for modelling, simulating and analysing multi domain dynamical systems. Its primary interface is a graphical block diagramming tool and a customizable set of block libraries. It offers tight integration with the rest of the MatLab environment and can either drive MatLab or be scripted from it. Simulink is widely used in automatic control and digital signal processing for multi domain simulation and model-based design. Simscape power systems (previously simpower systems) offers part libraries and analysis tools for modelling and minizing electrical power systems.

It consists of designs of electrical power parts, consisting of three-phase devices, electrical drives, and parts for applications such as versatile A/C transmission systems (FACTS) and renewable resource systems. Harmonic analysis, computation of overall harmonic distortion (THD), load circulation, and other essential electrical power system analyses are automated, assisting you examine the efficiency of your style. You can incorporate mechanical, hydraulic, thermal, and other physical systems into your design utilizing elements from the simscape household of items. To release designs to other simulation environments, consisting of hardware-in-the-loop (HIL) systems, simscape power systems supports c-code generation. Utilizing the processor-based technique, a library including comparable designs for power electronic devices is readily available for customizing a simscape power systems design to enable real-time-capable code generation on real-time processors by ways of Simulink coder

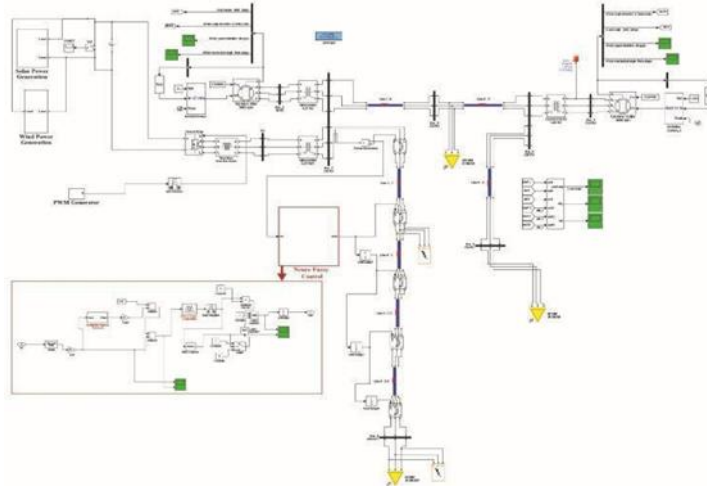

**Figure 5 Proposed Simulink Model using IEEE 9 bus system**

The MatLab model of the proposed model has illustrated in Figure 5. It consists of hybrid renewable energy sources i.e., combination of both wind and solar PV system addition to the sundry distributed generators **G1** and **G2** connected to power grid. The load is supplied by sundry sources like hybrid renewable energy sources and distributed generation (**G1 & G2**). In case of false tripping of any relay due to sudden impulse current and loss of coordination of relay communication, the load is supplied by the other generation units which cause overloading quandary. For preventing those units from being overloaded and for maintaining the opportune communication between the relays the fuzzy logic controller is being used as illustrated in Figure 5. For reduction in the system restoration juncture after the relay tripping

a PID controller is used as illustrated in the Figure 5

## RESULTS AND DISCUSSION

The improvement of relay sensitivity is done by measuring the current flow in the grid and analysing whether the measured value is a fault current value or any impulse value of current occurred due to any external reason. This is done by the ANN controller which predicts the actual fault current flow. This is compared with the predetermined value of current in the fuzzy logic controller, if the fault current reaches the predetermined value the fuzzy will delivers a tripping signal to the relay which is nearby to the fault location and prevents the tripping of other relays.

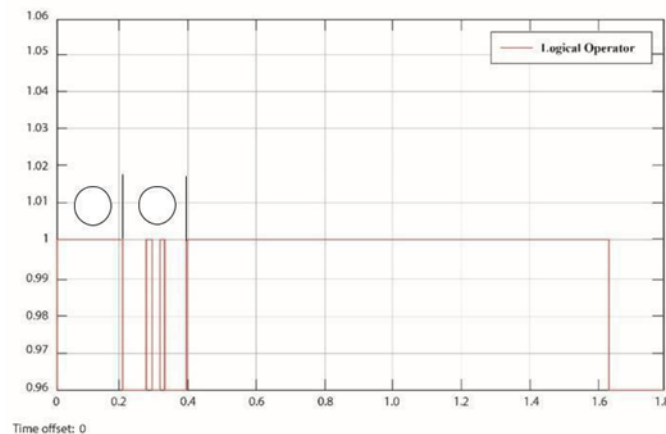

**Figure 6 Relay tripping during fault current flow**

The Figure 6 illustrates the relay operation for the fault current. The zone 1 determines that the relay is in closed condition and the generation unit is supplying the power to the grid.

The beginning of the zone 2 determines that the relay is in open condition due to flow of fault current in the power grid.

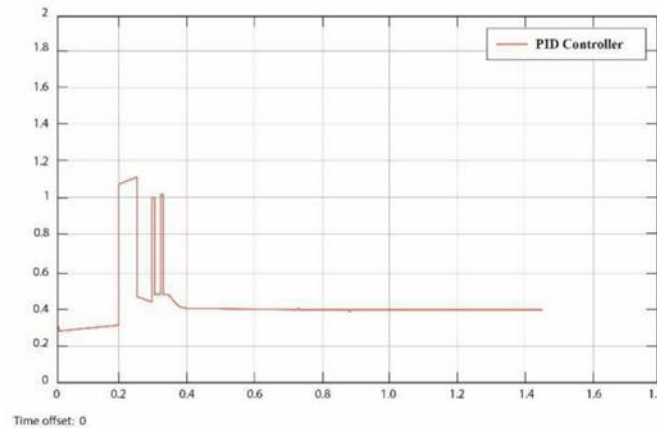

**Figure 7 PID control for load restoration**

During the zone 2 period, the Fuzzy and PID controller together tries to reconnect the disconnected system to the power grid. But due to the fault current level it fails to reconnect the disconnected system. After the expeditious replication of the relay, the juncture taken to the restoration is being reduced and the PID controller coordinates in the reduction of time taken for the system restoration as illustrated in the Figure 7. The entire output of relay's sensitivity (i.e., tripping time of the relay) and time take for the

restoration of the load is compared with the previous control process (i.e., Fuzzy Control) [1]. It is found that, there is an improvement in the relay's sensitivity and load restoration time using this Neuro-Fuzzy control technique. For further increase in the power rating of the system and control techniques for the future extension, these parameters can be used as the forecasted data and the Artificial Intelligence technique can be used efficiently.

## REFERENCES

- [1]. K. Syed Mansoor, Dr. P. Aravindan, 'Improvement of coordinated Bidirectional Overcurrent Relay's Sensitivity and Load Restoration Time Using Neuro-Fuzzy Technique in Smart Grid', International journal of Advanced Research in Electrical, Electronics and Instrumentation Engineering, 20, 2019.
- [2]. Albasri, F., Alroomi, A., Talaq, J. 'Optimal coordination of directional overcurrent relays using biogeography-based optimization algorithm', IEEE Transaction on Power Delivery, 2015.
- [3]. Amraee, T, "Coordination of directional overcurrent relays using seeker algorithm", IEEE Transaction on Power Delivery., 27(3), 2012, 1415–1422.
- [4]. Anang Tjahjono, Dimas O. Anggriawan, Alfa K. Faizin, Ardyono Priyadi, Margo Pujiantara, TaufikTaufik, Mauridhi Hery Purnomo, "Adaptive modified firefly algorithm for optimal coordination of overcurrent relays", IET Generation, Transmission & Distribution, 2017
- [5]. Ankita sharma, deepa kiran, "planning the coordination of overcurrent relay for distribution systems considering network reconfiguration and load restoration", IET Generation, Transmission & Distribution, 2017
- [6]. Costa, M.H., Saldanha, R.R., Ravetti, M.G., 'Robust coordination of directional overcurrent relays using a meta-heuristic algorithm', IET Generation, Transmission & Distribution, 11(2), 2017, 464– 474

- [7]. Kamel A, M.A. Alaam, A.M. Azmy and A.Y. Abdelaziz, "Protection Coordination for Distribution Systems in Presence of Distributed Generators," *Electric Power Components and Systems*, 41(15), 2013, 1555-1566.
- [8]. Khaled A. Saleh, H. H. Zeineldin, A. Al-Hinai, Ehab F. El-Saadany "Optimal Coordination of Directional Overcurrent Relays Using a New Time-Current- voltage Characteristic", *IEEE TRANSACTIONS ON POWER DELIVERY*, 30(2), 2015.
- [9]. Lukasz huchel, hatem H, Zeineldin, "Planning the Coordination of Directional Overcurrent Relays for Distribution Systems Considering DG", *IEEE Transaction on smart grid*, 2015.
- [10]. M.M. Eissa, "Protection techniques with renewable resources and smart grids – A survey", *Renewable and Sustainable Energy Reviews*, 52, 2015, 1645-1667.
- [11]. Manohar Singh, M., Panigrahi, B.K., Abhyankar, A.R. 'Optimal coordination of directional over-current relays using teaching learning-based optimization (TLBO) algorithm', *Int. J. Electr. Power Energy Syst.*, 50, 2013, 33-41.
- [12]. Meng yen shih, Arturo conde, "an adaptive overcurrent coordination scheme to improve relay sensitivity and overcome drawbacks due to distributed generation in smart grids", *IEEE Transaction on Industrial Applications*, 2016.
- [13]. Reza Mohammadi, hossein Askaraian Abyaneh, Hossien Mahdinia Rudsari, Saied Hamid Fathi, Hasan Rastegar, "overcurrent relays coordination considering the priority of constraints", *IEEE Transaction on Power Delivery*, 26(3), 2011.
- [14]. Sharaf H.M, "protection coordination of microgrids with grid-connected and islanded capabilities using communication assisted dual setting directional overcurrent relays", *IEEE Transaction on Smart Grid*, 2016.
- [15]. Tjahjono, A., Anggriawan, D.O., Faizin, A.K., 'Adaptive modified firefly algorithm for optimal coordination of overcurrent relays', *IET Gener. Transm. Distrib.*, 11(10), 2017, 2575-2585.
- [16]. W. El-khattam T.S. Sidhu, "Resolving the impact of distributed renewable generation on directional overcurrent relay coordination: a case study", *IET Renewable Power Generation*, 9, 2008.
- [17]. J.S.R. Jang, R. May, ANFIS: Adaptive network based fuzzy inference systems, *IEEE Trans. Syst. Man Cybern.* 23, 1993, 665-685.
- [18]. Jang, J.S.R., C.T. Sun, Neuro-fuzzy modeling and control, Special Issue on Fuzzy Logic in Engineering Applications, *Proceedings of the IEEE* 83(3), 1995, 378-406.
- [19]. J.S.R. Jang, C.T. Sun, E. Mizutani, *Neuro-Fuzzy and Soft Computing*, Prentice Hall, 19, 1997, 510-514.
- [20]. R. Babuska, *Fuzzy Modeling for Control*, Kluwer Academic Publishers, Boston. 1998.
- [21]. H. Bunke, A. Kandel, *Neuro-Fuzzy Pattern Recognition*, World Scientific Publishing, Singapore, 2000.