



International Journal of Intellectual Advancements and Research in Engineering Computations

IOT based Home Security System using PIR Sensor, GSM and Camera with Message Alert

Ms. N. Zahira Jahan¹, Mr. S. Dhivakar²

¹Associate Professor, Department of MCA, Nandha Engineering College (Autonomous), Erode-52.

²Student, Final M.C.A, Nandha Engineering College (Autonomous), Erode-52.

ABSTRACT

Nowadays using Internet of Things (IoT) different types of home security system used to protect home from intruder and thief. There are many sorts of fine security systems and cameras out there for home security however they're a lot of pricey, therefore these days we'll build an occasional price easy Home Security System exploitation Home Security System using PIR Sensor, Camera and GSM with Message Alert, which not only alert user through an message but also sends the picture of Intruder when it detects humans. This system will detect the presence of intruder and quickly alert the user by sending him an alert message. The picture of the Intruder, captured by camera. Arduino is used to control the whole system. This system can be installed at the main door of home or office and can monitor it from anywhere in the world using message. A PIR sensor is used to detect the presence of any person and a Camera is used to capture the images when the presence is detected. PIR Sensor triggers the Camera through Arduino. Arduino sends commands to camera to click the picture and save it. After that, images are saved in google photo's through wifi modules. Then GSM module sends photo storage link as message to the user.

Index Terms: Internet Of Things, Home Security System, PIR Sensing, Message Alert.

INTRODUCTION

ACCORDING to research, in the world of Internet Of Things(IoT) when we have all the technologies to revolutionize our life, it's a great idea to develop new automated systems. Generally, IoT is used in home automation refers to handling and controlling home appliances by using micro-controller or computer technology. Automation is popular now days because it provides ease, security and efficiency. A sensor senses the status of appliances and updates to web server. If user is far away from home, he can access and change status of appliances i.e. switches it on/off. Likewise, there are many types of good security systems and cameras out there for home security

but they are much expensive. This paper will describe approach of building a low cost simple

Home Security System using PIR Sensor and Camera with Message Alert which not only alert user through a message but also sends the picture of Intruder when it detects any.

RELATED WORK

Home Security Alarm Systems area unit vital in gift day society, wherever crime is increasing. With the technological advancements we've got achieved within the recent years, a home owner doesn't got to worry concerning home security whereas obtaining off his/her home. fashionable home security systems give enough security from burglars, fire, smoke, etc. They conjointly give immediate notification to the house owner..

Author for correspondence:

Department of MCA, Nandha Engineering College (Autonomous), Erode-52.

A day several comes like to implement a straightforward and cheap, however economical home security alarm accessible in market is intended for detection intruders and informing the owner by creating a telephone.

A stealer Alarm – is essentially associate degree interloper alarm or associate degree opposing thievery alarm victimization Arduino and PIR sensing element. it's potential to boost with several options like adding a GSM module to send SMS alerts to fixed mobile numbers once associate degree interloper is detected (when a motion is detected within the vary of PIR sensor). [1-5]

HOME SECURITY SYSTEM USING PIR SENSOR AND GSM AND CAMERA WITH MESSAGE ALERT

Requirements

- Arduino uno
- PIR sensor
- Ov7670 Camera Module
- Bread Board
- GSM Module
- WIFI Module
- Jumper Wires

Arduino UNO

The Arduino UNO is AN ASCII text file microcontroller board supported the semiconductor ATmega328P microcontroller and developed by Arduino.cc. The board is supplied with sets of

digital and analog input/output (I/O) pins that will be interfaced to numerous growth boards (shields) and alternative circuits. The board has fourteen Digital pins, six Analog pins, and programmable with the Arduino IDE (Integrated Development Environment) via a kind B USB cable. It are often supercharged by a USB cable or by AN external nine potential unit battery, although it accepts voltages between seven and twenty volts. it's conjointly kind of like the Arduino Nano and designer. The hardware reference style is distributed beneath an inspired Commons Attribution Share-Alike two.5 license and is on the market on the Arduino web site. Layout and production files for a few versions of the hardware also are out there. The Uno board and version one.0 of Arduino software system (IDE) were the reference versions of Arduino, currently evolved to newer releases. The Uno board is that the initial during a series of USB Arduino boards, and therefore the reference model for the Arduino platform. The ATmega328 on the Arduino Uno comes preprogrammed with a boot loader that permits uploading new code thereto while not the utilization of AN external hardware applied scientist. It communicates exploitation the initial STK500 protocol. The Uno conjointly differs from all preceding boards in this it doesn't use the FTDI USB-to-serial driver chip. Instead, it uses the Atmega16U2 (Atmega8U2 up to version R2) programmed as a USB-to-serial convertor.

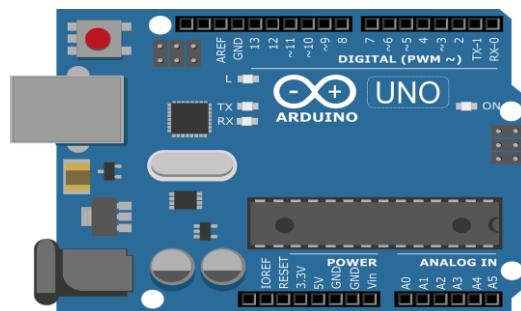

Fig. 1 Arduino Uno

PIR sensor

A private PIR detector detects changes within the quantity of infrared emission happening upon it, that varies betting on the temperature and surface characteristics of the objects ahead of the detector. once AN object, like a personality's, passes ahead of the background, like a wall, the temperature at that time within the sensor's field of read can rise from temperature to temperature, and so back once more. The detector converts the ensuing modification within the incoming infrared emission into a modification within the output voltage, and this triggers the detection. Objects of comparable temperature however totally different surface characteristics may additionally have a unique actinic ray pattern, and therefore moving them with reference to the background might trigger the detector furthermore.

PIRs are available in several configurations for a large type of applications. the foremost common models have various Fresnel lenses or mirror segments, a good vary of regarding 10 meters

(thirty feet), and a field of read but one hundred eighty degrees. Models with wider fields of read, together with 360 degrees, area unit available—typically designed to mount on a ceiling. Some larger PIRs area unit created with single section mirrors and may sense changes in infrared energy over thirty meters (one hundred feet) aloof from the PIR.

The housing can sometimes have a plastic "window" through that the infrared energy will enter. Despite usually being solely clear to actinic ray, infrared energy is ready to succeed in the detector through the window as a result of the plastic used is clear to infrared emission. The plastic window reduces the possibility of foreign objects (dust, insects, etc.) from obscuring the sensor's field of read, damaging the mechanism, and/or inflicting false alarms. The window is also used as a filter, to limit the wavelengths to 8-14 micrometres, that is nearest to the infrared emission emitted by humans. it's going to additionally function a focusing mechanism.

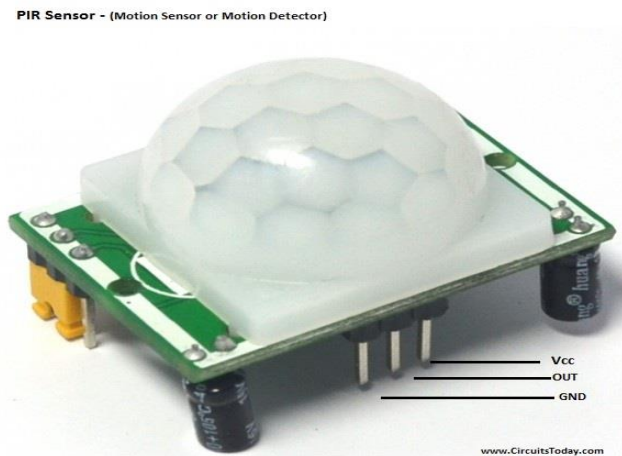

Fig. 2 PIR Sensor

OV7670 camera modules

The OV7670 could be a low voltage CMOS image device that has the complete practicality of a single-chip VGA camera and image processor in an exceedingly tiny footprint package. The OV7670 provides full-frame, sub-sampled or windowed 8-bit pictures in an exceedingly wide selection of formats, controlled through the Serial

Camera management Bus (SCCB) interface. it's image array capable of operative at up to thirty frames per second (fps) in VGA with complete user management over image quality, info and output information transfer. All needed image process functions, together with exposure management, gamma, white balance, color saturation, hue management and additional, also

are programmable through the SCCB interface. additionally, Omni Vision Camera chips use proprietary device technology to enhance image quality by reducing or eliminating common lighting/electrical sources of image contamination like fastened pattern noise, smearing blooming to supply a clean, absolutely stable color image.

Features

- High sensitivity appropriate for low lightweight operation
- Low voltage appropriate for embedded applications
- Standard SCCB interface compatible with I2C interface
- Supports VGA, CIF, and from a spread of sizes CIF to 40x30
- VarioPixel sub-sampling mode
- ISP incorporates a compensation perform to eliminate noise and dead pixels
- Support for image scaling
- Compensation for loss of lens



Fig 3. OV7670 Camera Module

Bread board

A bread board could be a construction base for prototyping of natural philosophy. Originally it absolutely was virtually a bread board, a elegant piece of wood used for slicing bread. In the Nineteen Seventies the solder less bread board (a.k.a. plug board, a terminal array board) became out there and these days the term "breadboard" is often accustomed discuss with these.

A result of the solderless bread board does not need bonding, it's reusable. This makes it simple to use for making temporary prototypes and experimenting with circuit style. For this reason, solderless breadboards also are popular students and in technological education. Older bread board sorts didn't have this property.

A strip board (Veroboard) and similar prototyping computer circuit boards, that square

measure accustomed build semi-permanent soldered prototypes or one-offs, cannot simply be reused. a range of electronic systems could also be prototyped by exploitation breadboards, from little analog and digital circuits to complete central process units .

A "full size" terminal bread board strip generally consists of around fifty six to sixty five rows of connectors, every row containing the preceding 2 sets of connected clips (A to E and F to J). in conjunction with bus strips on all sides this makes up a typical 784 to 910 tie purpose solderless bread board. Miniature solderless breadboards as little as seventeen rows (no bus strips, a hundred and seventy tie points) is found, however these square measure solely appropriate for small and straightforward styles.

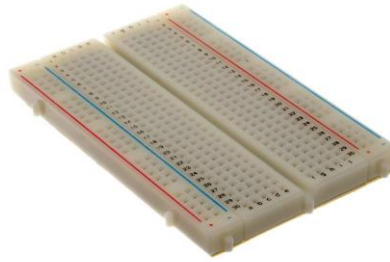

Fig 4. Bread Board

GSM modules

Features

- Improved spectrum potency
- International roaming
- Compatibility with integrated services digital network (ISDN)
- Support for brand spanking new services.
- SIM phone book management
- Fixed dialing range (FDN)
- Real clock with alarm management

- High-quality speech
- Uses coding to create telephone call

Testing of code

- Insert the SIM card.
- Upload Code with removed RX, TX lines.
- Turn on Both Arduino and GSM Modem.
- User will receive SMS after 15 Seconds. If it takes too long to register on network increase the 10 seconds delay to larger value.



Fig 5. GSM Modules

Wi-Fi modules

The ESP8266 could be a inexpensive Wi-Fi semiconductor with full TCP/IP stack and microcontroller capability made by manufacturer Espressif Systems in Shanghai, China. The chip initial came to the eye of western manufacturers in August 2014 with the ESP-01 module, created by a third-party manufacturer Ai-Thinker. This tiny module permits microcontrollers to attach to a Wi-Fi network and build straightforward TCP/IP

connections mistreatment Hayes-style commands. However, initially there was nearly no English-language documentation on the chip and therefore the commands it accepted. The terribly low worth and therefore the proven fact that there have been only a few external parts on the module, that advised that it might eventually be terribly cheap in volume, attracted several hackers to explore the module, chip, and therefore the code thereon, also on translate the Chinese documentation. ESP8266

module is low price standalone wireless transceiver which will be used for end-point IoT developments. to speak with the ESP8266 module, microcontroller must use set of AT commands. Microcontroller communicates with ESP8266-01 module mistreatment UART having such information measure.

ESP8266 comes with capabilities

- 2.4 gigacycle per second Wi-Fi (802.11 b/g/n, supporting WPA/WPA2),

- general-purpose input/output (16 GPIO),
- Inter-Integrated Circuit (I²C) serial communication protocol,
- Analog-to-Digital Conversion (10-bit ADC)
- Serial Peripheral Interface (SPI) serial communication protocol,
- UART (on dedicated pins, and a transmit-only UART will be enabled on GPIO2), and
- Pulse-Width Modulation (PWM).

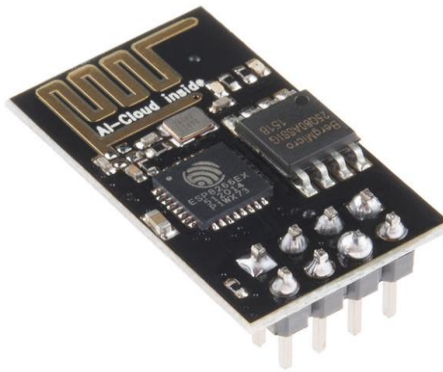

Fig 6. WIFI Module

Otherwise coloured wires and color-coding discipline area unit typically adhered to for consistency. However, the amount of obtainable colours is usually so much fewer than the amount of signal sorts or ways. Typically, many wire colours area unit reserved for the availability voltages and ground (e.g., red, blue, black), some area unit reserved for main signals, and therefore the rest area unit merely used wherever convenient. Some ready-to-use jump wire sets use the colour to point the length of the wires, however these sets don't enable a meaty color-coding schema.

Jumper wires

Jump wires (also known as jumper wires) for solderless bread boarding may be obtained in ready-to-use jump wire sets or may be manually factory-made. The latter will become tedious work for larger circuits. Ready-to-use jump wires are available totally different qualities, some even with little plugs connected to the wire ends. Jump wire material for ready-made or home-cured wires ought to typically be twenty two AWG (0.33 mm²) solid copper, tin-plated wire - presumptuous no little plugs area unit to be connected to the wire ends. The wire ends ought to be stripped 3/16 to 5/16 in (4.8 to 7.9 mm). Shorter stripped wires would possibly end in unhealthy contact with the board's spring clips (insulation being caught within the springs). Longer stripped wires increase the probability of short-circuits on the board. Needle-nose pliers and tweezers area unit useful once inserting or removing wires, significantly on jammed boards.

Jumper wires generally are available 3 versions: male-to-male, male-to-female and female-to-female. The distinction between every is within the finish purpose of the wire. Male ends have a pin jutting and may plug into things, whereas feminine ends don't and area unit wont to plug things into. Male-to-male jumper wires area unit the foremost common and what you doubtless can use most frequently. once connecting 2 ports on a board, a male-to-male wire is want.

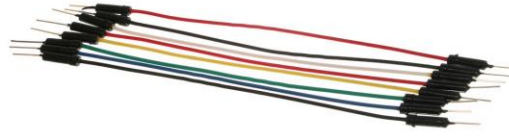

Fig 7. Jumper Wires

METHODOLOGY

- PIR Sensor to Detect Human Presence
- Capturing Photos
- GSM Module to Send SMS Alert

PIR sensor to detect human presence

PIR sensor is sense human being to generate heat of energy. In PIR sensor to be sense to

indicate a Arduinio Uno. PIR sensor detects a human being moving around 10m from the sensor. It is an average value and actual detection range is between 5m and 12m. PIR sensor are made up of Pyro Electric Sensor, it can detect levels of infrared radiation.

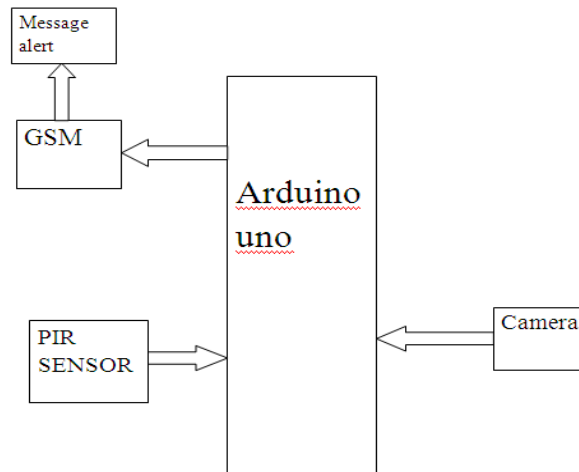

Fig 8. Block Digram

Capturing photos

A PIR sensor is used to detect the presence of any person and a Camera is used to capture the images when the presence it detected. PIR Sensor triggers the Camera through arduino. Arduino sends commands to camera to click the picture and save it PC system. An external oscillator provides the clock source for camera module XCLK pin. The OV7670 camera module is a low cost 0.3 mega pixel CMOS color camera module, it can output 640x480 VGA resolution image at 30fps.

PIR Sensor triggers the Camera through Arduino. Arduino sends commands to camera to click the picture and save it.

GSM module to send SMS alert

The captured image of the person when PIR senses the presence of an individual and our controller sends a image to pre-storing device such as PC. After that, arduino creates a message with link of google photos storage location and sends it to the registered user mobile number through GSM

module. When user opens the link, images will be shown from google photo's storage location.

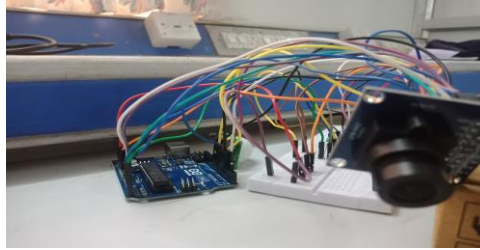

Fig: 9. Home Security System using OV7670 Camera

CONCLUSION

IOT platform provides a simple environment to connect the hardware devices through the user. This low cost system can be installed at the main door of home or office and user can monitor it from anywhere in the world using SMS alert.

Hence, the protection is ensured at home even the owner is out of station. In case of emergency, user using this home security system can alert their neighbors and police. And there is no need of 24/7 recording which is much expensive.

REFERENCES

- [1]. IOT Based Smart Security and Smart Home Automation Sudha Kousalya Assistant Professor Dept. of ECE Aditya College of Engineering Madanapalle ,Chittoor , India.
- [2]. <https://www.engineersgarage.com/contribution/arduino-based-security-system-using-gsm-and-pir-sensor>
- [3]. <https://www.electronicshub.org/arduino-gsm-home-security-alarm-system/>
- [4]. <http://www.circuitstoday.com/burglar-alarm-using-arduino-and-pir-sensor>
- [5]. Anitha A School of Information Technology and Engineering, VIT University, Vellore-632014, Tamil Nadu, India.