



International Journal of Intellectual Advancements and Research in Engineering Computations

Zigbee based wireless boiler parameters control using GSM technology

R.Priyanka¹, S.Ramya¹, A.Suresh¹, R.Meyananth¹, Mr.G.Pradeepkumar²

¹Students, Department of Electronics and Communication Engineering, Nandha Engineering College.

²Assistant Professor, Department of Electronics and Communication Engineering, Nandha Engineering College.

ABSTRACT

In thermal Power Plant as there is regular change in shift of workers, hence it is important to check out all the parameters related with thermal Power Plant. This project develops a sensor network based control. The remote monitoring system is also essential one. In the proposed system Arduino Uno (ATmega328p) is used to controls all sub devices connected across to monitor and control the Boiler parameters such as temperature, water level, and flame. These are measured by pressure sensor, water level sensor and flame sensor. In this system we can also communicate data to other PC_s in remote location using ZigBee technology and also GSM technology.

INTRODUCTION

In India 70% of Power production is form thermal Power Plant. The major part of the thermal Power Plant is the Boilers. The Boiler produces steam [1]. The steam there may arise some problems like increase in temperature, pressure and also increase or decrease in Water level, so theses parameters are to be continuously monitored and should be controlled. This plays an important role in monitoring and controlling the Boiler thereby providing safety to the power plant [2]. Here three sensor namely temperature, pressure sensor to sense the pressure and water level sensor to sense the water level. The sensors are being connected to the microcontroller and forms that board the control actions are being done. If the normal level is being exceeded the control signal is passed and the control is done[3-5]. When the temperature exceeds a certain level then the motor of the conveyor belt is slowed down thereby the coal input to the furnaces being reduced and finally the pressure is reduced. When the level of Water goes high or low then the entire unit is being turned off. This is the process that is carried out in the Plant[6-11].

Introduction to Zigbee

The International standard of ZigBee is IEE 802.15.4 and is developed by ZigBee alliance. The ZigBee is used for high level communication protocols, low-Power digital radios based on IEEE standard for personal area networks. These devices are used in mesh network form to transmit data over longer distances, passing the data through intermediate devices to reach more distance. ZigBee networks will be built ad-hoc, without central control or transmitting high power / receiver power to access all devices.

The main application of ZigBee is that require low data rates, long battery life, and a secure network. ZigBee has a defined rate of 250 Kbit / s, best suited for the duration or transmission of a single signal from a sensor or input device. ZigBee applications for home entertainment and control, wireless sensor and networks, industrial control, embedded experience, medical data collection, automation, etc. ZigBee technology is suited for devices with the simplest construction, low cost, low power and low operating cycle.



Figure 1.1: ZigBee Module

ZigBee chip vendors often sell integrated radios and microcontrollers between 60 KB and 256 KB flash memory. ZigBee operates in the areas of industrial, scientific and medical radio (ISM); 868 MHz in Europe, 915 MHz in the USA and Australia, and 2.4 GHz in many locations around the world. The data transfer rate is in the range from 20 to 900 kilobits / second. ZigBee distance range is 10 to 20 meters.

EXISTING METHOD

The existing projects are that controlling the Boiler parameters by using pic controller. The main disadvantage is the controller sometimes does not act fact, as the processing speed is very slow. The pic based controlling is an old based one which consists of several problems. The second existing project is that the GSM based technology, which does not have the controlling part and consists of only getting the message when the limit exceeds. This advantage whereas only message passing technique is only involved. One has only monitoring and the other existing one has only controlling technique. If both the techniques are involved then it will be a sufficient one. This is the draw backs in the existing systems.

PROPOSED SYSTEM

Boiler is the major part of thermal Power Plant. The manual monitoring and controlling is not possible every time. The automated monitoring

and control process with ZigBee overcomes existing system issues. Here three parameters are being monitored and control actions are being taken. If the current value exceeds certain limit the control signal is being taken placed. The temperature, pressure, and the Boiler water level is understood with the help of sensors and the control actions are being taken placed simultaneously when the limit exceeds. The values are determined with the help of sensors are given first by the microcontroller and necessary coding is being done by which the control actions are done. When the temperature exceeds a certain limit the spray valve is being opened and the water is being sprayed also when the temperature exceeds a certain limit the speed of the motor is being slowed down. When the water is goes low or high then the entire system is being turned off to safeguard the system. Simultaneously the monitoring process is done; also another process is that safety is ensured by enabling password before logging into the monitoring page. The setup provides the protection of the system by monitoring and doing the required control process at a perfect time when the limit exceeds the specified criteria as mentioned.

In transmitter section, we use separate sensors and microcontroller to monitor and graphical user interface for controlling the parameters of Power Plant. After sensing the data, it is given as input for microcontroller. By acquiring the data from the sensors, the microcontroller monitors it. In order to communicate between these two units wireless Zigbee module is used.

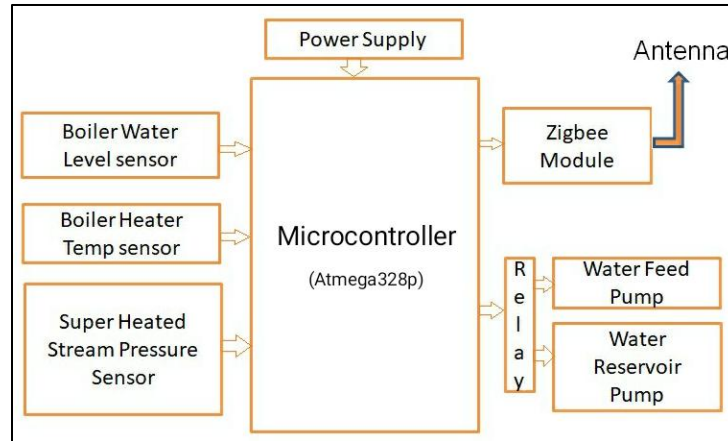

Figure 3.1: Transmitter Block

Transmitter section mainly consists of four sensor networks in this system which senses various parameters in Thermal Power Plant. The Various sensors used here are Temperature, Pressure, Level and Flame Sensors. As the output through these sensors is a physical quantity, they are connected to ADC (Analog to Digital Converter) to convert this analog information to digital format and then this digital information is processed using microcontroller.

The controlling section of this system is of great interest. The entire sensor's data are stored in the microcontroller memory and continuously monitored. If any of the sensors data exceeds or below its threshold level, it indicates the workers through a display device like PC in work place and through a GSM receiver in remote place which have connections to the microcontroller. Also we can automatically control the environment of Thermal Power Plant if any sensor level is high or low.

The level sensor is used to detect the level of water in the water tank. The level of water can be monitored by using microcontroller by sending the command to start motor 1. The levels of water are specified as low, mid, high. The temperature sensor is used to calculate the temp (T) inside the Boiler. In order to monitor that temperature, the command is send to the motor 2 through microcontroller.

The pressure sensor is used for the analysis of pressure of the steam inside the Boiler. When the pressures goes to high level then relay 1 is in OFF state and relay 2 is in the ON state. For low pressure, the exact opposite condition occurs. In any unavoidable situation, in the event of a fire in the room where the Boiler Plant is located then through a fire sensor and buzzer we can detect the situation. To minimize losses due to a fire, we use a buzzer to notify us in advance.

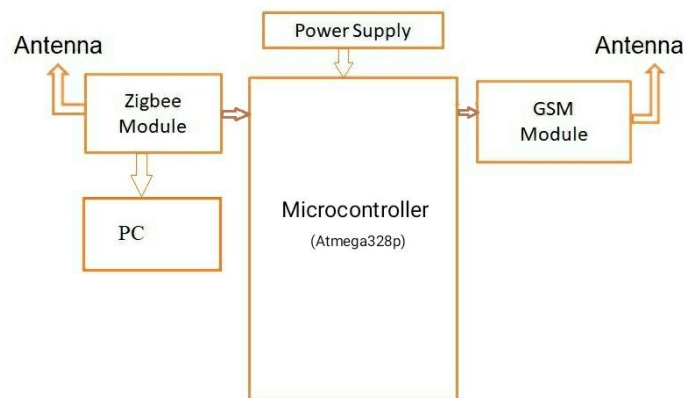

Figure 3.2: Receiver Block

On the receiving side, the Zigbee module is connected by telephone to the PC (Personal Computer). By using this PC the user can see the various target parameters of the Power Plant through the graphical interface. Zigbee is

connected to the data processing unit so that information from the transmission component is transmitted to a remote location so that an expert can be found in time to troubleshoot the problem

RESULT AND DISCUSSION

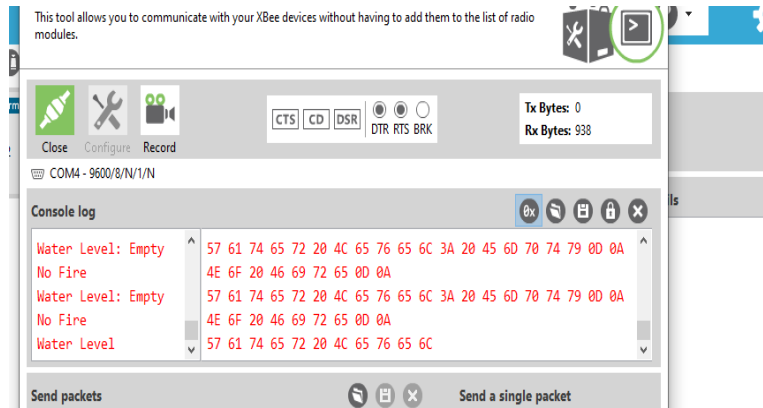

Figure 4.1

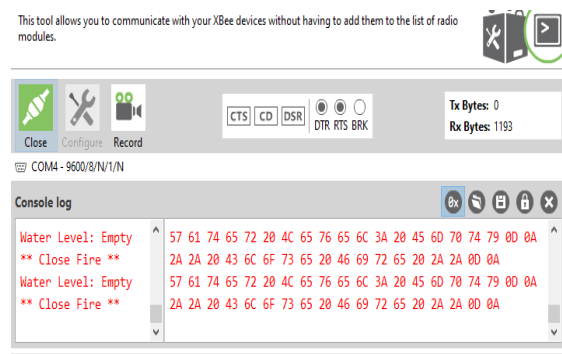

Figure 4.2

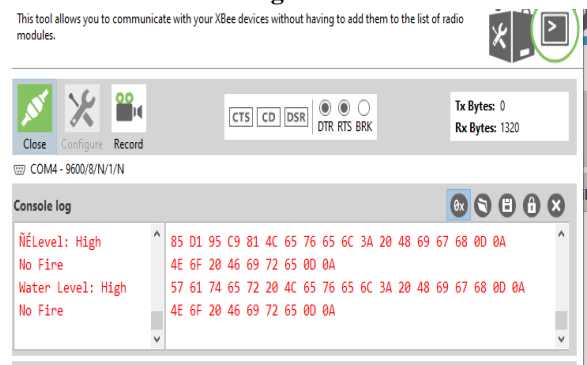

Figure 4.3

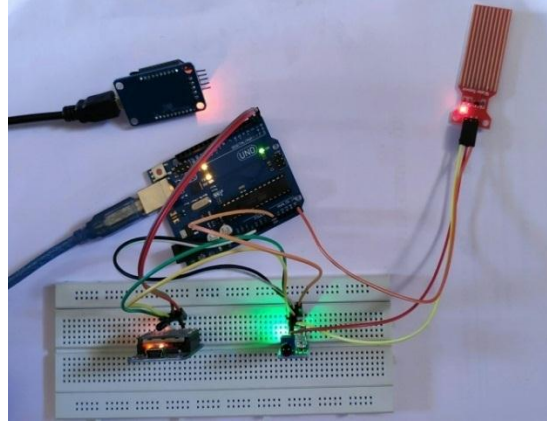

Figure 4.4

The Temperature, pressure, flame and Water level of Power Plant Boiler automation has designed and implemented in simulation as well as hardware. The result is shown in fig.4.1, 4.2 and 4.3 describes the Water level and detection of flame and also fig.4.4 shows the hardware

connection of our project. Sensing was done by sending every possible command to the Boiler and observed the Boiler's response. We also control the Boiler Power Plant by sending a control message.

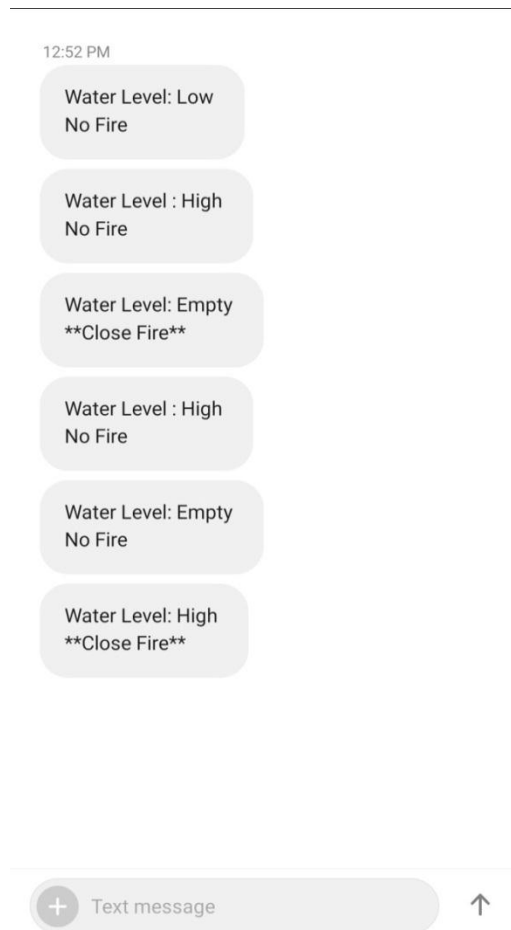

Figure 4.5

Boiler Automatic responded with serial port status in GSM and current boiler Water level and Flame. Fig.4.5 shows a message received by the Power Plant Boiler Operator Engineer when the Boiler Water level is high, low or empty and also detects the flame in the Boiler Power Plant. The controller of Arduino with GSM sent a warning message to the Boiler Operating Engineer with the current boiler Temperature, Pressure, Flame and Water level.

CONCLUSION

In this paper, monitoring and control system has been implemented for thermal Power Plant; By

using this system, monitoring and controlling of different parameters at the input side of Power Plant is possible. ZigBee technology is used for sending the information to the remote location. GSM sent a warning message to the Boiler operating engineer with the current Boiler temperature, water level and pressure level. The most important aspects of any Power Plant are the Boiler control. Several techniques can be implemented to control the Boiler in Power Plant. This method is to be used on various objectives like superior quality, increased efficiency, high profit and other points depending upon the purpose of Power Plant.

REFERENCES

- [1]. Daniel AlexandruVisan, IoanLita, Mariana Jurian and Ion BogdanCioc, "wireless measurement system based on zigbee transmission technology", 33rd International Spring Seminar on Electronics Technology, IEEE 2010, 978-1-4244-7850-7.
- [2]. Ganesh V. Padole, Sandip N. Kamble, "Embedded Wireless based Communication in Oilfield and Providing Security Syatem", International Journal Communication and Network Security (IJCNS), 1(2), 2011.
- [3]. Jagannath, V.M.D and B.Raman (2007). "WiBeam: Wireless Bearing Monitoring System" communication systems software and Middleware, COMSWARE 2007, 2nd International conference.
- [4]. C.Rojiha, "Sensor Network Based Automatic Control System for Oil Pumping Unit Management", International Journal of Scientific and Research Publications, 3(3), 2013.
- [5]. Chen, S. H., & Wang, C. P. The application of gray theory on wire cut electric discharge machine non-resistance sparkle circuit prediction. International Journal of Advanced Manufacturing Technology, 95(5-8), 2018, 2811-2820. <https://doi.org/10.1007/s00170-017-1317-7>
- [6]. P. Kundur Power system stability and control. New York: McGraw-Hill, 1994.
- [7]. Liu X J, Chai Ô Y, Liu Ç B. Fuzzy Logic Strategy forBoiler Control. ActaAutomaticaSinica, 24(4), 1998, 534-538.
- [8]. Maffezzoni C. Boiler-Turbine Dynamics in Power-PlantControl. Control Eng. Practice, 5(3), 1997, 301-312.
- [9]. R. Villalpando, D. Munoz-Rodriguez, C. Vargas-Rosales, and J. Rodriguez, "Position location in ad-hoc/sensor networks: a linear constrained search," *IEEE Commun. Lett.*, 15(6), 2011, 605–607.
- [10]. D. Flynn, *Thermal Power Plant Simulation and Control*. London, U.K.: The Institution of Engineering and Technology, 2003.
- [11]. A. Anto A. and Manivannan K., "A Power Quality Improved Bridgeless KY Converter Based Computer PowerSupply," *International Journal of MC Square Scientific Research (IJMSR)*, 9(1), 2017, 130-136.